

12091

FORD FUSION

GROSS LOAD CAPACITY WHEN USED AS A WEIGHT CARRYING HITCH: 3500 LBS. TRAILER WEIGHT & 350 LBS. TONGUE WEIGHT.

DO NOT EXCEED VEHICLE MANUFACTURER'S RECOMMENDED TOWING CAPACITY.

WARNING: ALL NON-TRAILER LOADS APPLIED TO THIS PRODUCT MUST BE SUPPORTED BY 18050 STABILIZING STRAPS.

** FAILURE TO PROPERLY SUPPORT NON-TRAILER LOADS WILL VOID PRODUCT WARRANTY**

Parts List			
ITE	QT	PART NUMBER	DESCRIPTION
1	4	HFN 1213, GR8	HEX FLANGE NUT
2	4	1/2-13 x 1 1/2, GR8	CARRIAGE BOLT
3	4	CM-SP10	.250 x 1.00 x 2.50" SQUARE HOLE SPACER
4	4	1_2 FISHWIRE	1/2" FISHWIRE

TOOLS REQUIRED
7mm & 10mm SOCKET
3/4" SOCKET
RATCHET
TORQUE WRENCH

FISHWIRE TECHNIQUE

INSERT COILED END OF FISHWIRE TOOL THROUGH HITCH MOUNTING HOLE IN VEHICLE FRAME RAIL AND OUT THE ACCESS HOLE. PASS COILED END OF FISHWIRE THROUGH SPACER AND THREAD BOLT INTO COIL. KINK WIRE TO KEEP SPACER SEPERATE FROM BOLT AS SHOWN. PULL FISHWIRE, SPACER, AND BOLT THROUGH FRAME AND OUT MOUNTING HOLE. USE FISHWIRE TO GUIDE HITCH DURING MOUNTING AND PREVENT LOSS OF BOLT / SPACER INSIDE FRAME RAIL.

NOTE: SOME VEHICLES MAY FISHWIRE THROUGH END OF FRAME

FRONT
↓
REAR

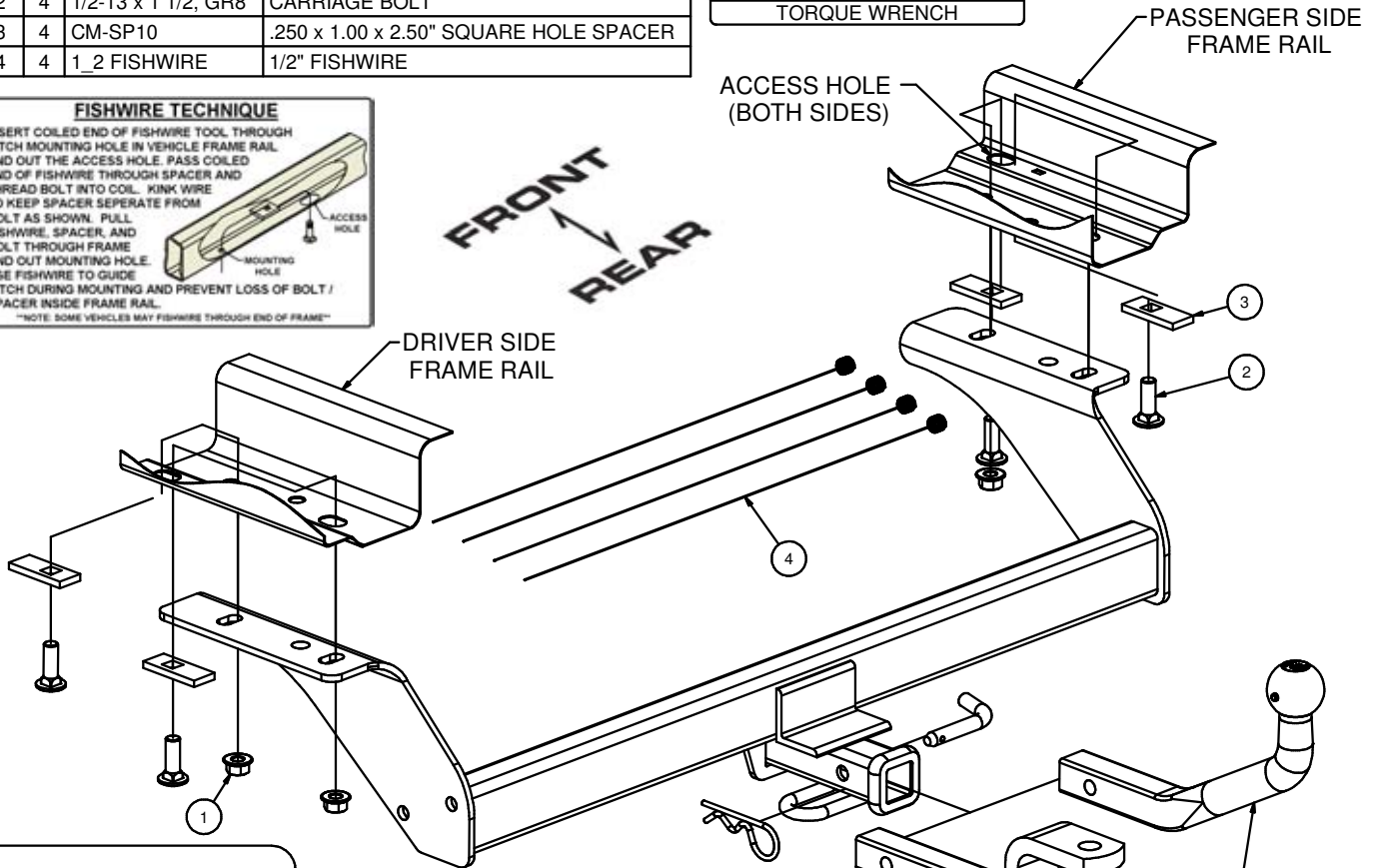

OPTIONAL BALL MOUNT #D-224/45016

DESIGNED FOR USE WITH EURO MOUNT #45562 (2" BALL) & 45561 (1 7/8" BALL)

HITCH WEIGHT: 26 LBS.
 INSTALL TIME
 PROFESSIONAL: 20 MINUTES
 NOVICE (DIY): 40 MINUTES
 INSTALL NOTES:
 -REMOVE BODY PART
 -FISHWIREING REQ.
 -NO DRILL REQ.

INSTALLATION STEPS

1. Remove (4) 10mm nuts and (6) 7mm screws from the lower body fascia.
2. Remove lower body fascia. Return fascia piece and hardware to customer.
3. Fishwire the 1/2" bolt and spacer blocks though the access hole in both sides for the frame.
4. Raise hitch into position and secure with 1/2" flange nuts.
5. Torque all 1/2" hardware to 110 lb-ft.

PERIODICALLY CHECK THIS RECEIVER HITCH TO ENSURE THAT ALL FASTENERS ARE TIGHT AND THAT ALL STRUCTURAL COMPONENTS ARE SOUND.



Safety glasses should be worn at all times while installing this product.

YEARS: 2013-PRESENT

MAKE: FORD

MODEL: FUSION

STYLE: SEDAN

WARNING: NEVER EXCEED YOUR VEHICLE MANUFACTURER'S RECOMMENDED TOWING CAPACITY

WEIGHT CARRYING:
 TRAILER WEIGHT: 3500 LBS.
 TONGUE WEIGHT: 350 LBS.

INSTALLATION TIME: 20/40 MIN.

THE INSTALL TIME LISTED IS FOR PROFESSIONAL /NOVICE INSTALLERS. IF YOU ARE HESITANT TO UNDERTAKE THIS TASK ON YOUR OWN, CONTACT AN AUTHORIZED CURT INSTALLER FOR ADDITIONAL ASSISTANCE.



INSTALLATION REQUIRES:

 RATCHET	 TORQUE WRENCH	 10mm 7mm 3/4" SOCKET
 SAFETY GLASSES		

INSTALLATION TIPS:

- BEFORE YOU BEGIN INSTALLATION, READ ALL INSTRUCTIONS THOROUGHLY.
- TO EASE INSTALLATION, 2 PEOPLE MAY BE REQUIRED.
- USING PROPER TOOLS WILL GREATLY IMPROVE THE QUALITY OF THE INSTALL AND REDUCE THE TIME REQUIRED.

LEVEL OF DIFFICULTY: EASY

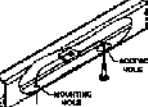
<i>EASY</i>	<i>MODERATE</i>	<i>CHALLENGING</i>
	NO DRILLING REQUIRED	
	REMOVE LOWER REAR AIR DEFLECTOR	
	FISHWIRING REQUIRED	

VEHICLE PHOTO:

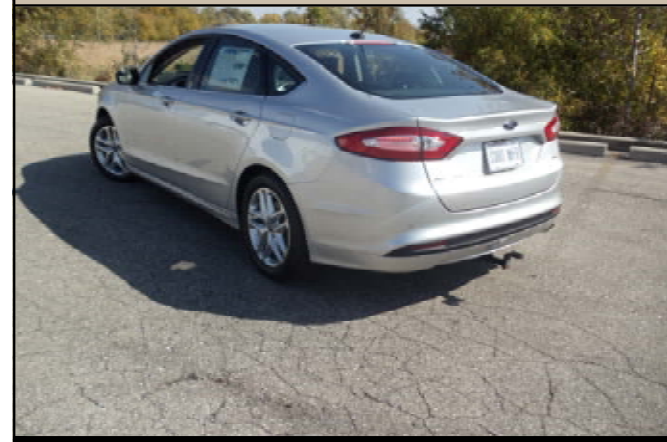

REPRESENTATIVE PHOTO

HITCH ILLUSTRATION:

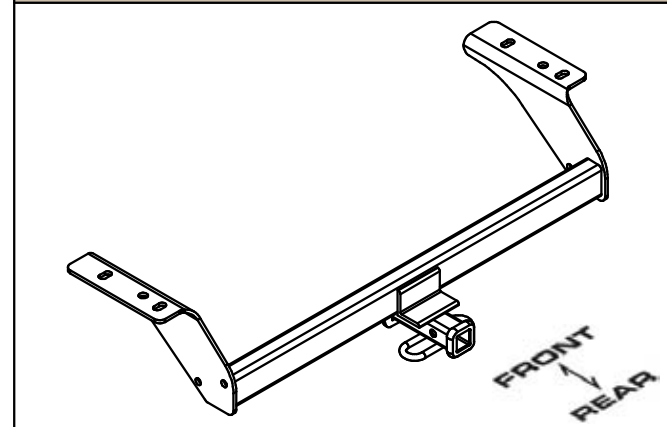

MAKE SURE YOUR HITCH MATCHES

PERIODICALLY CHECK THIS RECEIVER HITCH TO ENSURE ALL FASTENERS ARE TIGHT AND ALL STRUCTURAL COMPONENTS ARE SOUND

CURT Manufacturing LLC. warrants this product to be free of defects in material and/or workmanship at the time of retail purchase by the original purchaser. If the product is found to be defective, Curt Manufacturing LLC. may repair or replace the product at their option, when the product is returned, prepaid, with proof of purchase. Alteration to, misuse of, or improper installation of this product voids the warranty. Curt Manufacturing LLC.'s liability is limited to repair or replacement of products found to be defective, and specifically excludes liability for incidental or consequential loss or damage.

INSTALLATION WALKTHROUGH:

Parts List			
ITEM	QTY	PART NUMBER	DESCRIPTION
1	4	HFN 1213, GR8	HEX FLANGE NUT
2	4	1/2-13 x 1 1/2, GR8	CARRIAGE BOLT
3	4	CM-SP10	.250 x 1.00 x 2.50" SPACER
4	4	1_2 FISHWIRE	1/2" FISHWIRE

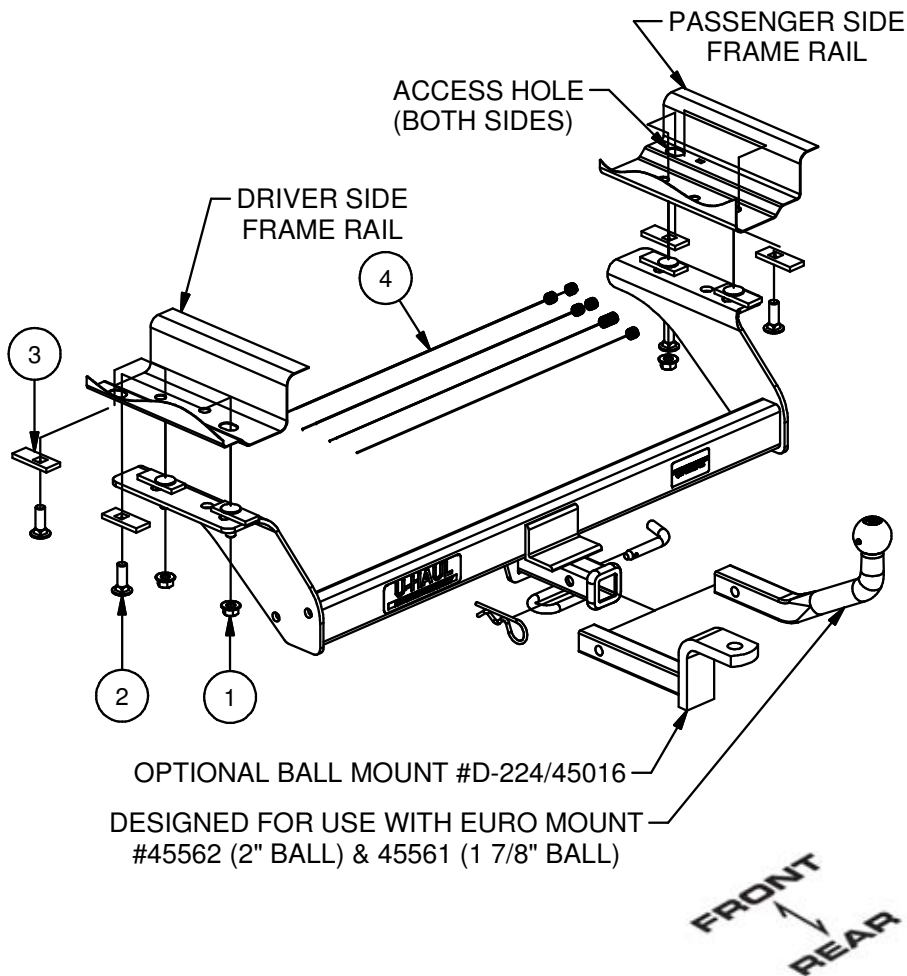

1. Remove (4) 10mm nuts and (6) 7mm screws from the lower body fascia.

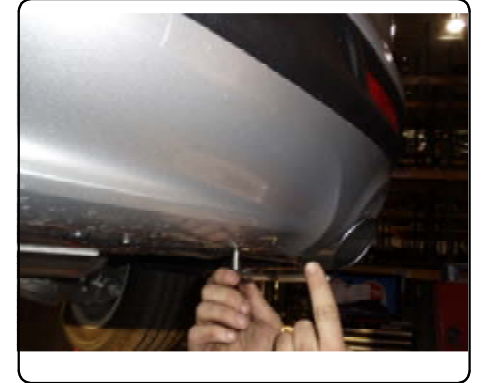
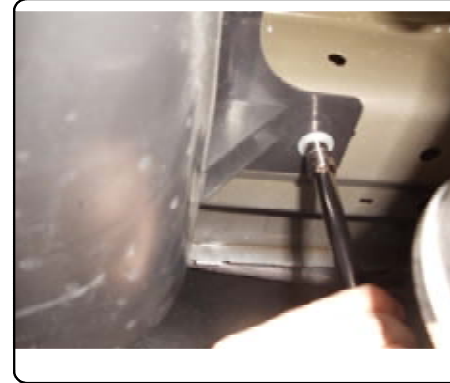

2. Remove lower body fascia. Return fascia piece and hardware to customer.

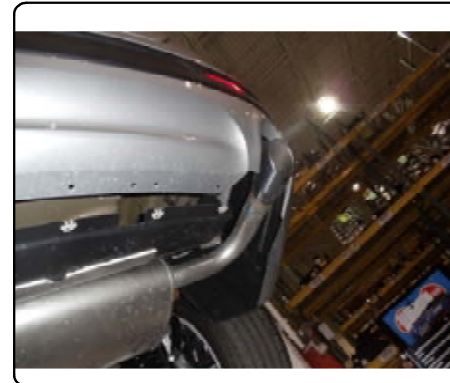

INSTALLATION WALKTHROUGH:

3. Fishwire the 1/2" bolts and spacer blocks through the access hole each side of the vehicle frame rail, as shown.



4. Raise hitch into position and secure with 1/2" flange nuts.

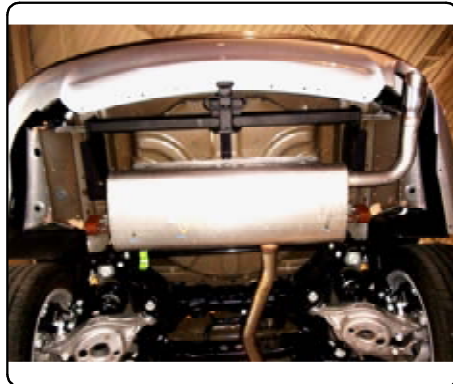

5. Torque all 1/2" hardware to 110 lb-ft.

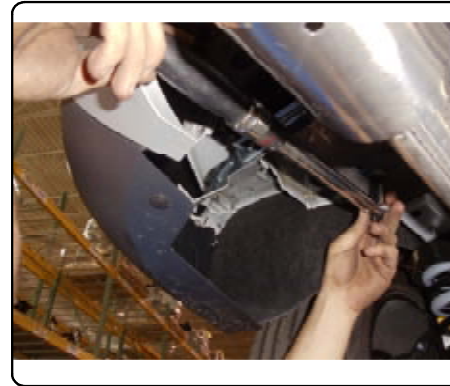

6. Installation complete.

