

GROSS LOAD CAPACITY WHEN USED AS A WEIGHT CARRYING HITCH: 3,500 LBS. TRAILER WEIGHT & 350 LBS. TONGUE WEIGHT.

\*\*\*DO NOT EXCEED VEHICLE MANUFACTURER'S RECOMMENDED TOWING CAPACITY.\*\*\*

WARNING: ALL NON-TRAILER LOADS APPLIED TO THIS PRODUCT MUST BE SUPPORTED BY 18050 STABILIZING STRAPS.

\*\* FAILURE TO PROPERLY SUPPORT NON-TRAILER LOADS WILL VOID PRODUCT WARRANTY\*\*

Parts List			
ITEM	QTY	PART NUMBER	DESCRIPTION
1	6	M12 - 1.25 x 40 HEX	HEX BOLT
2	6	1/2"	CONICAL TOOTHED WASHER

TOOLS REQUIRED
RATCHET
TORQUE WRENCH
6" EXTENSION
19mm SOCKET
SCREWDRIVER
AVIATION SHEARS

#### RUBBER ISOLATOR REMOVAL DIAGRAM

This technique can be used if an Exhaust Hanger Removal Pliers is not available.

Using a 5/8" open end wrench, slide the wrench up to the rubber isolator, cradling the hanger rod as shown. Next place the flat edge of a pry bar between the wrench and the hanger stop or hanger rod. Then simply rotate the pry bar toward the wrench to remove the rubber isolator.

Note: Using a spray lubricant or soapy water on the hanger rod and the rubber isolator helps removal.

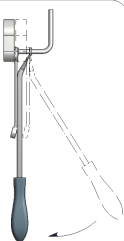

#### WELDNUT CLEANING

To remove debris from weldnuts in frame, spray lubricant or compressed air into hole. For heavy debris, use a small wire brush. (Be careful not to damage threads).

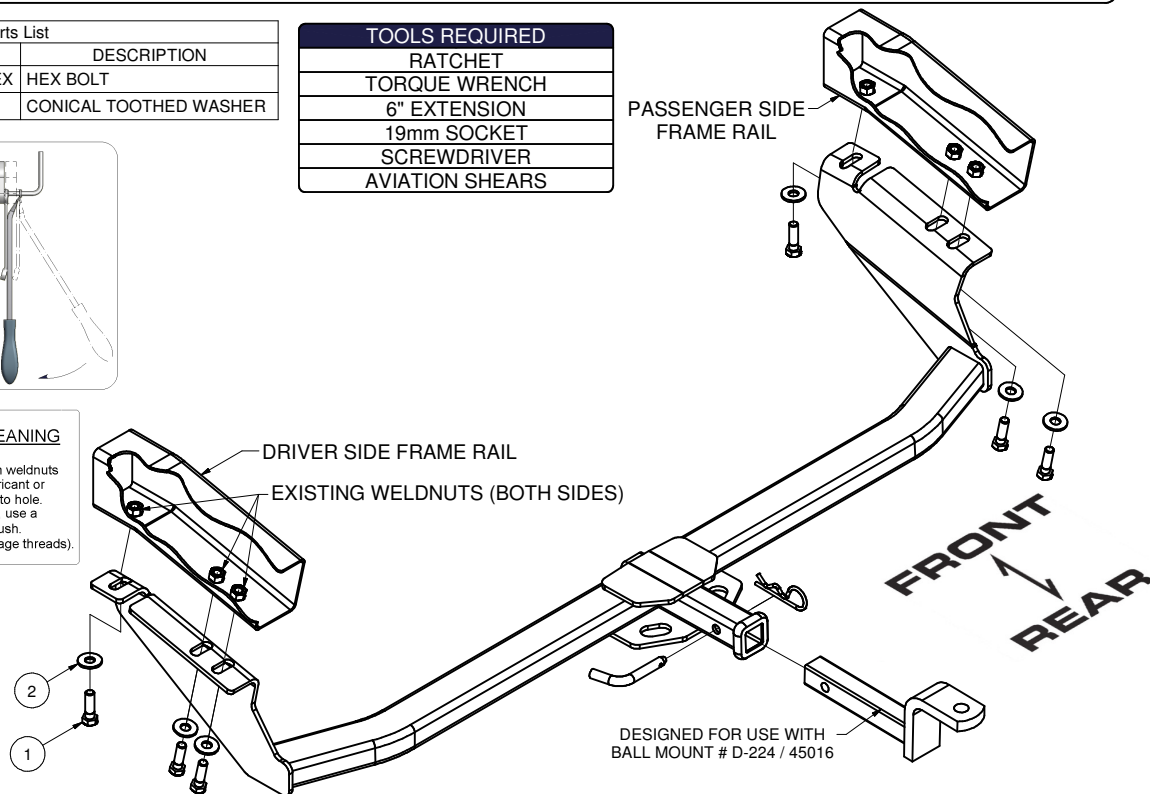
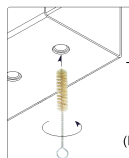

HITCH WEIGHT: 33 LBS.

#### INSTALL TIME

PROFESSIONAL: 25 MINUTES

NOVICE (DIY): 50 MINUTES

#### INSTALL NOTES:

- NO DRILLING REQUIRED
- MAY REQUIRE TRIMMING IF UNDERBODY PANEL IS PRESENT

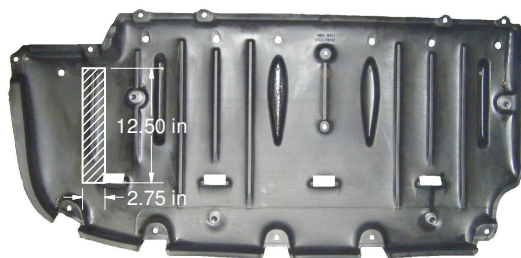

UNDERBODY TRIM DIAGRAM 1



UNDERBODY TRIM DIAGRAM 2

## INSTALLATION STEPS

1. Remove underbody panel, if present.
2. Lower exhaust assembly for ease of installation. (SEE RUBBER ISOLATOR REMOVAL DIAGRAM)
3. Remove hole plugs in frame rails and clean weldnuts. (SEE WELDNUT CLEANING DIAGRAM)
4. Mark underbody panel for trimming, confirm fit prior to trimming. (See Underbody Trim Diagram 1) **Note:** Some models may have a lip that protrudes down, if present this will need to be trimmed as well. (See Underbody Trim Diagram 2)
5. Slide driver side plate through slot trimmed in underbody panel. Raise hitch and underbody panel into position aligning holes with existing weldnuts. **Note:** Underbody panel will be sandwiched between the hitch and the trunk pan.
6. Secure hitch with M12 hex bolts and conical toothed washers as shown.
7. Torque all M12 fasteners to 64 ft-lbs.
8. Reattach underbody panel.
9. Raise exhaust.

**PERIODICALLY CHECK THIS RECEIVER HITCH TO ENSURE THAT ALL FASTENERS ARE TIGHT AND THAT ALL STRUCTURAL COMPONENTS ARE SOUND.**

Curt Manufacturing Inc., warrants this product to be free of defects in material and/or workmanship at the time of retail purchase by the original purchaser. If the product is found to be defective, Curt Manufacturing Inc., may repair or replace the product, at their option, when the product is returned, prepaid, with proof of purchase. Alteration to, misuse of, or improper installation of this product voids the warranty. Curt Manufacturing Inc.'s liability is limited to repair or replacement of products found to be defective, and specifically excludes liability for incidental or consequential loss or damage.