



12022 INSTALLATION INSTRUCTIONS



Safety glasses should be worn at all times while installing this product.

YEARS: 2010-PRESENT

MAKE: BUICK

MODEL: LUCERNE

STYLE: SEDAN





WARNING: NEVER EXCEED YOUR VEHICLE MANUFACTURER'S RECOMMENDED TOWING CAPACITY

WEIGHT CARRYING:
TRAILER WEIGHT: 3,500 LBS.
TONGUE WEIGHT: 350 LBS.

INSTALLATION TIME: 30 MIN.

THE INSTALL TIME LISTED IS FOR PROFESSIONAL INSTALLERS. IF YOU ARE HESITANT TO UNDERTAKE THIS TASK ON YOUR OWN, CONTACT AN AUTHORIZED CURT INSTALLER FOR ADDITIONAL ASSISTANCE.



INSTALLATION REQUIRES:

 RATCHET	 TORQUE WRENCH	 10" SOCKET EXTENSION
 15mm 17mm 3/4" SOCKET	 SPRAY LUBRICANT	 SAFETY GLASSES

INSTALLATION TIPS:

- BEFORE YOU BEGIN INSTALLATION, READ ALL INSTRUCTIONS THOROUGHLY.
- TO EASE INSTALLATION, 2 PEOPLE MAY BE REQUIRED.
- USING PROPER TOOLS WILL GREATLY IMPROVE THE QUALITY OF THE INSTALL AND REDUCE THE TIME REQUIRED.

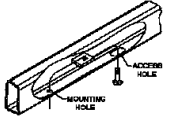
LEVEL OF DIFFICULTY: MODERATE

EASY	MODERATE	HARD
	- NO DRILLING REQUIRED	
	- FISHWIRE HARDWARE	
	- LOWER EXHAUST	
	- WELDNUT CLEANING	

VEHICLE PHOTO:



REPRESENTATIVE PHOTO

HITCH ILLUSTRATION:

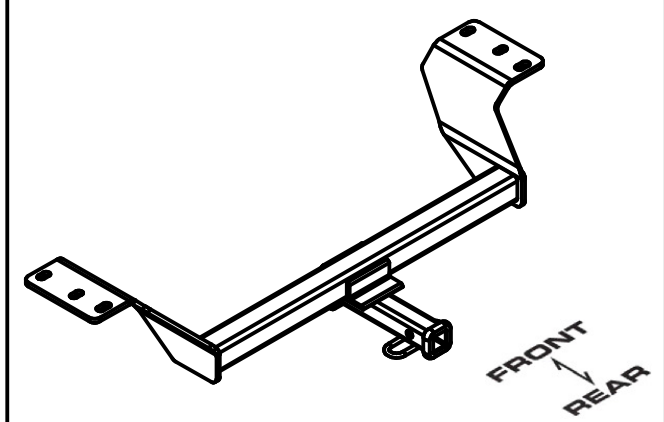

MAKE SURE YOUR HITCH MATCHES

PERIODICALLY CHECK THIS RECEIVER HITCH TO ENSURE ALL FASTENERS ARE TIGHT AND ALL STRUCTURAL COMPONENTS ARE SOUND

CURT Manufacturing Inc. warrants this product to be free of defects in material and/or workmanship at the time of retail purchase by the original purchaser. If the product is found to be defective, Curt Manufacturing Inc. may repair or replace the product at their option, when the product is returned, prepaid, with proof of purchase. Alteration to, misuse of, or improper installation of this product voids the warranty. Curt Manufacturing Inc.'s liability is limited to repair or replacement of products found to be defective, and specifically excludes liability for incidental or consequential loss or damage.

INSTALLATION WALKTHROUGH:

Parts List			
ITEM	QTY	PART NUMBER	DESCRIPTION
1	2	3/8"	CONICAL TOOTHED WASHER
2	2	M10 - 1.5 x 40mm	HEX BOLT
3	4	HFN 1213	HEX FLANGE NUT
4	4	CM-SP6	.250 x 1.00 x 3.00" SQUARE HOLE SPACER
5	4	1/2-13 x 1 1/4	CARRIAGE BOLT
6	2	1_2 FISHWIRE	1/2" FISHWIRE

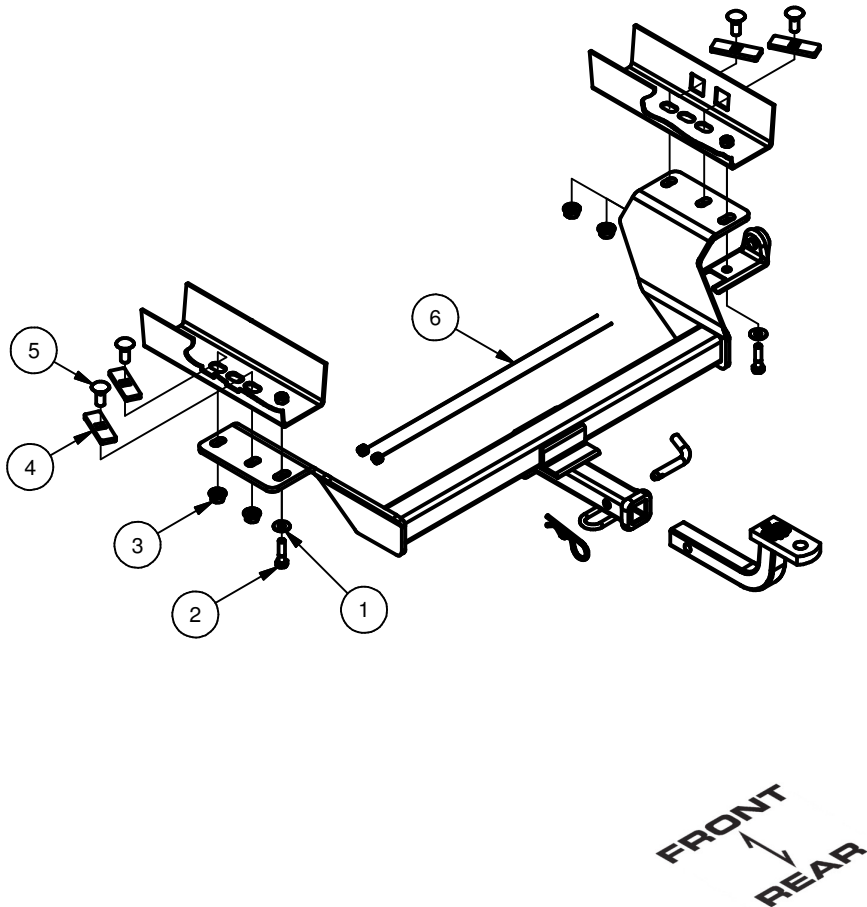

1. Lower exhaust for ease of installation.

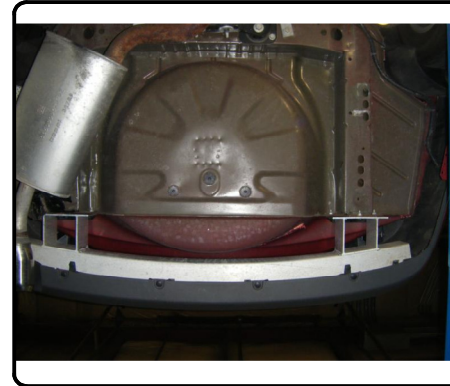

RUBBER ISOLATOR REMOVAL DIAGRAM

This technique can be used if an Exhaust Hanger Removal Pliers is not available.

Using a 5/8" open end wrench, slide the wrench up to the rubber isolator, cradling the hanger rod as shown. Next place the flat edge of a pry bar between the wrench and the hanger stop or hanger rod. Then simply rotate the pry bar toward the wrench to remove the rubber isolator.

Note: Using a spray lubricant or soapy water on the hanger rod and the rubber isolator helps removal.

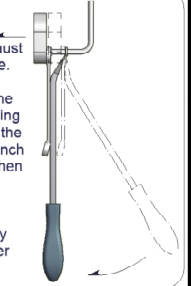

2. Remove the exhaust hanger bracket from the bottom of the frame rail, retain bracket for later use. **Note:** If equipped with dual exhaust remove both exhaust brackets.



INSTALLATION WALKTHROUGH:

3. Fishwire 1/2-13 x 1 1/4" carriage bolts and SP6 spacers through access holes, 2 each side.

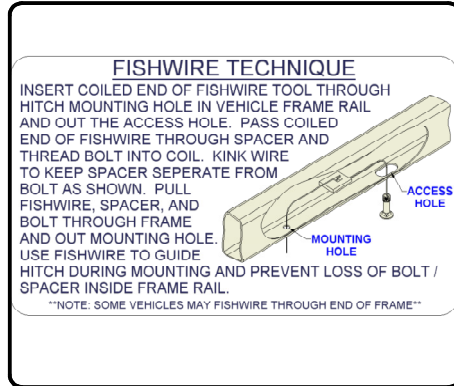

4. Raise hitch into position and loosely secure with 1/2" flange nuts.



5. Reinstall factory exhaust hanger bracket. Secure using M10-1.5 x 40mm bolts and 3/8" conical toothed washers into existing weldnuts. **Note:** On exhaust side(s) hitch will be sandwiched between the frame rail and exhaust bracket.

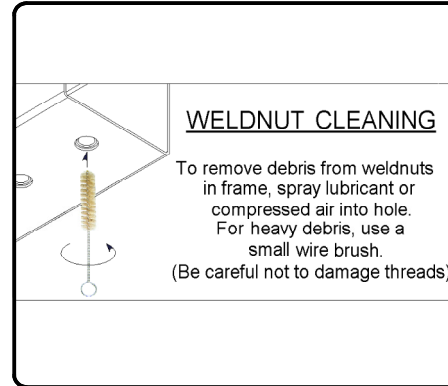

6. Torque all 1/2" hardware to 75 ft-lbs. Torque all M10 hardware to 35 ft-lbs. Raise exhaust back into position.



12022

BUICK LUCERNE CX, CXL, & CXL PREMIUM

GROSS LOAD CAPACITY WHEN USED AS A WEIGHT CARRYING HITCH: 3,500 LBS. TRAILER WEIGHT & 350 LBS. TONGUE WEIGHT.

DO NOT EXCEED VEHICLE MANUFACTURER'S RECOMMENDED TOWING CAPACITY.

WARNING: ALL NON-TRAILER LOADS APPLIED TO THIS PRODUCT MUST BE SUPPORTED BY 18050 STABILIZING STRAPS.

** FAILURE TO PROPERLY SUPPORT NON-TRAILER LOADS WILL VOID PRODUCT WARRANTY**

Parts List			
ITEM	QTY	PART NUMBER	DESCRIPTION
1	2	3/8"	CONICAL TOOTHED WASHER
2	2	M10 - 1.5 x 40mm	HEX BOLT
3	4	HFN 1213	HEX FLANGE NUT
4	4	CM-SP6	.250 x 1.00 x 3.00" SQUARE HOLE SPACER
5	4	1/2-13 x 1 1/4	CARRIAGE BOLT
6	2	1_2 FISHWIRE	1/2" FISHWIRE

RATCHET
TORQUE WRENCH
10" EXTENSION
15mm SOCKET
17mm SOCKET
3/4" SOCKET

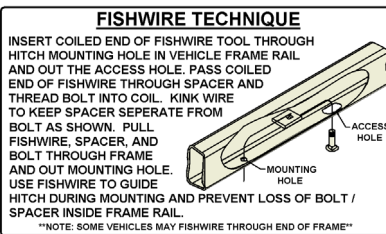
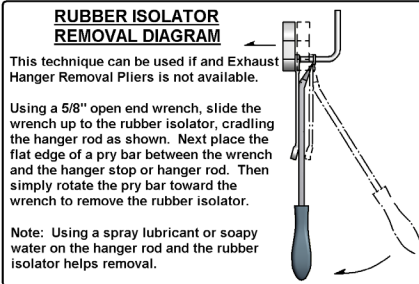
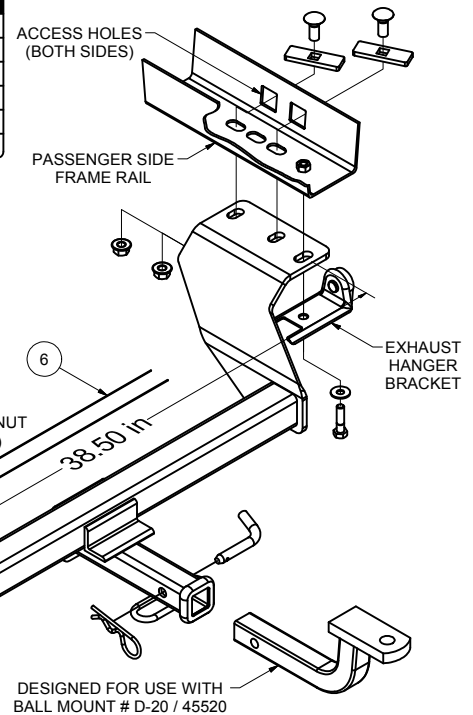

HITCH WEIGHT: 36 LBS.

INSTALL TIME

PROFESSIONAL: 30 MINUTES

NOVICE (DIY): 60 MINUTES

INSTALL NOTES:

- NO DRILLING REQUIRED
- FISHWIRE HARDWARE
- LOWER EXHAUST

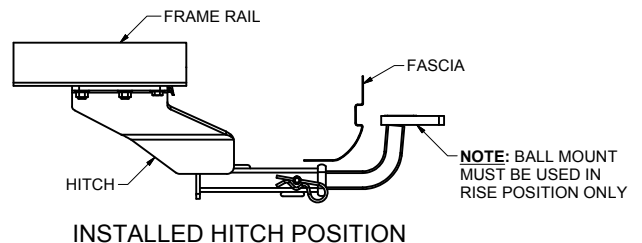
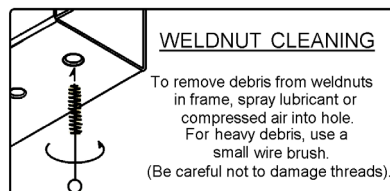

INSTALLATION STEPS

1. Lower exhaust for ease of installation. (See Rubber Isolator Remove Diagram)
2. Remove the exhaust hanger bracket from the bottom of the frame rail, retain bracket for later use. **Note:** If equipped with dual exhaust remove two exhaust brackets.
3. Fishwire 1/2-13 x 1 1/4" carriage bolts and SP6 spacers through access holes, as shown. (See Fishwire Technique Diagram)
4. Raise hitch into position and loosely secure with 1/2" flange nuts to the bolts fishwired in Step 4.
5. Reinstall factory exhaust hanger bracket. Secure using M10-1.5 x 40mm bolts and 3/8" conical toothed washers into existing weldnuts, as shown. (See Weldnut Cleaning Diagram) **Note:** On exhaust side(s) hitch will be sandwiched between the frame rail and exhaust bracket.
6. Torque all 1/2" hardware to 75 ft-lbs. Torque all M10 hardware to 35 ft-lbs.
7. Raise exhaust back into position.

PERIODICALLY CHECK THIS RECEIVER HITCH TO ENSURE THAT ALL FASTENERS ARE TIGHT AND THAT ALL STRUCTURAL COMPONENTS ARE SOUND.

Curt Manufacturing Inc., warrants this product to be free of defects in material and/or workmanship at the time of retail purchase by the original purchaser. If the product is found to be defective, Curt Manufacturing Inc., may repair or replace the product, at their option, when the product is returned, prepaid, with proof of purchase. Alteration to, misuse of, or improper installation of this product voids the warranty. Curt Manufacturing Inc.'s liability is limited to repair or replacement of products found to be defective, and specifically excludes liability for incidental or consequential loss or damage.