

11664

86-93 VOLVO 140, 160, 240 SERIES

GROSS LOAD CAPACITY WHEN USED AS A WEIGHT CARRYING HITCH: 1,500 LBS. TRAILER WEIGHT & 150 LBS. TONGUE WEIGHT.

DO NOT EXCEED VEHICLE MANUFACTURER'S RECOMMENDED TOWING CAPACITY.

WARNING: ALL NON-TRAILER LOADS APPLIED TO THIS PRODUCT MUST BE SUPPORTED BY 18050 STABILIZING STRAPS.

** FAILURE TO PROPERLY SUPPORT NON-TRAILER LOADS WILL VOID PRODUCT WARRANTY**

Parts List			
ITEM	QTY	PART NUMBER	DESCRIPTION
1	6	3/8 - 16 x 1 1/4	HEX BOLT
2	4	3/8"	FENDER WASHER
3	6	3/8"	LOCK WASHER
4	6	3/8 - 16	HEX NUT
5	2	3/8"	WASHER

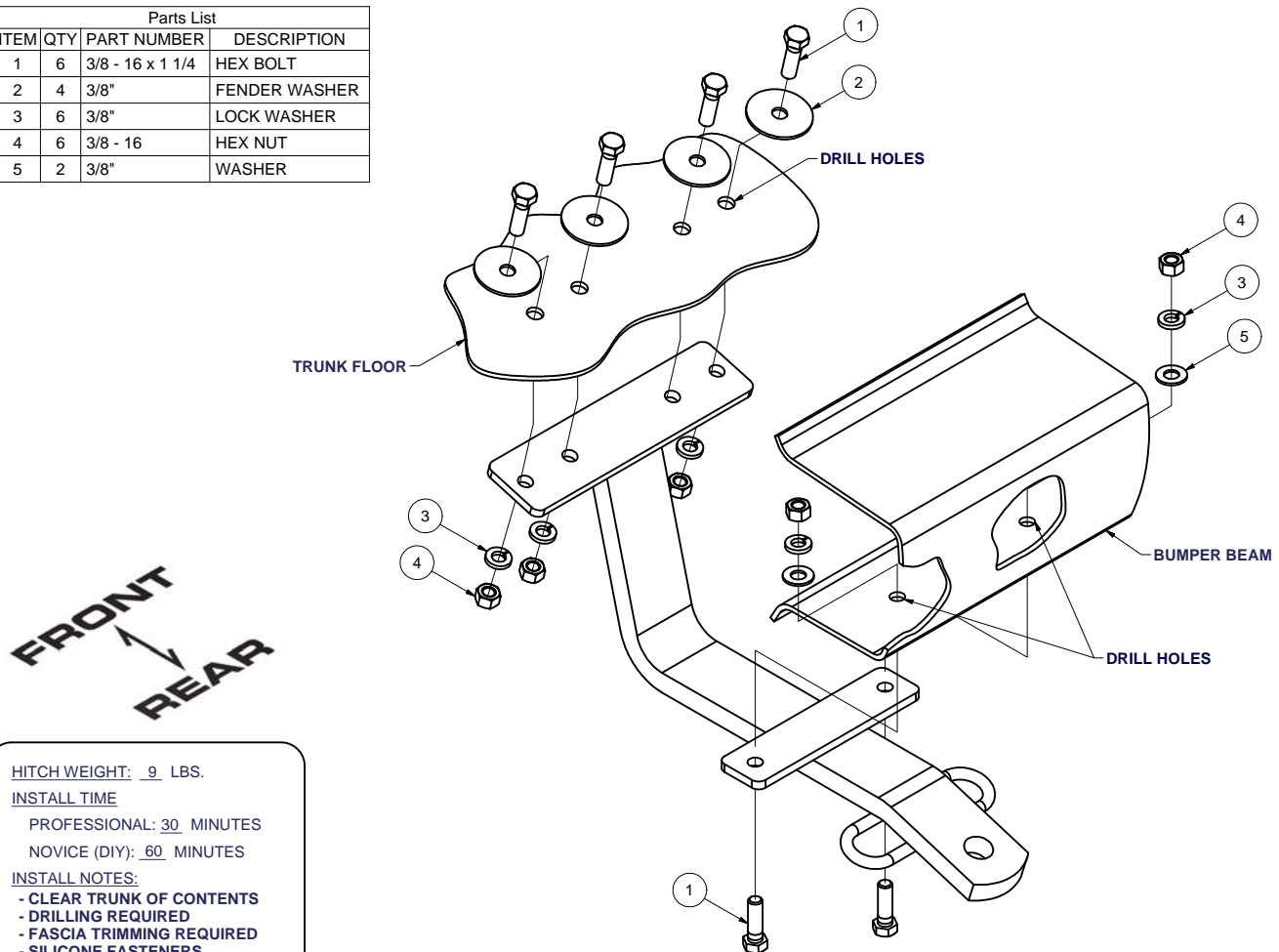

HITCH WEIGHT: 9 LBS.

INSTALL TIME

PROFESSIONAL: 30 MINUTES

NOVICE (DIY): 60 MINUTES

INSTALL NOTES:

- CLEAR TRUNK OF CONTENTS
- DRILLING REQUIRED
- FASCIA TRIMMING REQUIRED
- SILICONE FASTENERS

INSTALLATION STEPS

1. Clear contents out of the trunk for drilling. Position the hitch against the underside of the trunk floor and bumper, centered and square with the vehicle. Check for enough hitch ball/bumper clearance.
2. Remove any plastic/rubber covering at the bottom of the rear bumper where the hitch bracket makes contact. The hitch must seat directly against the metal bumper.
3. Using the hitch as a template to mark and drill (4) places in trunk floor, and (2) places in the bottom of the bumper beam. All holes are for 3/8" diameter bolts.
4. Bolt the hitch to the floor panel and bumper beam using fasteners as shown. Make sure to install fender washers opposite the hitch inside the trunk.
5. Torque all 3/8" fasteners to 30 lb-ft.
6. Use silicone caulk to seal around fasteners in trunk pan to seal out water and exhaust vapors.
7. Replace contents of trunk removed in step 1.

PERIODICALLY CHECK THIS RECEIVER HITCH TO ENSURE THAT ALL FASTENERS ARE TIGHT AND THAT ALL STRUCTURAL COMPONENTS ARE SOUND.

Curt Manufacturing Inc., warrants this product to be free of defects in material and/or workmanship at the time of retail purchase by the original purchaser. If the product is found to be defective, Curt Manufacturing Inc., may repair or replace the product, at their option, when the product is returned, prepaid, with proof of purchase. Alteration to, misuse of, or improper installation of this product voids the warranty. Curt Manufacturing Inc.'s liability is limited to repair or replacement of products found to be defective, and specifically excludes liability for incidental or consequential loss or damage.

Looking for dependable trailer hitches and towing? Rely on CURT for quality and long-lasting products.