

1164979-83 TOYOTA COROLLA, 79-83 CORONA, 81-84 STARLET HATCHBACK,
83-86 TERCEL HATCHBACK & WAGON (INCLUDING 4WD)**GROSS LOAD CAPACITY WHEN USED AS A WEIGHT CARRYING HITCH: 1,000 LBS. TRAILER WEIGHT & 100 LBS. TONGUE WEIGHT.**

DO NOT EXCEED VEHICLE MANUFACTURER'S RECOMMENDED TOWING CAPACITY.

WARNING: ALL NON-TRAILER LOADS APPLIED TO THIS PRODUCT MUST BE SUPPORTED BY 18050 STABILIZING STRAPS.

** FAILURE TO PROPERLY SUPPORT NON-TRAILER LOADS WILL VOID PRODUCT WARRANTY**

Parts List					
ITEM	QTY	PART NUMBER	DESCRIPTION		
1	1	1/2-13	HANDLE NUT		
2	1	1/2-13 x 1 3/4	HEX BOLT		
3	2	7/16 - 14 x 1 3/4	CARRIAGE BOLT		
4	2	7/16-14	HEX FLANGE NUT		
5	2	CM-SP2	.250 x .88 x 2.25" SQUARE HOLE SPACER		
6	2	7_16 FISHWIRE	7/16" FISHWIRE		

FISHWIRE TECHNIQUE

INSERT COILED END OF FISHWIRE TOOL THROUGH HITCH MOUNTING HOLE IN VEHICLE FRAME RAIL AND OUT THE ACCESS HOLE. PASS COILED END OF FISHWIRE THROUGH SPACER AND THREAD BOLT INTO COIL. KINK WIRE TO KEEP SPACER SEPARATE FROM BOLT AS SHOWN. PULL FISHWIRE, SPACER, AND BOLT THROUGH FRAME AND OUT MOUNTING HOLE. USE FISHWIRE TO GUIDE HITCH DURING MOUNTING AND PREVENT LOSS OF BOLT / SPACER INSIDE FRAME RAIL.

NOTE: SOME VEHICLES MAY FISHWIRE THROUGH END OF FRAME

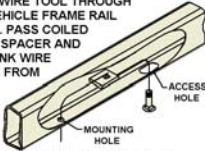

FRONT
↑
REAR

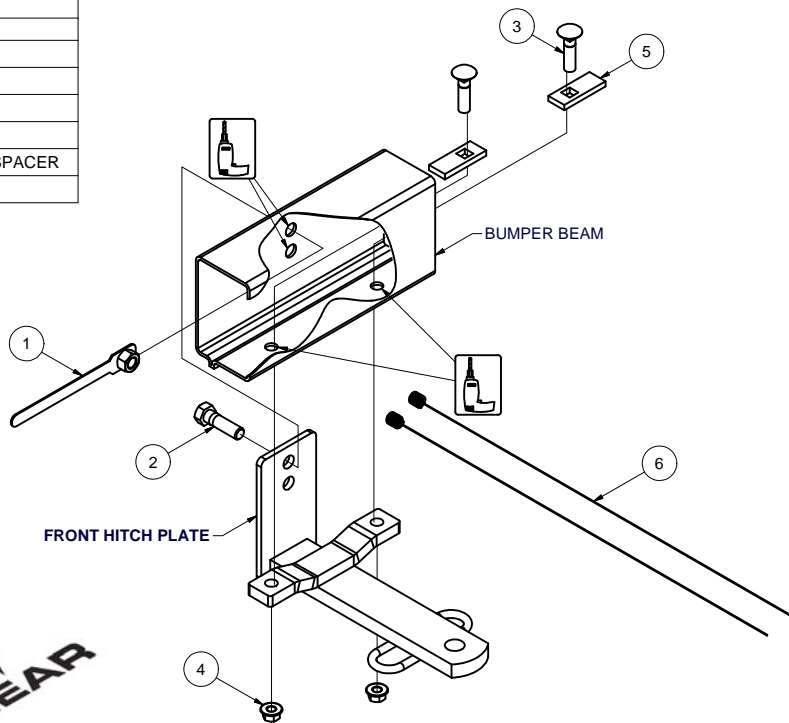

HITCH WEIGHT: 7 LBS.

INSTALL TIME

PROFESSIONAL: 45 MINUTES

NOVICE (DIY): 90 MINUTES

INSTALL NOTES:

- TEMP. REMOVE BUMPER
- TRIM U-CHANNEL
- TRIM RUBBER FASCIA
- DRILLING REQUIRED
- FISHWIRE HARDWARE

INSTALLATION STEPS

1. Remove the rear bumper by removing 4 to 6 screws located under the rubber covers inside the trunk/hatch area, or under the vehicle near the bumper ends. Also remove small screws located at the ends of the bumper in the fender. Save hardware and bumper for reinstallation.
2. Locate and mark the vehicle's centerline on the metal u-channel that retains the rubber fascia at the bottom of the bumper. An 8" section (4" each side of center) of the channel must be cut away. Also cut away an 8" length of the rubber fascia so the hitch bumper bracket will mate directly to the steel bumper. Replace the remaining parts of the u-channel.
3. Place the hitch as shown centered on the steel bumper. Using the hitch bumper bracket as a template, drill holes in bumper 1/2" diameter. If enlarging existing holes, it may help to remove existing weldnuts inside the bumper beam with a hammer and drift pin or bolt.
4. Place 7/16" carriage bolts and CM-SP2 spacers through holes just drilled from the INSIDE of the bumper. Fishwire fasteners into place if necessary. An access hole may need to be drilled in some bumpers. Carefully position the hitch over the bolts and fasten with hex flange nuts as shown.
5. Drill bumper using best hole in front hitch plate for 1/2" fasteners. Existing holes may match some models. Ignore the extra hole in the plate. Fasten hitch using handle nut from INSIDE the bumper. Handle should fit through adjacent hole and be flattened against the bumper after final tightening.
6. Torque all 7/16" fasteners to 50 lb-ft, and all 1/2" fasteners to 75 lb-ft.
7. Reinstall bumper in reverse order from Step 1.

PERIODICALLY CHECK THIS RECEIVER HITCH TO ENSURE THAT ALL FASTENERS ARE TIGHT AND THAT ALL STRUCTURAL COMPONENTS ARE SOUND.

Curt Manufacturing Inc., warrants this product to be free of defects in material and/or workmanship at the time of retail purchase by the original purchaser. If the product is found to be defective, Curt Manufacturing Inc., may repair or replace the product, at their option, when the product is returned, prepaid, with proof of purchase. Alteration to, misuse of, or improper installation of this product voids the warranty. Curt Manufacturing Inc.'s liability is limited to repair or replacement of products found to be defective, and specifically excludes liability for incidental or consequential loss or damage.

Looking for dependable trailer hitches and towing? Rely on CURT for quality and long-lasting products.