

11629

## 89-94 SUBARU JUSTY 2 AND 4 WD

**GROSS LOAD CAPACITY WHEN USED AS A WEIGHT CARRYING HITCH: 1,000 LBS. TRAILER WEIGHT & 100 LBS. TONGUE WEIGHT.**

\*\*\*DO NOT EXCEED VEHICLE MANUFACTURER'S RECOMMENDED TOWING CAPACITY.\*\*\*

**WARNING: ALL NON-TRAILER LOADS APPLIED TO THIS PRODUCT MUST BE SUPPORTED BY 18050 STABILIZING STRAPS.**

\*\* FAILURE TO PROPERLY SUPPORT NON-TRAILER LOADS WILL VOID PRODUCT WARRANTY\*\*

Parts List			
ITEM	QTY	PART NUMBER	DESCRIPTION
1	4	M8-1.25 x 35	HEX TAP BOLT
2	4	5/16"	LOCK WASHER
3	2	7/16-14 x 1.63 x 2.50 C-C	SQ. U-BOLT
4	4	7/16-14	HEX FLANGE NUT

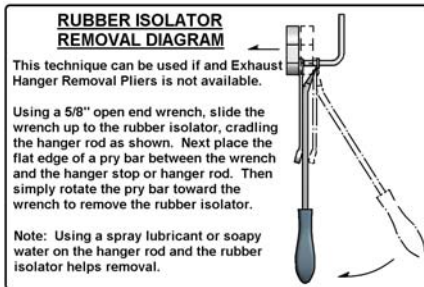
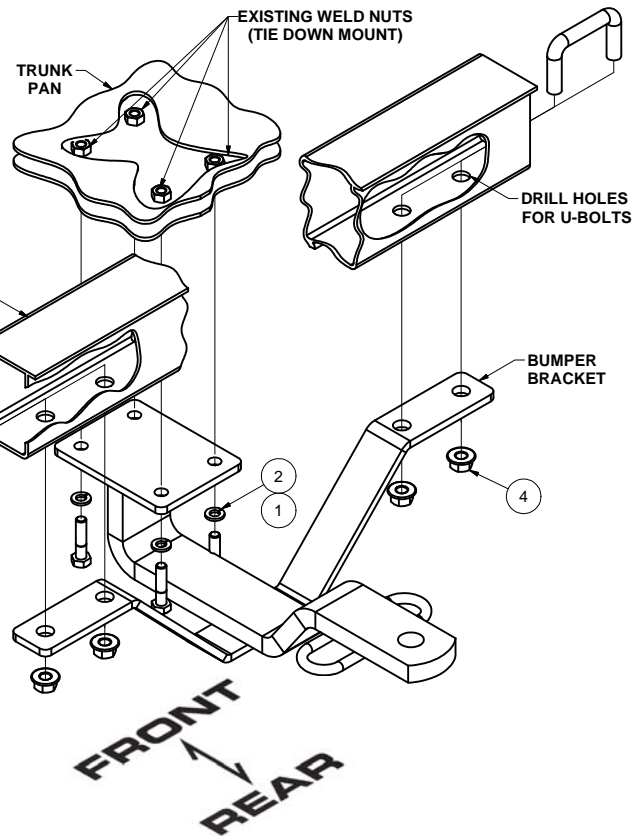
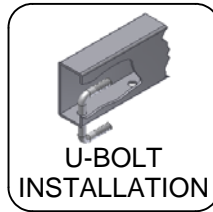

HITCH WEIGHT: 10 LBS.

**INSTALL TIME**

PROFESSIONAL: 45 MINUTES

NOVICE (DIY): 130 MINUTES

**INSTALL NOTES:**

- REMOVE TIE DOWN
- LOWER EXHAUST
- DRILLING REQUIRED
- TRIM FASCIA AND METAL STRIP

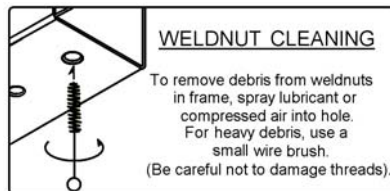

## INSTALLATION STEPS

1. Lower the muffler and heat shield under the rear center of the vehicle as necessary to gain access to the vehicle's tie down bracket. Remove the tie down bracket and return to the vehicle's owner for reinstallation should the hitch ever be removed.
2. Place the hitch into position on the vehicle matching (4) holes in the hitch with (4) holes where the tie down bracket was removed. At the bottom of the bumper, mark the area of the bumper fascia and retainer strip to be trimmed to clear the bumper bracket. Trim the metal retainer and the fascia material as marked. The bumper bracket must fit directly against the steel bumper beam.
3. Place the hitch into position on the vehicle again and temporarily fasten at the chassis where the tie down bracket was removed. Mark and drill the steel bumper beam through the hitch for (4) holes for 1/2" U-bolts. Remove the hitch.
4. Install the (2) U-bolts in the bumper as shown.
5. Place the hitch in position on the vehicle being careful not to push U-bolts out of place. Install remaining fasteners. **DO NOT USE IMPACT WRENCH ON U-BOLTS.**
6. Torque all 8mm fasteners to 18 lb-ft and all 7/16" fasteners to 50 lb-ft.
7. Reinstall exhaust, trim exhaust heat shield if necessary.

PERIODICALLY CHECK THIS RECEIVER HITCH TO ENSURE THAT ALL FASTENERS ARE TIGHT AND THAT ALL STRUCTURAL COMPONENTS ARE SOUND.

Curt Manufacturing Inc., warrants this product to be free of defects in material and/or workmanship at the time of retail purchase by the original purchaser. If the product is found to be defective, Curt Manufacturing Inc., may repair or replace the product, at their option, when the product is returned, prepaid, with proof of purchase. Alteration to, misuse of, or improper installation of this product voids the warranty. Curt Manufacturing Inc.'s liability is limited to repair or replacement of products found to be defective, and specifically excludes liability for incidental or consequential loss or damage.