

**11611****87-91 MITSUBISHI VAN INCLUDING PANEL****GROSS LOAD CAPACITY WHEN USED AS A WEIGHT CARRYING HITCH: 1,500 LBS. TRAILER WEIGHT & 150 LBS. TONGUE WEIGHT.**

\*\*\*DO NOT EXCEED VEHICLE MANUFACTURER'S RECOMMENDED TOWING CAPACITY.\*\*\*

**WARNING: ALL NON-TRAILER LOADS APPLIED TO THIS PRODUCT MUST BE SUPPORTED BY 18050 STABILIZING STRAPS.**

\*\* FAILURE TO PROPERLY SUPPORT NON-TRAILER LOADS WILL VOID PRODUCT WARRANTY\*\*

Parts List			
ITEM	QTY	PART NUMBER	DESCRIPTION
1	2	5_8 - 11 x 2 HEX	HEX TAP BOLT
2	2	5/8-11	HEX FLANGE NUT
3	4	CM-11611-S	.250" BACKING PLATE

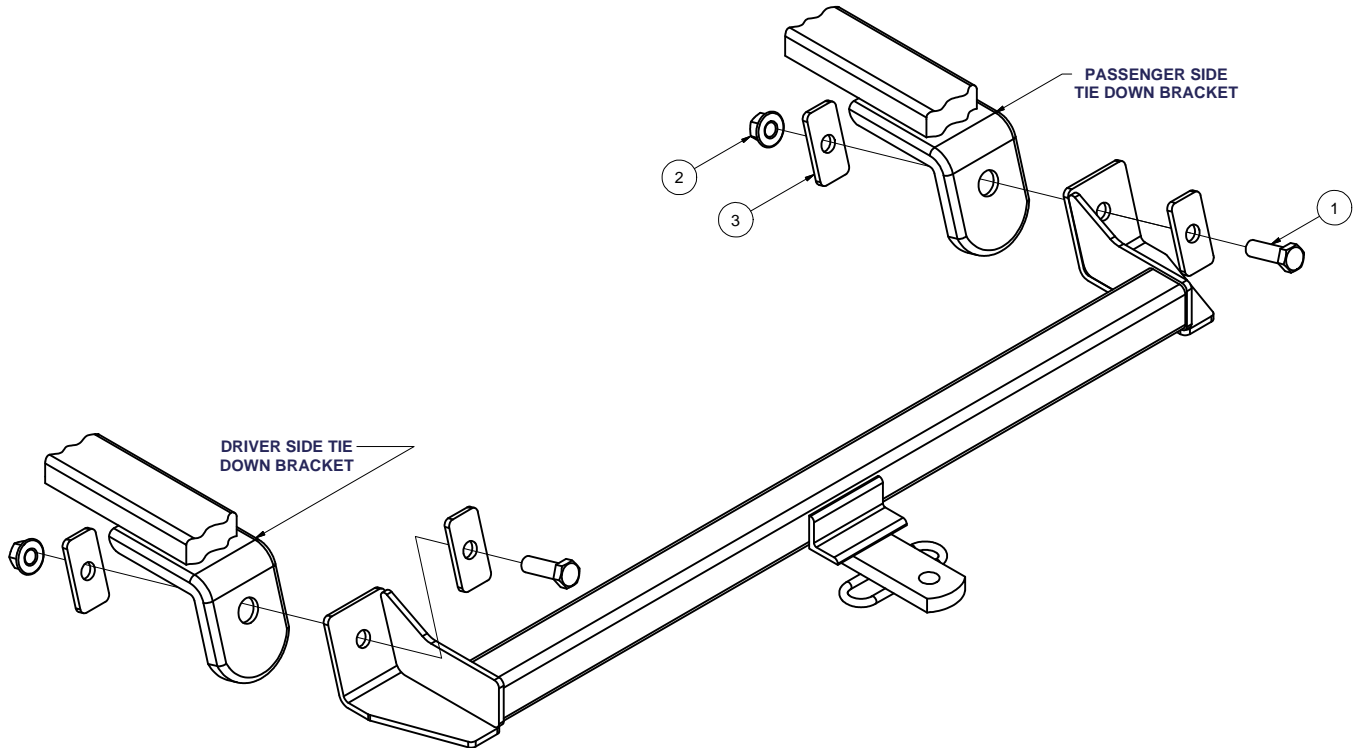
HITCH WEIGHT: 19 LBS.INSTALL TIMEPROFESSIONAL: 15 MINUTESNOVICE (DIY): 30 MINUTESINSTALL NOTES:

- NO DRILLING REQUIRED

**INSTALLATION STEPS**

1. The end brackets welded at each end of the hitch tube bolt directly to the vehicle's tie down brackets as shown. Install bolts as shown with reinforcement plates used on the top of the hitch end brackets and underneath the vehicle's tie down brackets.
2. Torque all 5/8" fasteners to 150 lb-ft.

PERIODICALLY CHECK THIS RECEIVER HITCH TO ENSURE THAT ALL FASTENERS ARE TIGHT AND THAT ALL STRUCTURAL COMPONENTS ARE SOUND.

Curt Manufacturing Inc., warrants this product to be free of defects in material and/or workmanship at the time of retail purchase by the original purchaser. If the product is found to be defective, Curt Manufacturing Inc., may repair or replace the product, at their option, when the product is returned, prepaid, with proof of purchase. Alteration to, misuse of, or improper installation of this product voids the warranty. Curt Manufacturing Inc.'s liability is limited to repair or replacement of products found to be defective, and specifically excludes liability for incidental or consequential loss or damage.