

11543**87-90 NISSAN PULSAR COUPE****GROSS LOAD CAPACITY WHEN USED AS A WEIGHT CARRYING HITCH: 1,500 LBS. TRAILER WEIGHT & 150 LBS. TONGUE WEIGHT.**

DO NOT EXCEED VEHICLE MANUFACTURER'S RECOMMENDED TOWING CAPACITY.

WARNING: ALL NON-TRAILER LOADS APPLIED TO THIS PRODUCT MUST BE SUPPORTED BY AUXILIARY STABILIZING STRAPS.

** FAILURE TO PROPERLY SUPPORT NON-TRAILER LOADS WILL VOID PRODUCT WARRANTY**

Parts List				
ITEM	QTY	PART NUMBER	DESCRIPTION	
1	5	3/8-16 X 1 1/2	HEX BOLT	
2	3	3/8"	FENDER WASHER	
3	5	3/8"	LOCK WASHER	
4	3	3/8 - 16	HEX NUT	
5	1	CM-11543-SPWA	SPACER WELDMENT ASSEMBLY	

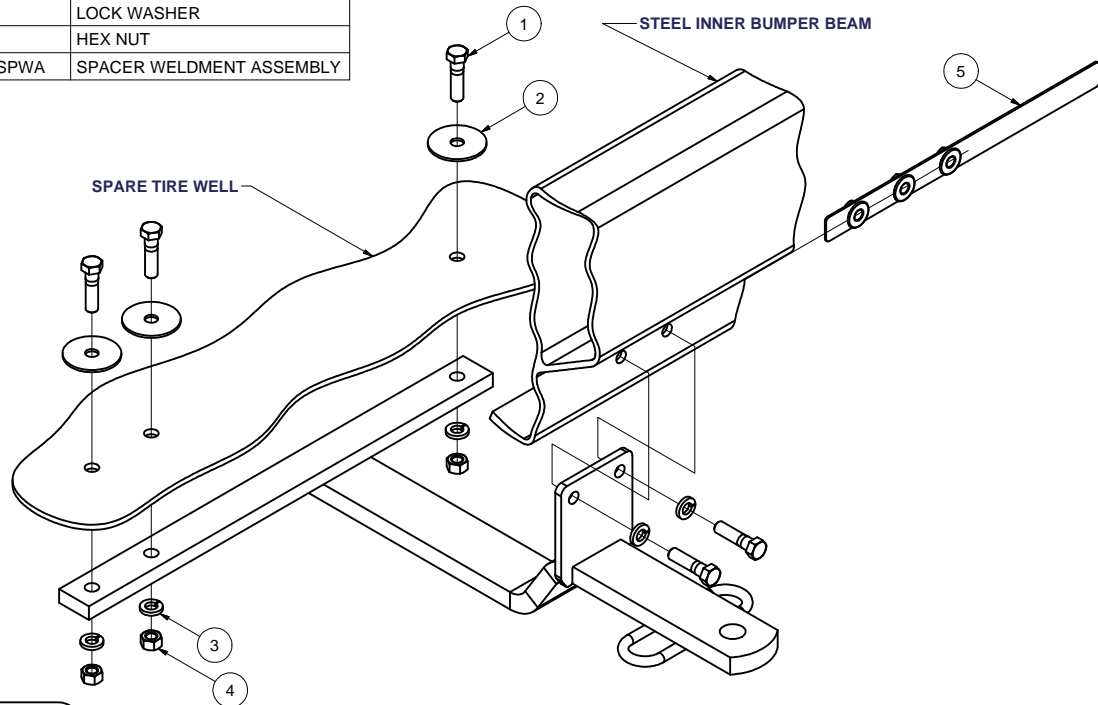

HITCH WEIGHT: 11 LBS.

INSTALL TIME

PROFESSIONAL: 45 MINUTES

NOVICE (DIY): 90 MINUTES

INSTALL NOTES:

- DRILLING REQUIRED
- REMOVE SPARE TIRE
- TRIMMING MAY BE REQUIRED

INSTALLATION STEPS

1. Remove the car's spare tire. Measure and mark the car's centerline on the rear bumper.
2. A piece of the car's bumper cover must be cut away for the hitch bumper bracket to fit directly against the steel inner bumper as shown.
3. Position the hitch centered and square with the car, against the bumper and the spare tire well as shown. Use the hitch as a template to mark the bumper and tire well for the hitch fasteners. Centerpunch and drill the holes for 3/8" diameter fasteners.
4. Bolt the hitch to the bumper using the fasteners indicated. On NX models, a flexible panel may have to be moved or a small piece cut away for wrench access. Bolt the hitch to the spare tire well using fasteners as shown. The 3/8" fender washers must be placed inside the trunk; opposite the hitch.
5. Torque all 3/8" fasteners to 30 lb-ft.

PERIODICALLY CHECK THIS RECEIVER HITCH TO ENSURE THAT ALL FASTENERS ARE TIGHT AND THAT ALL STRUCTURAL COMPONENTS ARE SOUND.

Curt Manufacturing Inc., warrants this product to be free of defects in material and/or workmanship at the time of retail purchase by the original purchaser. If the product is found to be defective, Curt Manufacturing Inc., may repair or replace the product, at their option, when the product is returned, prepaid, with proof of purchase. Alteration to, misuse of, or improper installation of this product voids the warranty. Curt Manufacturing Inc.'s liability is limited to repair or replacement of products found to be defective, and specifically excludes liability for incidental or consequential loss or damage.

Looking for dependable trailer hitches and towing? Rely on CURT for quality and long-lasting products.