

11542

## 1983-1986 NISSAN PULSAR COUPE &amp; NX COUPE

**GROSS LOAD CAPACITY WHEN USED AS A WEIGHT CARRYING HITCH: 1,500 LBS. TRAILER WEIGHT & 150 LBS. TONGUE WEIGHT.**

\*\*\*DO NOT EXCEED VEHICLE MANUFACTURER'S RECOMMENDED TOWING CAPACITY.\*\*\*

**WARNING: ALL NON-TRAILER LOADS APPLIED TO THIS PRODUCT MUST BE SUPPORTED BY 18050 STABILIZING STRAPS.**

\*\* FAILURE TO PROPERLY SUPPORT NON-TRAILER LOADS WILL VOID PRODUCT WARRANTY\*\*

Parts List			
ITEM	QTY	PART NUMBER	DESCRIPTION
1	2	3/8 - 16 x 1 1/4	HEX BOLT
2	4	3/8-16 X 1 1/2	HEX BOLT
3	4	3/8"	FENDER WASHER
4	6	HFN3816	HEX FLANGE NUT

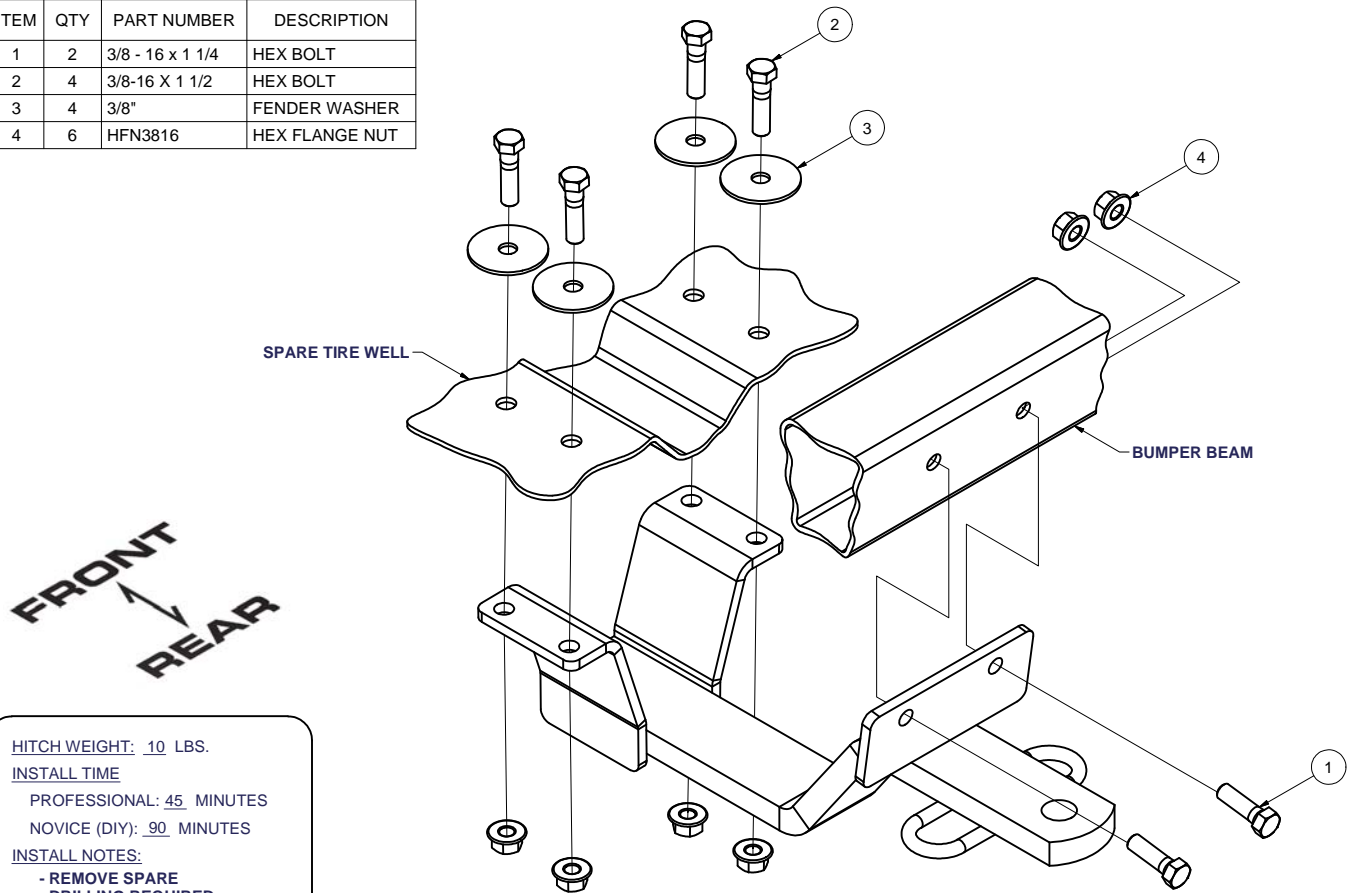

HITCH WEIGHT: 10 LBS.

INSTALL TIME

PROFESSIONAL: 45 MINUTES

NOVICE (DIY): 90 MINUTES

INSTALL NOTES:

- REMOVE SPARE
- DRILLING REQUIRED
- SILICON SEAL HARDWARE

## INSTALLATION STEPS

1. Remove the fasteners from the hitch. Temporarily remove the vehicle's spare tire. Measure and mark the vehicle center line on the rear bumper.
2. A small piece of the rear bumper cover must be cut away. Remove a strip 6 inches long (3 inches on each side of center line) by 1 inch high next to the metal strip at the bumper bottom retaining cover.
3. Position the hitch centered and square with the vehicle, against the steel part of the bumper and spare tire well as shown. Use the hitch as a template to mark the bumper and spare tire well (6) places for 3/8" bolts. Center punch and drill these holes.
4. Bolt the hitch to the bumper using hardware as shown. On NX model, the flexible panel may have to be moved or a small piece cut away to get wrench access to bumper fasteners. Bolt the hitch at the spare tire well using fender washers inside the spare tire well.
5. Torque all 3/8" fasteners to 30 lb-ft.
6. Use silicone sealant to seal hardware installed through spare tire well.
7. Reinstall spare tire.

PERIODICALLY CHECK THIS RECEIVER HITCH TO ENSURE THAT ALL FASTENERS ARE TIGHT AND THAT ALL STRUCTURAL COMPONENTS ARE SOUND.

Curt Manufacturing Inc., warrants this product to be free of defects in material and/or workmanship at the time of retail purchase by the original purchaser. If the product is found to be defective, Curt Manufacturing Inc., may repair or replace the product, at their option, when the product is returned, prepaid, with proof of purchase. Alteration to, misuse of, or improper installation of this product voids the warranty. Curt Manufacturing Inc.'s liability is limited to repair or replacement of products found to be defective, and specifically excludes liability for incidental or consequential loss or damage.

Looking for dependable trailer hitches and towing? Rely on CURT for quality and long-lasting products.