

11510

INFINITI EX35 JOURNEY (AWD INCLUDED)

GROSS LOAD CAPACITY WHEN USED AS A WEIGHT CARRYING HITCH: 1,500 LBS. TRAILER WEIGHT & 150 LBS. TONGUE WEIGHT.

*** DO NOT EXCEED VEHICLE MANUFACTURER'S RECOMMENDED TOWING CAPACITY.***

WARNING: ALL NON-TRAILER LOADS APPLIED TO THIS PRODUCT MUST BE SUPPORTED BY AUXILIARY STABILIZING STRAPS.

** FAILURE TO PROPERLY SUPPORT NON-TRAILER LOADS WILL VOID PRODUCT WARRANTY**

Parts List			
ITEM	QTY	PART NUMBER	DESCRIPTION
1	6	3/8"	CONICAL TOOTHED WASHER
2	2	7/16"	CONICAL TOOTHED WASHER
3	2	M10 - 1.25 x 30	HEX BOLT
4	6	M8 - 1.25 x 30 TAP BOLT	HEX HEAD TAP BOLT

TOOLS REQUIRED
STRAIGHT SCREW DRIVER
RATCHET
3" SOCKET EXTENSION
10" SOCKET EXTENSION
12mm SOCKET
14mm SOCKET
TORQUE WRENCH

RUBBER ISOLATOR REMOVAL DIAGRAM

This technique can be used if and Exhaust Hanger Removal Pliers is not available.

Using a 5/8" open end wrench, slide the wrench up to the rubber isolator, cradling the hanger rod as shown. Next place the flat edge of a pry bar between the wrench and the hanger stop or hanger rod. Then simply rotate the pry bar toward the wrench to remove the rubber isolator.

Note: Using a spray lubricant or soapy water on the hanger rod and the rubber isolator helps removal.

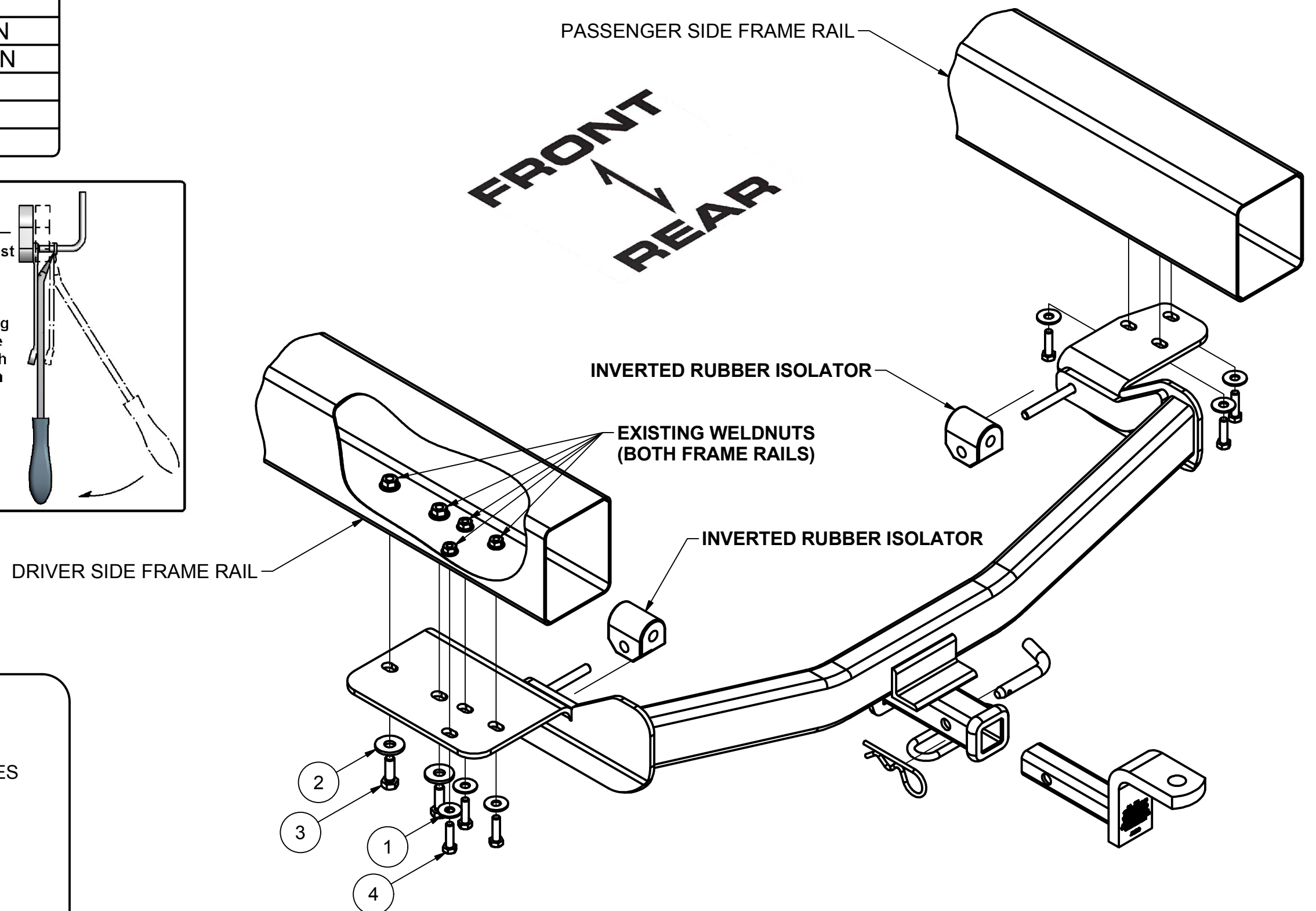

HITCH WEIGHT: 30 LBS.
 INSTALL TIME
 PROFESSIONAL: 60 MINUTES
 NOVICE (DIY): 120 MINUTES
 INSTALL NOTES:
 -NO DRILLING REQUIRED
 -LOWER EXHAUST
 -REMOVE TOW LOOP
 -ATTACH EXHAUST TO HITCH

INSTALLATION STEPS

1. Remove (3) exhaust hanger bolts per side on rear hangers, remove long bolt from driver side hanger on other side of muffler, and remove (1) nut from each of the exhaust hangers just forward from the rear axle. The exhaust should rest on cross brace under the exhaust.
2. Remove exhaust hanger from rubber isolator and return to customer. Remove tow loop and return to customer (both sides).
3. Raise hitch and muffler into position, such that exhaust hanger pegs on muffler are above exhaust hanger studs on hitch. Loosely install the supplied 8mm and 10mm bolts and washers. Invert both of the rubber isolators as shown above.
Note: If hitch and muffler are not raised together, muffler will not be able to be reinstalled with hitch in place.
4. Invert rubber isolators attached to muffler. Install rubber isolators over studs on hitch.
5. Torque all 8mm fasteners to 17 lb-ft and all 10mm fasteners to 37 lb-ft.

PERIODICALLY CHECK THIS RECEIVER HITCH TO ENSURE THAT ALL FASTENERS ARE TIGHT AND THAT ALL STRUCTURAL COMPONENTS ARE SOUND.

Curt Manufacturing Inc., warrants this product to be free of defects in material and/or workmanship at the time of retail purchase by the original purchaser. If the product is found to be defective, Curt Manufacturing Inc., may repair or replace the product, at their option, when the product is returned, prepaid, with proof of purchase. Alteration to, misuse of, or improper installation of this product voids the warranty. Curt Manufacturing Inc.'s liability is limited to repair or replacement of products found to be defective, and specifically excludes liability for incidental or consequential loss or damage.