

**GROSS LOAD CAPACITY WHEN USED AS A WEIGHT CARRYING HITCH: 1,500 LBS. TRAILER WEIGHT & 150 LBS. TONGUE WEIGHT.**

\*\*\*DO NOT EXCEED VEHICLE MANUFACTURER'S RECOMMENDED TOWING CAPACITY.\*\*\*

**WARNING: ALL NON-TRAILER LOADS APPLIED TO THIS PRODUCT MUST BE SUPPORTED BY 18050 STABILIZING STRAPS.**

\*\* FAILURE TO PROPERLY SUPPORT NON-TRAILER LOADS WILL VOID PRODUCT WARRANTY\*\*

| Parts List |     |                  |                     |
|------------|-----|------------------|---------------------|
| ITEM       | QTY | PART NUMBER      | DESCRIPTION         |
| 1          | 2   | M10 - 1.25 x 30  | HEX BOLT            |
| 2          | 2   | 7/16             | HELICAL LOCK WASHER |
| 3          | 2   | 7/16             | WASHER              |
| 4          | 4   | 3/8 - 16 x 1 1/4 | HEX BOLT            |
| 5          | 4   | 3/8"             | FENDER WASHER       |
| 6          | 4   | 3/8"             | LOCK WASHER         |
| 7          | 4   | 3/8 - 16         | HEX NUT             |

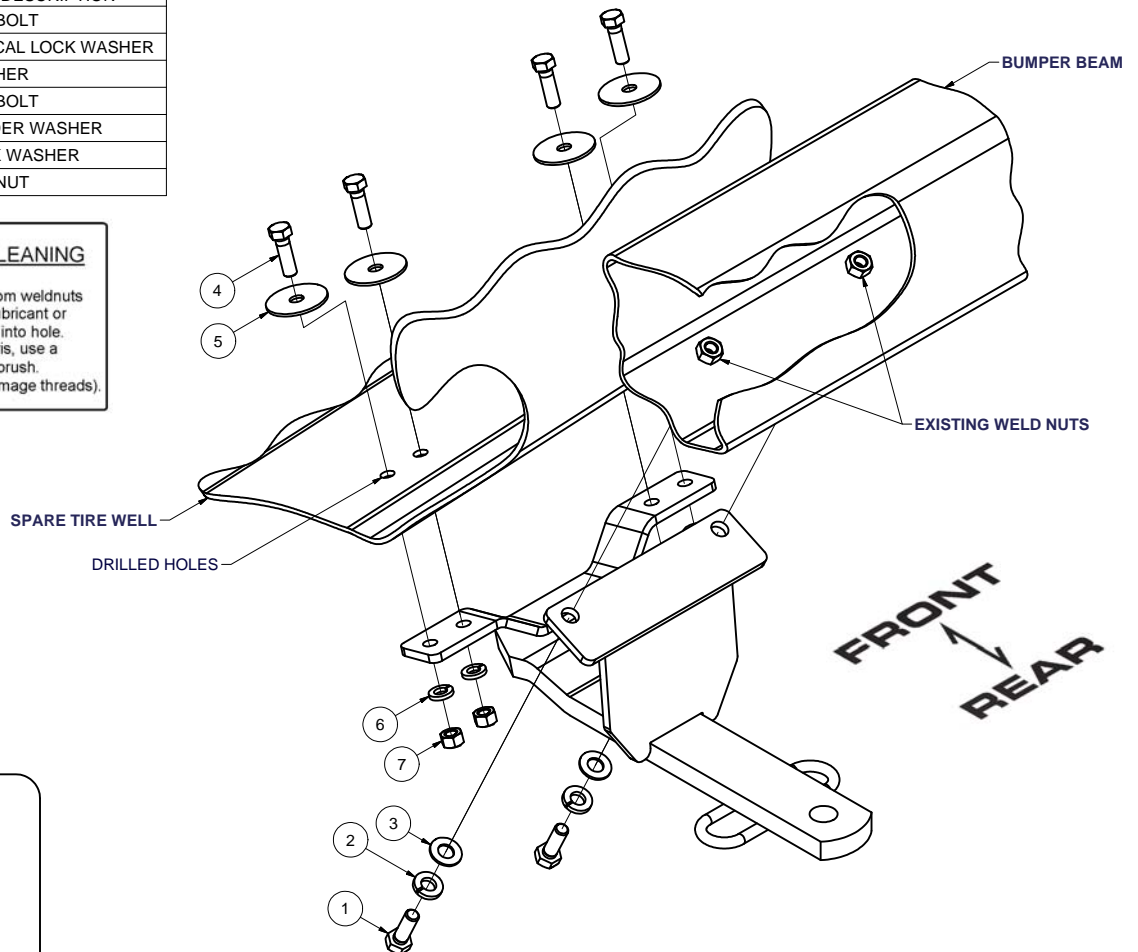
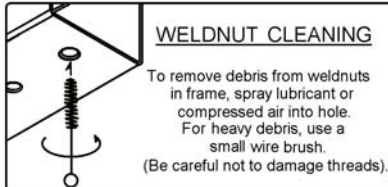

**HITCH WEIGHT:** 9 LBS.

**INSTALL TIME**

PROFESSIONAL: 30 MINUTES

NOVICE (DIY): 60 MINUTES

**INSTALL NOTES:**

- DRILLING REQUIRED
- EMPTY SPARE TIRE WELL
- SILICONE SEAL HARDWARE

## INSTALLATION STEPS

1. Locate the (2) 10mm weldnuts in the bumper's bottom surface at the center of the vehicle.
2. Fasten the hitch to the bumper at these weldnuts as shown.
3. Clear the spare tire well for drilling holes for the tail bracket. Using the hitch as a template, drill the spare tire well through the tail bracket for 3/8" fasteners. Fasten the hitch to car using fasteners shown, making sure the fender washers are used inside the trunk floor opposite the hitch.
4. Torque all 10mm fasteners to 35 lb-ft, and all 3/8" fasteners to 30 lb-ft.
5. Use silicone sealant to seal hardware installed through spare tire well.
6. Reinstall spare tire removed in Step 3.

PERIODICALLY CHECK THIS RECEIVER HITCH TO ENSURE THAT ALL FASTENERS ARE TIGHT AND THAT ALL STRUCTURAL COMPONENTS ARE SOUND.

Curt Manufacturing Inc., warrants this product to be free of defects in material and/or workmanship at the time of retail purchase by the original purchaser. If the product is found to be defective, Curt Manufacturing Inc., may repair or replace the product, at their option, when the product is returned, prepaid, with proof of purchase. Alteration to, misuse of, or improper installation of this product voids the warranty. Curt Manufacturing Inc.'s liability is limited to repair or replacement of products found to be defective, and specifically excludes liability for incidental or consequential loss or damage.