

YEARS: 2012-PRESENT

MAKE: FIAT

MODEL: 500, 500c, 500e

STYLE: HATCHBACK

**WARNING: NEVER EXCEED YOUR VEHICLE MANUFACTURER'S RECOMMENDED TOWING CAPACITY**

**WEIGHT CARRYING:**  
 TRAILER WEIGHT: 2,000 LBS.  
 TONGUE WEIGHT: 200 LBS.

**PRO INSTALL TIME: 40 MIN.**  
**NOVICE INSTALL TIME: 80 MIN.**

*IF YOU ARE HESITANT TO UNDERTAKE THIS TASK ON YOUR OWN, CONTACT AN AUTHORIZED CURT INSTALLER FOR ADDITIONAL ASSISTANCE.*

**INSTALLATION REQUIRES:**

<b>DRILL BIT</b> 7/16"	<b>POWER DRILL</b>	<b>11 mm</b> <b>13 mm</b> <b>11/16"</b> <b>SOCKET</b>
<b>RATCHET</b>	<b>TORQUE WRENCH</b>	<b>SAFETY GLASSES</b>
<b>PRY BAR</b>	<b>AVIATION SHEARS</b>	

**INSTALLATION TIPS:**

- BEFORE YOU BEGIN INSTALLATION, READ ALL INSTRUCTIONS THOROUGHLY.
- TO EASE INSTALLATION, 2 PEOPLE MAY BE REQUIRED.
- USING PROPER TOOLS WILL GREATLY IMPROVE THE QUALITY OF THE INSTALL AND REDUCE THE TIME REQUIRED.

**LEVEL OF DIFFICULTY: MODERATE**

EASY	MODERATE	CHALLENGING
	LOWER EXHAUST	
PART REMOVAL	REMOVE/REINSTALL HEAT SHIELD	
	MAY REQUIRE WELDNUT CLEANING	
	ENLARGE HOLE FOR HARDWARE	
TRIM	- TRIM HEAT SHIELD - TRIM REAR FASCIA	

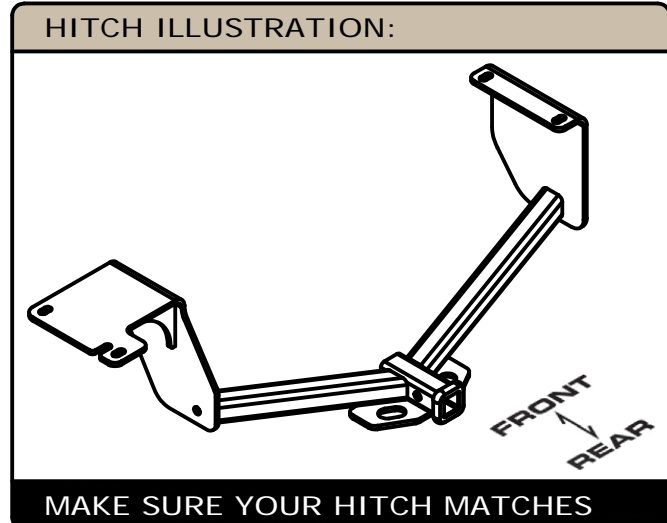

**PERIODICALLY CHECK THIS RECEIVER HITCH TO ENSURE ALL FASTENERS ARE TIGHT AND ALL STRUCTURAL COMPONENTS ARE SOUND**  
 CURT Manufacturing LLC. warrants this product to be free of defects in material and/or workmanship at the time of retail purchase by the original purchaser. If the product is found to be defective, Curt Manufacturing LLC. may repair or replace the product at their option, when the product is returned, prepaid, with proof of purchase. Alteration to, misuse of, or improper installation of this product voids the warranty. Curt Manufacturing LLC.'s liability is limited to repair or replacement of products found to be defective, and specifically excludes liability for incidental or consequential loss or damage.

## INSTALLATION WALKTHROUGH:

Parts List			
ITEM	QTY	PART NUMBER	DESCRIPTION
1	2	M8 - 1.25 x 30	HEX HEAD BOLT
2	2	3/8"	TOOTHED WASHER
3	2	7/16 FISHWIRE	7/16" FISHWIRE
4	2	7/16-14	HEX FLANGE NUT
5	2	7/16-14 x 1 1/4	CARRIAGE BOLT
6	2	CM-SP2	SPACER

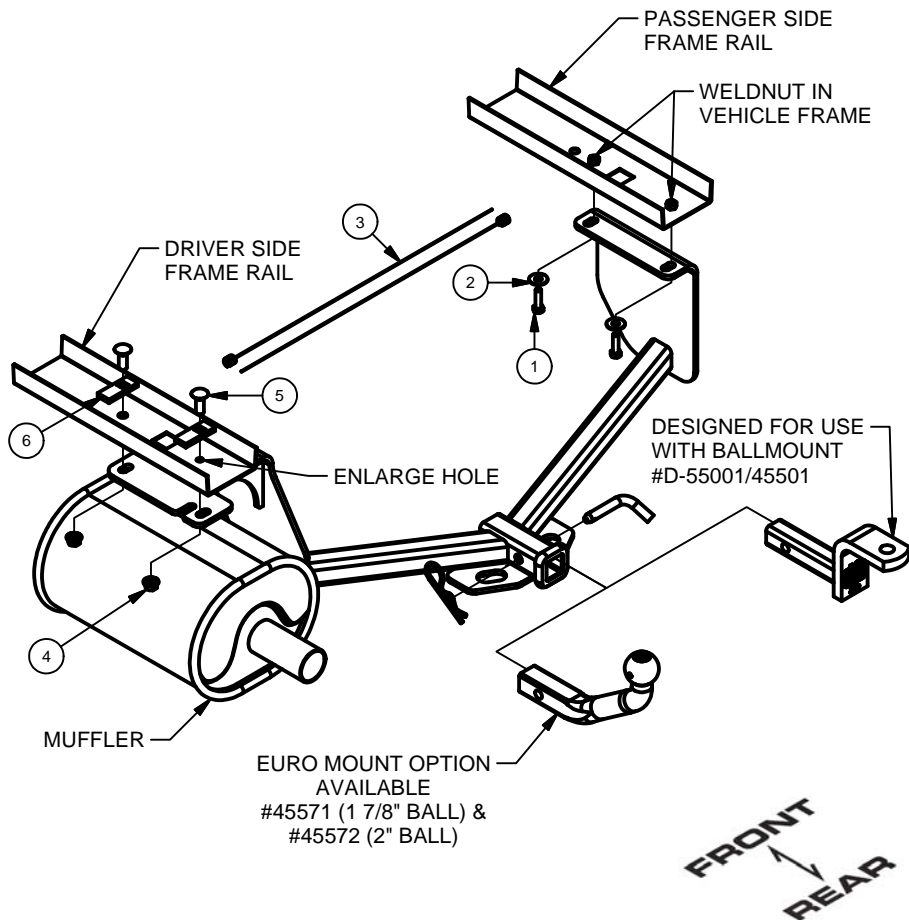

1. Lower exhaust by removing rubber exhaust hanger from hanger rod, two (2) places. Remove heat shield by removing four (4) hex nuts.  
**Note:** Heat shield will be modified and reinstalled using two (2) hex nuts.

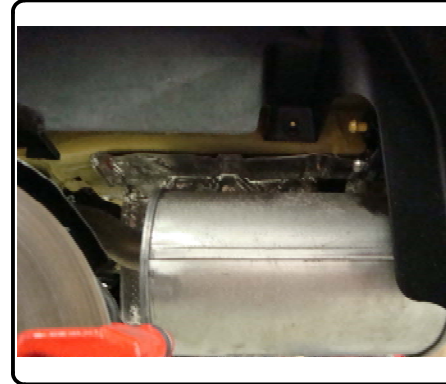

2. If vehicle is equipped with a spare tire, remove two (2) bolts which attach spare tire control box to passenger side frame rail.  
**Note:** If vehicle does not have spare tire option, weldnuts can be found by removing protective tape from frame rail. Remove square plug from frame rails to reveal square access holes in frame. Return plugs to vehicle owner.

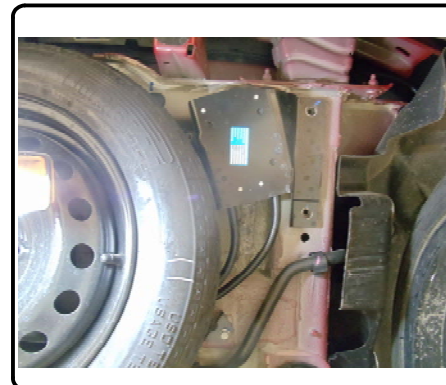

## INSTALLATION WALKTHROUGH:

- Using a 7/16" drill bit, enlarge hole at end of driver side frame rail. On driver side, fishwire 7/16" carriage bolts and spacer blocks up through square hole and down through mounting holes as shown.



- Raise hitch into position, taking care not to push carriage bolts back into frame and sandwiching hitch passenger side plate between frame rail and spare tire control box, if equipped. Install M8 hex bolts and 7/16" conical toothed washers into weldnuts in passenger side frame rail. Install flanged hex nuts onto carriage bolts in driver side frame rail. Torque all 7/16" fasteners to 70 lb.-ft.; Torque all M8 fasteners to 23 lb.-ft.

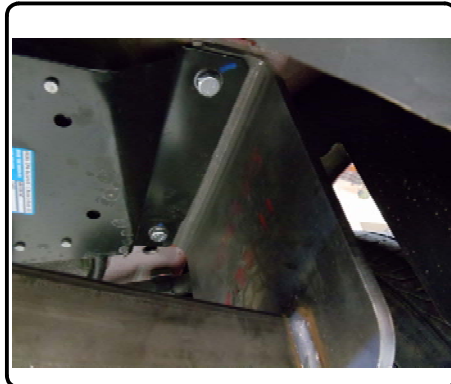

- Trim heat shield as shown and install heat shield using two (2) hex nuts removed in step 1 and discard the other two (2) hex nuts. Raise exhaust back into position by reattaching rubber exhaust hangers to hanger rods.
- On 500 Turbo vehicles, the center fin portion of the rear fascia will need to be trimmed at the bottom before the hitch can be installed. Reference the trim diagram for trimming dimensions.

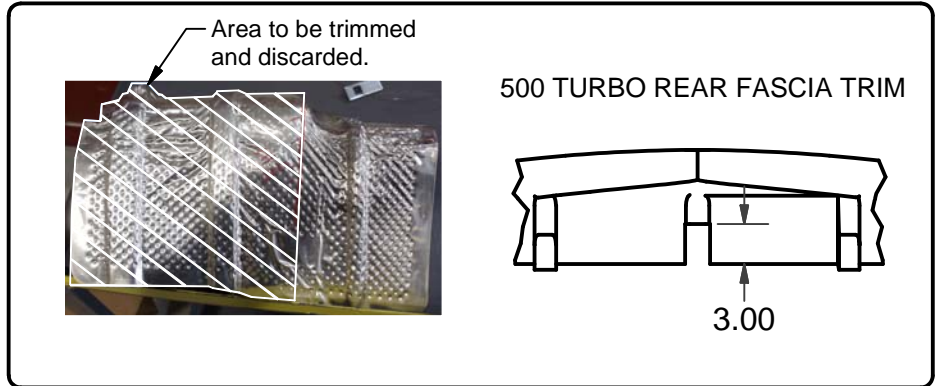

Install is complete.



11363

FIAT 500, 500c & 500e

GROSS LOAD CAPACITY WHEN USED AS A WEIGHT CARRYING HITCH: 2,000 LBS. TRAILER WEIGHT & 200 LBS. TONGUE WEIGHT.

\*\*\*DO NOT EXCEED VEHICLE MANUFACTURER'S RECOMMENDED TOWING CAPACITY.\*\*\*

WARNING: ALL NON-TRAILER LOADS APPLIED TO THIS PRODUCT MUST BE SUPPORTED BY 18050 STABILIZING STRAPS.

\*\* FAILURE TO PROPERLY SUPPORT NON-TRAILER LOADS WILL VOID PRODUCT WARRANTY\*\*

Parts List				
ITEM	QTY	PART NUMBER	DESCRIPTION	
1	2	M8 - 1.25 x 30	HEX HEAD BOLT	
2	2	3/8"	CONICAL TOOTHED WASHER	
3	2	7_16 FISHWIRE	7/16" FISHWIRE	
4	2	7/16-14	HEX FLANGE NUT	
5	2	7/16-14 x 1 1/4	CARRIAGE BOLT	
6	2	CM-SP2	.250 x .88 x 2.25" SQUARE HOLE SPACER	

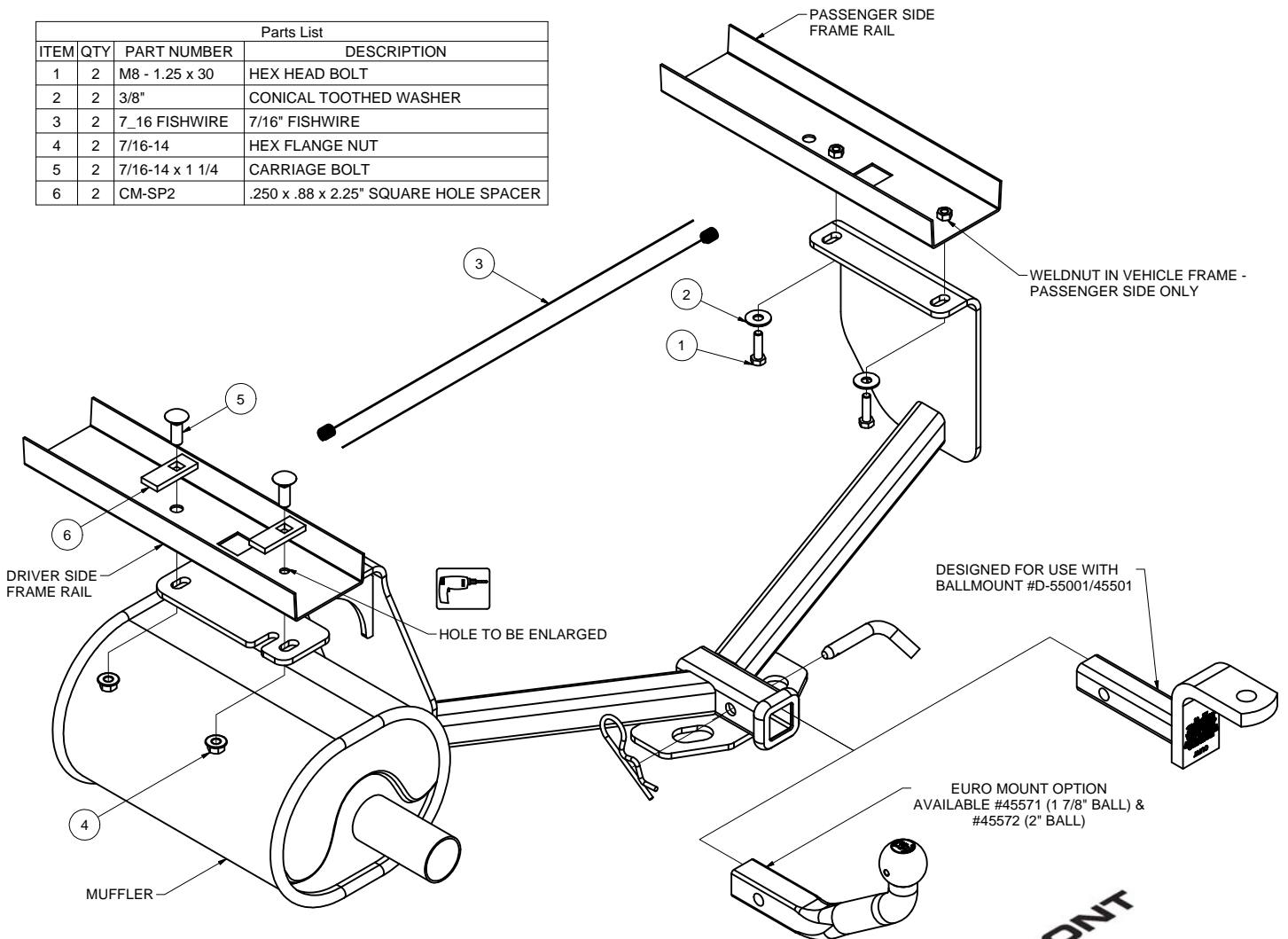

TOOLS REQUIRED
RATCHET
PRY BAR
11mm SOCKET
13mm SOCKET
11/16" SOCKET
TORQUE WRENCH
7/16" DRILL BIT
POWER DRILL

HITCH WEIGHT: 29 LBS.  
 INSTALL TIME  
 PROFESSIONAL: 40 MINUTES  
 NOVICE (DIY): 80 MINUTES  
 INSTALL NOTES:  
 -LOWER EXHAUST  
 -HOLE ENLARGEMENT REQUIRED  
 -FISHWIRE HARDWARE  
 -TRIM HEAT SHIELD & FASCIA

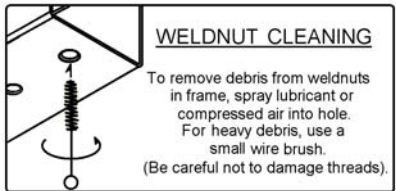
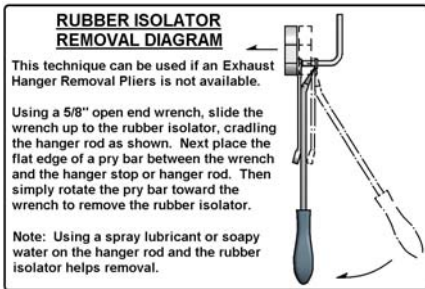

PERIODICALLY CHECK THIS RECEIVER HITCH TO ENSURE THAT ALL FASTENERS ARE TIGHT AND THAT ALL STRUCTURAL COMPONENTS ARE SOUND.



HEAT SHIELD TRIM DIAGRAM

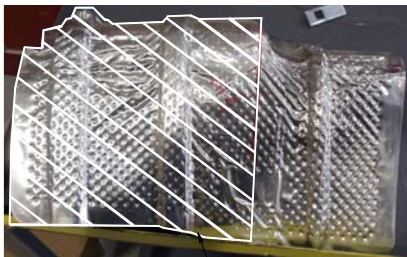

AREA TO BE TRIMMED  
AND DISCARDED

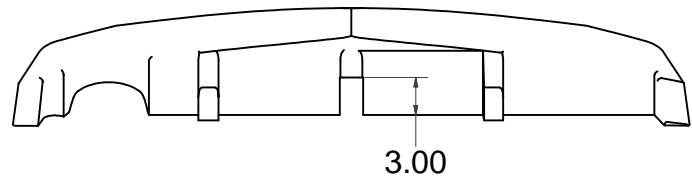
500 TURBO  
REAR FASCIA TRIM DIAGRAM

3.00

### INSTALLATION STEPS

1. Lower exhaust by removing rubber exhaust hanger from hanger rod, two places. If vehicle is equipped with heat shield, remove by removing four (4) hex nuts.  
**Note:** Heat shield will be modified and reinstalled using two (2) hex nuts.
2. If vehicle is equipped with a spare tire, remove two bolts which attach spare tire control box to passenger side frame rail. Remove square rubber plug from frame rails to reveal square holes in frame. Return plugs to vehicle owner.  
**Note:** If vehicle does not have spare tire option, weldnuts can be found by removing protective tape from frame rail.
3. Using a 7/16" drill bit, enlarge hole at end of driver side frame rail. On driver side, fishwire 7/16" carriage bolts and spacer blocks up through square hole and down through mounting holes as shown.
4. On 500 Turbo vehicles, the center fin portion of the rear fascia will need to be trimmed at the bottom before the hitch can be installed. Reference the trim diagram for trimming dimensions.
5. Raise hitch into position, taking care not to push carriage bolts back into frame and sandwiching hitch passenger side plate between frame rail and spare tire control box, if equipped. Install M8 hex bolts and 7/16" conical toothed washers into weldnuts in passenger side frame rail. Install flanged hex nuts onto carriage bolts in driver side frame rail. Torque all 7/16" fasteners to 70 lb.-ft.; Torque all M8 fasteners to 23 lb.-ft.
6. Trim heat shield as shown in trim diagram and install heat shield using two (2) hex nuts removed in Step 2 and discard the other two (2) hex nuts.  
Raise exhaust back into position by reattaching rubber exhaust hangers to hanger rods.

PERIODICALLY CHECK THIS RECEIVER HITCH TO ENSURE THAT ALL FASTENERS  
ARE TIGHT AND THAT ALL STRUCTURAL COMPONENTS ARE SOUND.