



Safety glasses should be worn at all times while installing this product.

YEARS: 2013-PRESENT

MAKE: CHEVROLET

MODEL: SPARK (LS & 1LT MODELS W/ STANDARD REAR FASCIA)

STYLE: HATCHBACK

WARNING: NEVER EXCEED YOUR VEHICLE MANUFACTURER'S RECOMMENDED TOWING CAPACITY

WEIGHT CARRYING:
TRAILER WEIGHT: 2,000 LBS.
TONGUE WEIGHT: 200 LBS.

INSTALLATION TIME: 20/45 MIN.

THE INSTALL TIME LISTED IS FOR PROFESSIONAL/NOVICE INSTALLERS. IF YOU ARE HESITANT TO UNDERTAKE THIS TASK ON YOUR OWN, CONTACT AN AUTHORIZED CURT INSTALLER FOR ADDITIONAL ASSISTANCE.

INSTALLATION TIPS:

- BEFORE YOU BEGIN INSTALLATION, READ ALL INSTRUCTIONS THOROUGHLY.
- TO EASE INSTALLATION, 2 PEOPLE MAY BE REQUIRED.
- USING PROPER TOOLS WILL GREATLY IMPROVE THE QUALITY OF THE INSTALL AND REDUCE THE TIME REQUIRED.

VEHICLE PHOTO:





REPRESENTATIVE PHOTO

INSTALLATION REQUIRES:

 DIE GRINDER	 PRY BAR	 RATCHET
 SAFETY GLASSES	 SPRAY LUBRICANT	 11/16 3/4 SOCKET
 TORQUE WRENCH		

LEVEL OF DIFFICULTY: MODERATE

<i>EASY</i>	<i>MODERATE</i>	<i>CHALLENGING</i>
	REVERSE FISHWIRE HARDWARE	
	TEMPORARILY LOWER EXHAUST	
	HOLE ENLARGEMENT REQUIRED	

HITCH ILLUSTRATION:

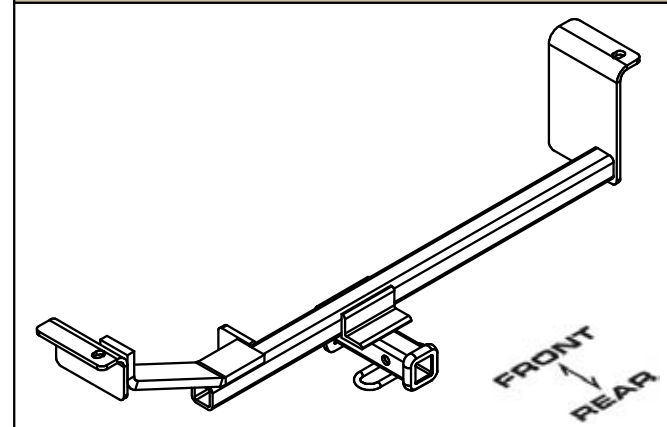

MAKE SURE YOUR HITCH MATCHES

PERIODICALLY CHECK THIS RECEIVER HITCH TO ENSURE ALL FASTENERS ARE TIGHT AND ALL STRUCTURAL COMPONENTS ARE SOUND

CURT Manufacturing LLC. warrants this product to be free of defects in material and/or workmanship at the time of retail purchase by the original purchaser. If the product is found to be defective, Curt Manufacturing LLC. may repair or replace the product at their option, when the product is returned, prepaid, with proof of purchase. Alteration to, misuse of, or improper installation of this product voids the warranty. Curt Manufacturing LLC.'s liability is limited to repair or replacement of products found to be defective, and specifically excludes liability for incidental or consequential loss or damage.

INSTALLATION WALKTHROUGH:

Parts List			
ITEM	QTY	PART NUMBER	DESCRIPTION
1	2	7/16 - 14 x 1 3/4	CARRIAGE BOLT
2	2	CM-SP2	.250 x .88 x 2.25" SPACER
3	2	7/16-14	HEX FLANGE NUT
4	2	7_16 FISHWIRE	7/16" FISHWIRE
5	1	1/2-13 x 1 3/4	CARRIAGE BOLT
6	1	CM-SP26	.250 x 1.50 x 2.25" SPACER
7	1	HFN 1213	HEX FLANGE NUT

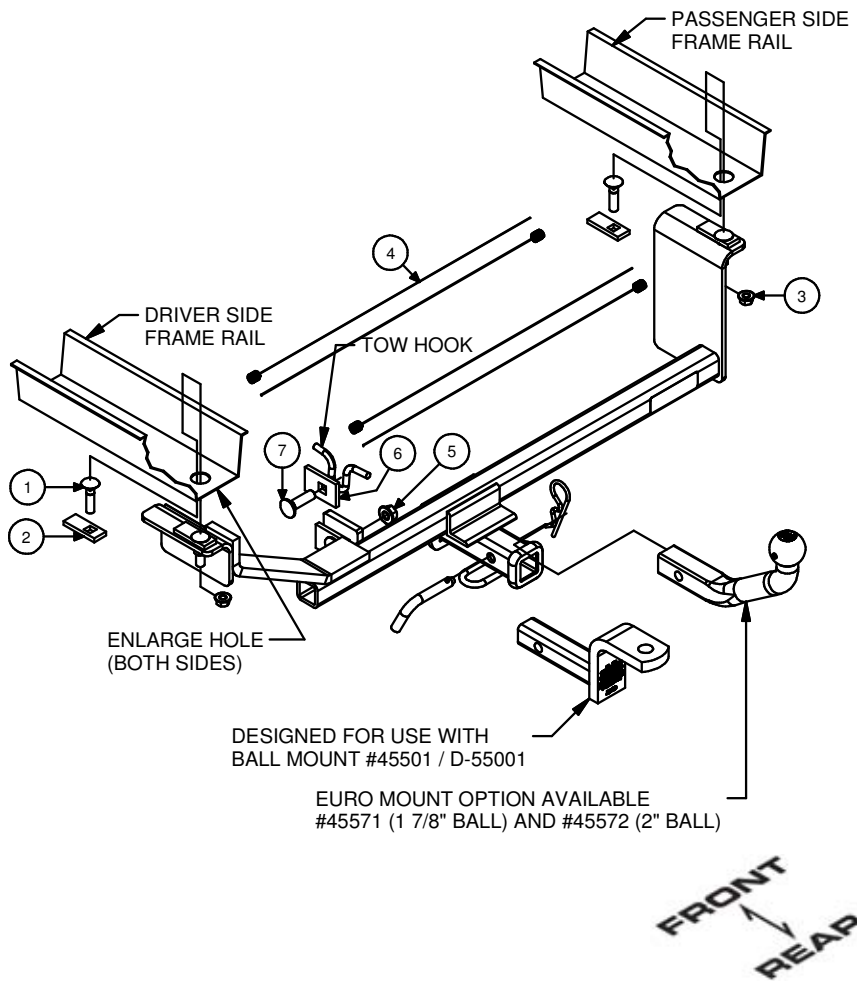

1. Lower exhaust by disconnecting exhaust hangers from rubber isolators, one forward and one rearward of muffler.



2. Enlarge hole at the end of each frame rail to accommodate square hole spacers and 7/16" carriage bolts.



INSTALLATION WALKTHROUGH:

3. Reverse fishwire square hole spacers and 7/16" carriage bolts up through hole enlarged in Step 2 and back down through same hole.



5. Install 1/2" carriage bolt with large square hole spacer through tow hook and support bar on hitch and fasten with 1/2" flange nut, as shown.



4. Raise hitch into position and loosely attach 7/16" hex flange nuts to carriage bolts.



6. Torque 7/16" hardware to 70 lb-ft.
Torque 1/2" hardware to 110 lb-ft.

Installation is complete

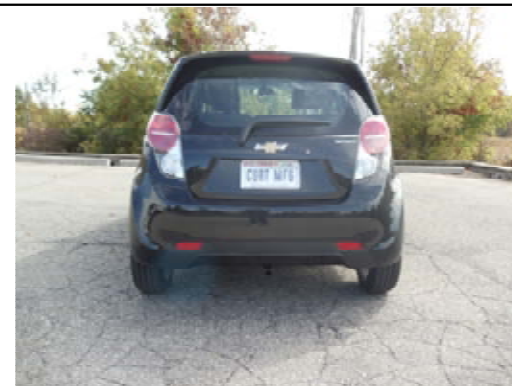

11334

CHEVROLET SPARK (LS & 1LT MODELS W/ STANDARD REAR FASCIA)

GROSS LOAD CAPACITY WHEN USED AS A WEIGHT CARRYING HITCH: 2,000 LBS. TRAILER WEIGHT & 200 LBS. TONGUE WEIGHT.

*****DO NOT EXCEED VEHICLE MANUFACTURER'S RECOMMENDED TOWING CAPACITY.*****

WARNING: ALL NON-TRAILER LOADS APPLIED TO THIS PRODUCT MUST BE SUPPORTED BY 18050 STABILIZING STRAPS.

Parts List			
ITEM	QTY	PART NUMBER	DESCRIPTION
1	2	7/16 - 14 x 1 3/4	CARRIAGE BOLT
2	2	CM-SP2	.250 x .88 x 2.25" SPACER
3	2	7/16-14	HEX FLANGE NUT
4	2	7_16 FISHWIRE	7/16" FISHWIRE
5	1	1/2-13 x 1 3/4	CARRIAGE BOLT
6	1	CM-SP26	.250 x 1.50 x 2.25" SPACER
7	1	HFN 1213	HEX FLANGE NUT

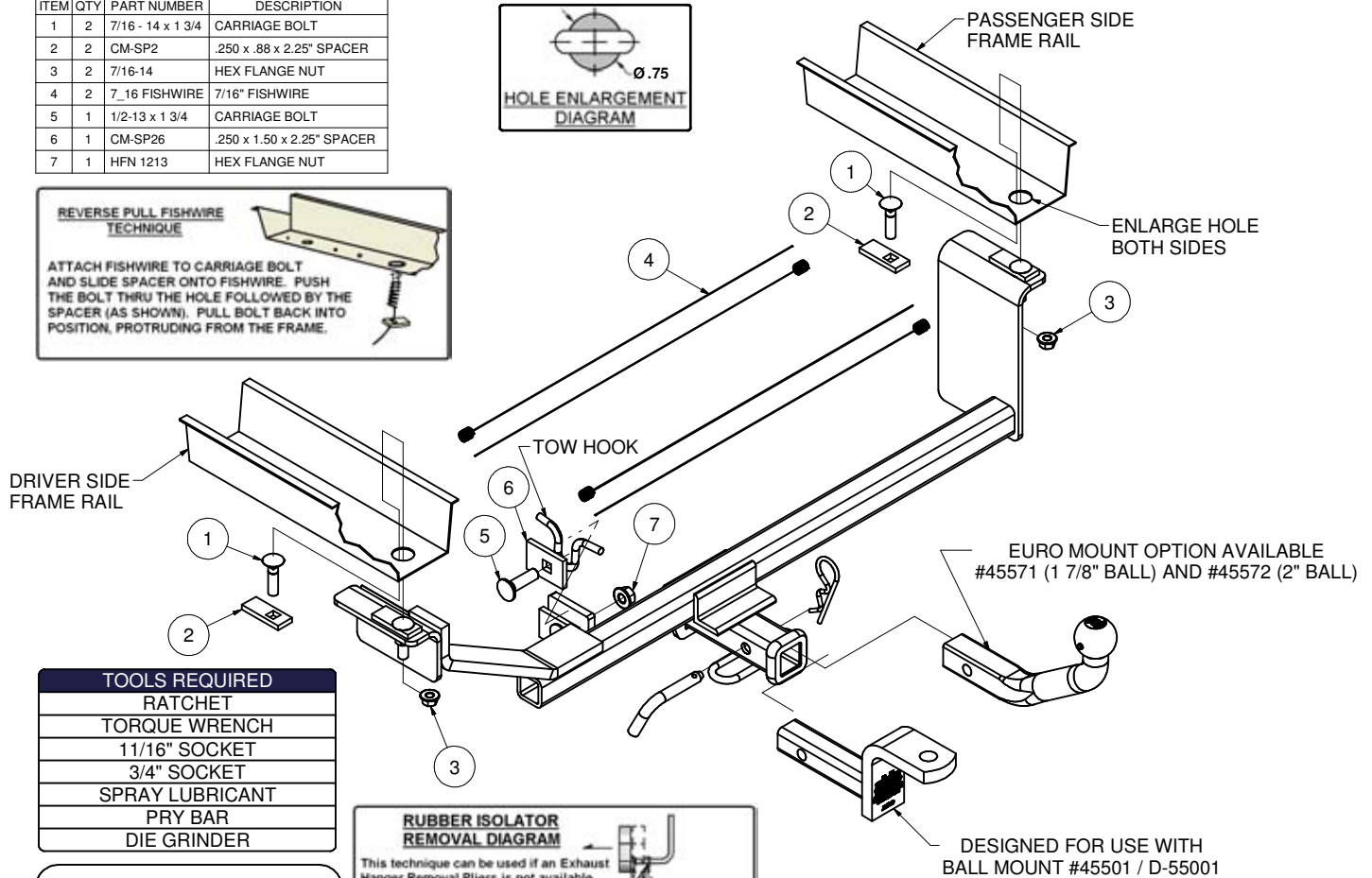
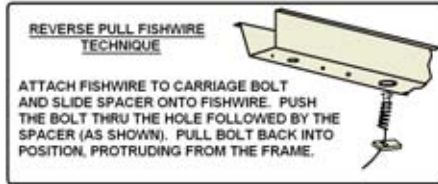
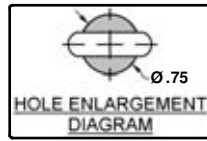

TOOLS REQUIRED
RATCHET
TORQUE WRENCH
11/16" SOCKET
3/4" SOCKET
SPRAY LUBRICANT
PRY BAR
DIE GRINDER

HITCH WEIGHT: 20 LBS.
INSTALL TIME
 PROFESSIONAL: 20 MINUTES
 NOVICE (DIY): 45 MINUTES
INSTALL NOTES:
 - NO DRILLING REQUIRED
 - REVERSE FISHWIRE HARDWARE
 - LOWER EXHAUST
 - HOLE ENLARGEMENT REQUIRED

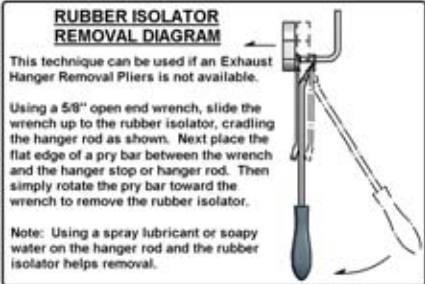

FRONT
REAR

INSTALLATION STEPS

1. Lower exhaust by disconnecting exhaust hangers from rubber isolators, one forward and one rearward of muffler.
2. Enlarge hole at the end of each frame rail to accommodate square hole spacers and 7/16" carriage bolts.
3. Reverse fishwire square hole spacers and 7/16" carriage bolts up through hole enlarged in Step 2 and back down through same hole.
4. Raise hitch into position and loosely attach 7/16" hex flange nuts to carriage bolts.
5. Install 1/2" carriage bolt with large square hole spacer through tow hook and support bar on hitch and fasten with 1/2" hex flange nut, as shown.
6. Torque 7/16" hardware to 70 lb-ft. Torque 1/2" hardware to 110 lb-ft.
7. Raise exhaust back into position.

PERIODICALLY CHECK THIS RECEIVER HITCH TO ENSURE THAT ALL FASTENERS ARE TIGHT AND THAT ALL STRUCTURAL COMPONENTS ARE SOUND.