



Safety glasses should be worn at all times while installing this product.

YEARS: 2012

MAKE: HYUNDAI & KIA

MODEL: ACCENT & RIO SEDAN

STYLE: COMPACT

WARNING: NEVER EXCEED YOUR VEHICLE MANUFACTURER'S RECOMMENDED TOWING CAPACITY

WEIGHT CARRYING:
 TRAILER WEIGHT: 2,000 LBS.
 TONGUE WEIGHT: 200 LBS.

INSTALLATION TIME: 30 MIN.

THE INSTALL TIME LISTED IS FOR PROFESSIONAL INSTALLERS. IF YOU ARE HESITANT TO UNDERTAKE THIS TASK ON YOUR OWN, CONTACT AN AUTHORIZED CURT INSTALLER FOR ADDITIONAL ASSISTANCE.



INSTALLATION REQUIRES:

 RATCHET	 TORQUE WRENCH	 11/16" 9/16" SOCKET
 SAFETY GLASSES	 DRILL BIT 15/32"	 POWER DRILL

INSTALLATION TIPS:

- BEFORE YOU BEGIN INSTALLATION, READ ALL INSTRUCTIONS THOROUGHLY.
- TO EASE INSTALLATION, 2 PEOPLE MAY BE REQUIRED.
- USING PROPER TOOLS WILL GREATLY IMPROVE THE QUALITY OF THE INSTALL AND REDUCE THE TIME REQUIRED.

LEVEL OF DIFFICULTY: EASY

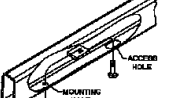
EASY	MODERATE	CHALLENGING
 PART REMOVAL	Remove rubber plugs (if present)	
	"Reverse pull" fishwire (2) bolts and (2) spacers	
 ACCESS HOLE SECURING HOLE	Fishwire (2) bolts and (2) spacers	

VEHICLE PHOTO:



REPRESENTATIVE PHOTO

HITCH ILLUSTRATION:

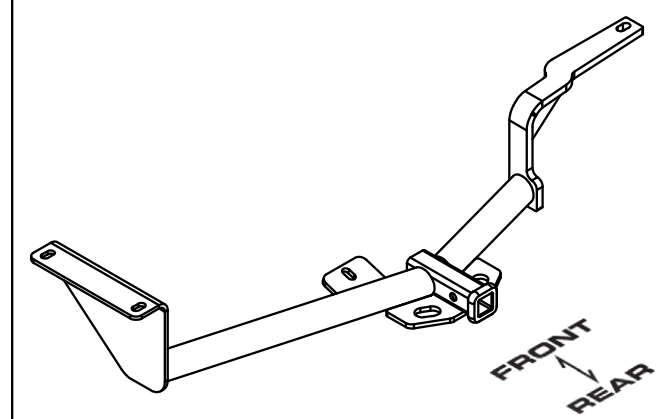

MAKE SURE YOUR HITCH MATCHES

PERIODICALLY CHECK THIS RECEIVER HITCH TO ENSURE ALL FASTENERS ARE TIGHT AND ALL STRUCTURAL COMPONENTS ARE SOUND

CURT Manufacturing LLC. warrants this product to be free of defects in material and/or workmanship at the time of retail purchase by the original purchaser. If the product is found to be defective, Curt Manufacturing LLC. may repair or replace the product at their option, when the product is returned, prepaid, with proof of purchase. Alteration to, misuse of, or improper installation of this product voids the warranty. Curt Manufacturing LLC.'s liability is limited to repair or replacement of products found to be defective, and specifically excludes liability for incidental or consequential loss or damage.

INSTALLATION WALKTHROUGH:

Parts List			
ITEM	QTY	PART NUMBER	DESCRIPTION
1	2	7/16-14 x 1 1/4	CARRIAGE BOLT
2	3	7/16-14	HEX FLANGE NUT
3	3	CM-SP2	.250 x .88 x 2.25" SQUARE HOLE SPACER
4	1	CM-SP34	.188 x 1.50 x 3.00" ROUND HOLE SPACER
5	1	3/8-16 X 1 1/2	HEX BOLT
6	1	3/8"	WASHER
7	1	HFN3816	HEX FLANGE NUT
8	2	7_16 FISHWIRE	7/16" FISHWIRE
9	1	7/16-14 x 1 1/2	CARRIAGE BOLT

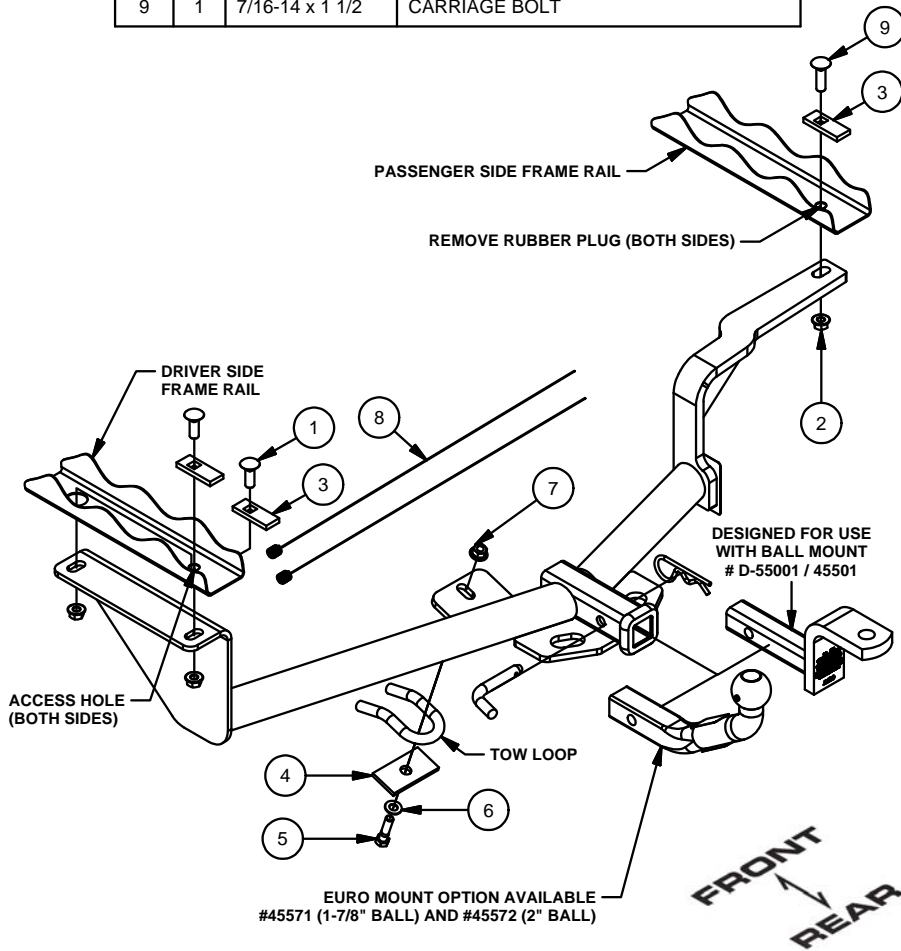

1. If present, Remove rubber plugs from frame holes and return to owner.



2. Raise hitch into position with the tow loop mounting tab resting on top of the tow hook. Mark the forward hole on the driver side frame rail and drill with a 15/32" drill bit. Remove hitch. **Note:** Hyundai Accent sedan does not require drilling.

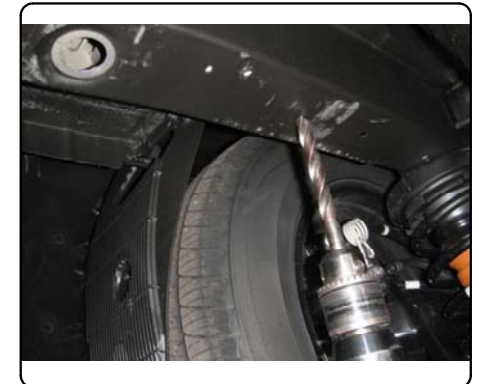

INSTALLATION WALKTHROUGH:

3. Fishwire (1) 7/16" carriage bolt and (1) CM-SP2 spacer through the access hole into the forward hole on the driver side. Reverse Fishwire (1) 7/16" carriage bolt and (1) CM-SP2 spacer into the access hole on each side.

Note: The access hole location will vary depending on the vehicle model.



4. Raise the hitch back into position. Be careful not to push the carriage bolts back into the frame. Loosely install (4) 7/16" hex flange nuts.



5. Install the remaining 3/8" hardware with (1) CM-SP34 spacer onto the vehicle tow loop, as shown above.



6. Torque all 3/8" fasteners to 30 lb-ft and all 7/16" fasteners to 50 lb-ft.

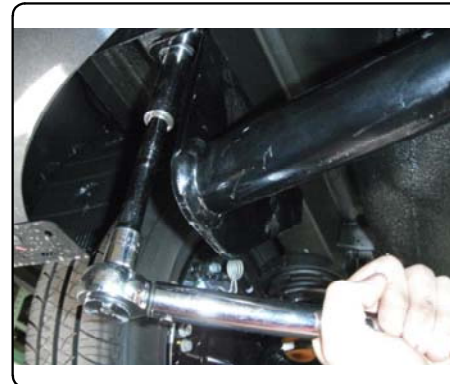

11250

HYUNDAI ACCENT & KIA RIO SEDAN

GROSS LOAD CAPACITY WHEN USED AS A WEIGHT CARRYING HITCH: 2,000 LBS. TRAILER WEIGHT & 200 LBS. TONGUE WEIGHT.

DO NOT EXCEED VEHICLE MANUFACTURER'S RECOMMENDED TOWING CAPACITY.

WARNING: ALL NON-TRAILER LOADS APPLIED TO THIS PRODUCT MUST BE SUPPORTED BY 18050 STABILIZING STRAPS.

** FAILURE TO PROPERLY SUPPORT NON-TRAILER LOADS WILL VOID PRODUCT WARRANTY**

Parts List			
ITEM	QTY	PART NUMBER	DESCRIPTION
1	2	7/16-14 x 1 1/4	CARRIAGE BOLT
2	3	7/16-14	HEX FLANGE NUT
3	3	CM-SP2	.250 x .88 x 2.25" SQUARE HOLE SPACER
4	1	CM-SP34	.188 x 1.50 x 3.00" ROUND HOLE SPACER
5	1	3/8-16 X 1 1/2	HEX BOLT
6	1	3/8"	WASHER
7	1	HFN3816	HEX FLANGE NUT
8	2	7_16 FISHWIRE	7/16" FISHWIRE
9	1	7/16-14 x 1 1/2	CARRIAGE BOLT

TOOLS REQUIRED
RATCHET
TORQUE WRENCH
11/16" SOCKET
9/16" SOCKET
DRILL
15/32" DRILL BIT

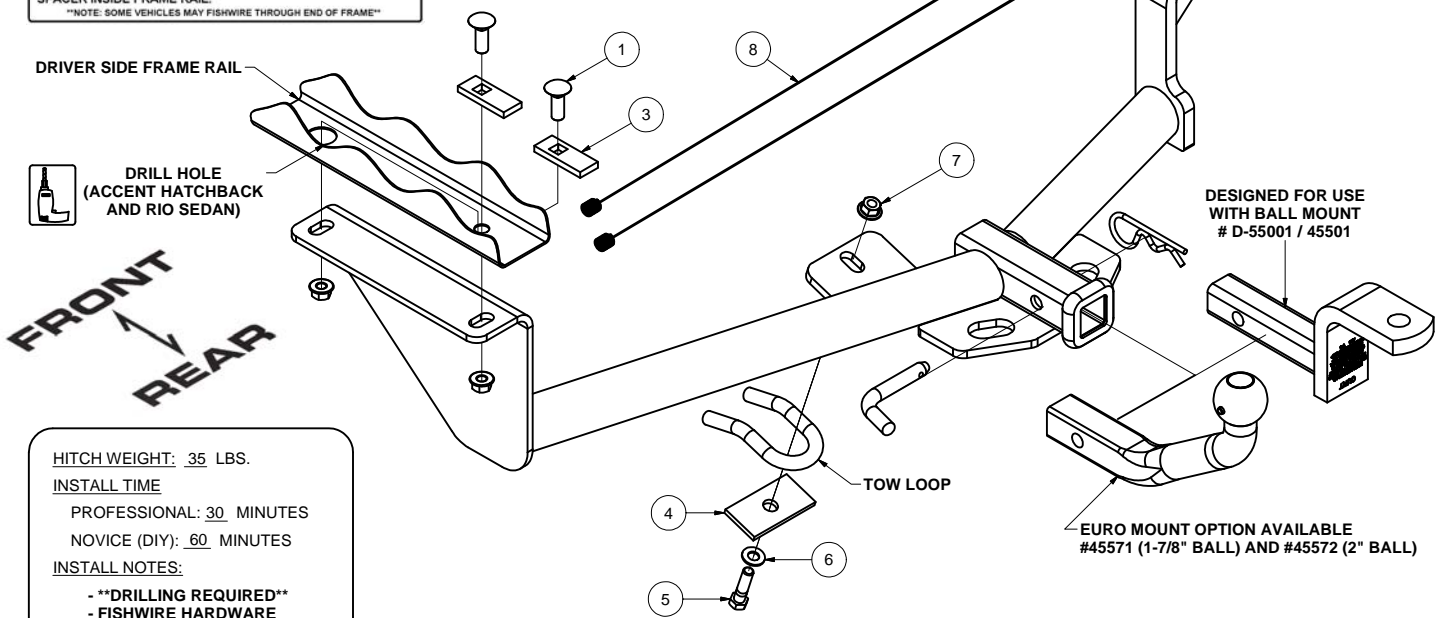
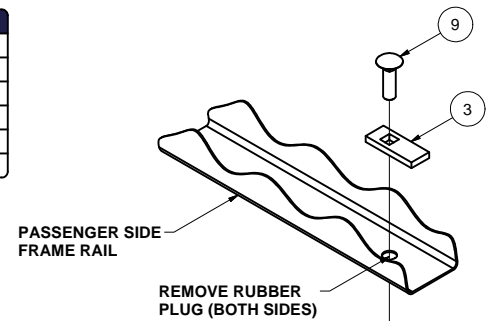
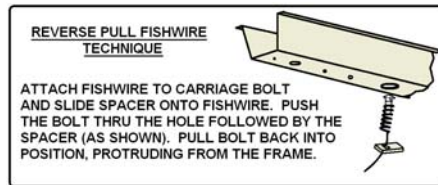
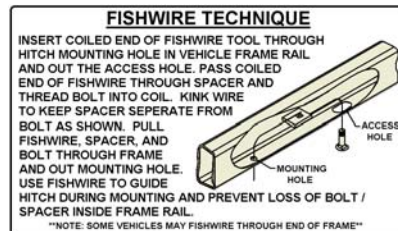

HITCH WEIGHT: 35 LBS.

INSTALL TIME

PROFESSIONAL: 30 MINUTES

NOVICE (DIY): 60 MINUTES

INSTALL NOTES:

- **DRILLING REQUIRED**
- FISHWIRE HARDWARE
- REMOVE RUBBER PLUGS

****Note: Hyundai Accent sedan does not require drilling.****

INSTALLATION STEPS

1. If present, remove rubber plugs from frame holes and return to owner.
2. Raise hitch into position with the tow loop mounting tab resting on top of the tow hook. If not present, mark the forward hole on the driver side frame rail and drill with a 15/32" drill bit. Remove hitch. **Note:** Hyundai Accent sedan does not require drilling.
3. Fishwire (1) 7/16" carriage bolt and (1) CM-SP2 spacer through the access hole into the forward hole on the driver side. Reverse Fishwire (1) 7/16" carriage bolt and (1) CM-SP2 spacer into the access hole on each side. Refer to "Reverse Pull Fishwire Technique & Fishwire Technique" as shown above. **Note:** The access hole location will vary in depending on vehicle model.
4. Raise the hitch back into position. Be careful not to push the carriage bolts back into the frame. Loosely install (4) 7/16" hex flange nuts.
5. Install the remaining 3/8" hardware with (1) CM-SP34 spacer onto the vehicle tow loop, as shown above.
6. Torque all 3/8" fasteners to 30 lb-ft and all 7/16" fasteners to 50 lb-ft.

PERIODICALLY CHECK THIS RECEIVER HITCH TO ENSURE THAT ALL FASTENERS ARE TIGHT AND THAT ALL STRUCTURAL COMPONENTS ARE SOUND.

Curt Manufacturing LLC., warrants this product to be free of defects in material and/or workmanship at the time of retail purchase by the original purchaser. If the product is found to be defective, Curt Manufacturing LLC., may repair or replace the product, at their option, when the product is returned, prepaid, with proof of purchase. Alteration to, misuse of, or improper installation of this product voids the warranty. Curt Manufacturing LLC.'s liability is limited to repair or replacement of products found to be defective, and specifically excludes liability for incidental or consequential loss or damage.