

YEARS: 2012-PRESENT

MAKE: VOLKSWAGEN

MODEL: PASSAT

STYLE: SEDAN

WARNING: NEVER EXCEED YOUR VEHICLE MANUFACTURER'S RECOMMENDED TOWING CAPACITY

WEIGHT CARRYING:
TRAILER WEIGHT: 2,000 LBS.
TONGUE WEIGHT: 200 LBS.

INSTALLATION TIME: 30 MIN.
 THE INSTALL TIME LISTED IS FOR PROFESSIONAL INSTALLERS. IF YOU ARE HESITANT TO UNDERTAKE THIS TASK ON YOUR OWN, CONTACT AN AUTHORIZED CURT INSTALLER FOR ADDITIONAL ASSISTANCE.

INSTALLATION TIPS:

- BEFORE YOU BEGIN INSTALLATION, READ ALL INSTRUCTIONS THOROUGHLY.
- TO EASE INSTALLATION, 2 PEOPLE MAY BE REQUIRED.
- USING PROPER TOOLS WILL GREATLY IMPROVE THE QUALITY OF THE INSTALL AND REDUCE THE TIME REQUIRED.



INSTALLATION REQUIRES:

| | | |
|----------------------------|--------------------------|-----------------------|
| RATCHET | TORQUE WRENCH | 3/4" SOCKET |
| 9" SOCKET EXTENSION | 15 TORXBIT SOCKET | ROTARY TOOL |
| TAPE MEASURE | MASKING TAPE | SILICONE CAULK |
| CUT-OFF WHEEL | SAFETY GLASSES | |

LEVEL OF DIFFICULTY: MODERATE

| EASY | MODERATE | CHALLENGING |
|------|---------------------------------|-------------|
| | - NO DRILLING REQUIRED | |
| | - FASCIA TRIMMING REQUIRED | |
| | - REMOVE DRAIN PLUGS | |
| | - TEMPORARILY REMOVE SPARE TIRE | |
| | | |

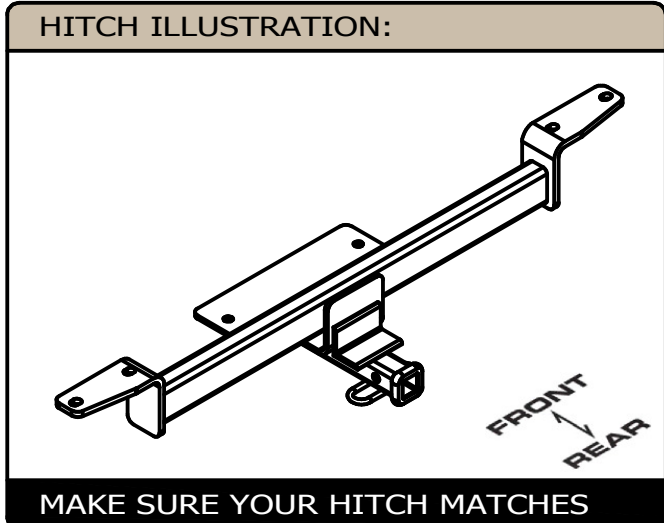

PERIODICALLY CHECK THIS RECEIVER HITCH TO ENSURE ALL FASTENERS ARE TIGHT AND ALL STRUCTURAL COMPONENTS ARE SOUND
 CURT Manufacturing LLC. warrants this product to be free of defects in material and/or workmanship at the time of retail purchase by the original purchaser. If the product is found to be defective, Curt Manufacturing LLC. may repair or replace the product at their option, when the product is returned, prepaid, with proof of purchase. Alteration to, misuse of, or improper installation of this product voids the warranty. Curt Manufacturing LLC.'s liability is limited to repair or replacement of products found to be defective, and specifically excludes liability for incidental or consequential loss or damage.

INSTALLATION WALKTHROUGH:

| Parts List | | | |
|------------|-----|----------------|------------------------|
| ITEM | QTY | PART NUMBER | DESCRIPTION |
| 1 | 4 | 1/2-13 x 5 1/2 | HEX BOLT |
| 2 | 4 | 1/2" | CONICAL TOOTHED WASHER |
| 3 | 2 | 1/2-13 x 1 1/2 | CARRIAGE BOLT |
| 4 | 2 | CM-SP62 | .250" SPACER PLATE |
| 5 | 2 | HFN 1213 | HEX FLANGE NUT |
| 6 | 2 | 11234-NPWA | NUT PLATE WELDMENT |

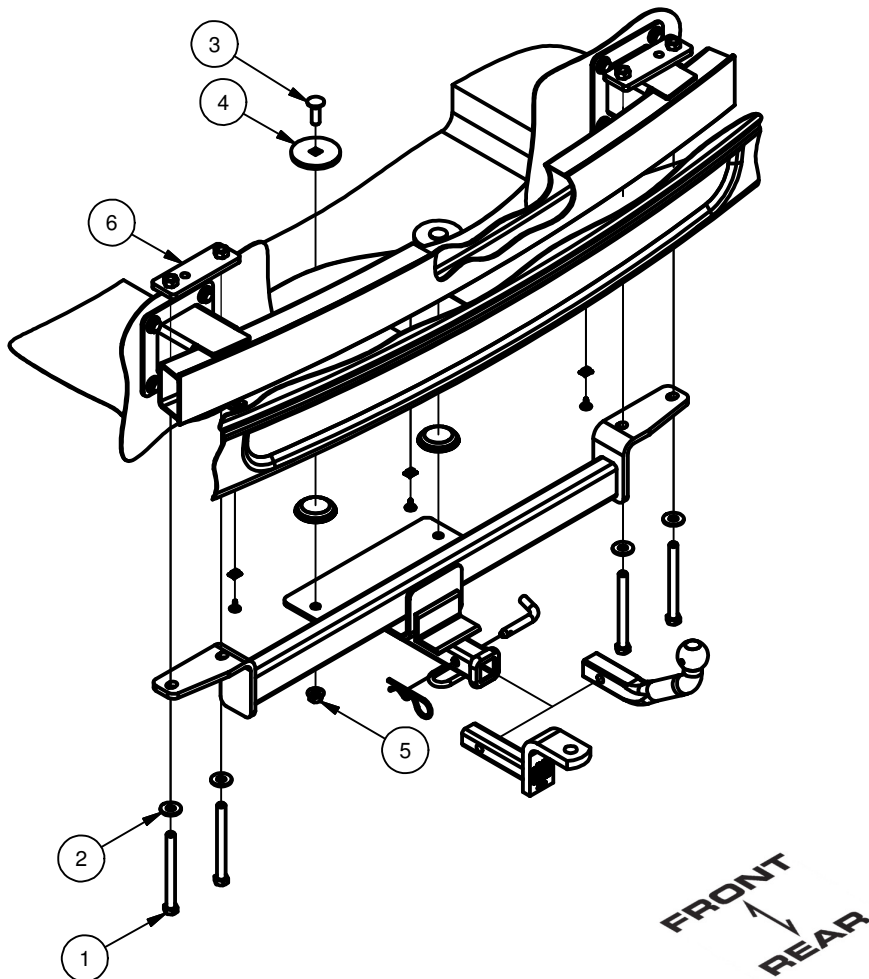

1. Remove the (3) fascia screws and clips holding the rear plastic fascia to the bottom of the trunk pan. Retain (2) screws and clips for reinstallation in Step (9) and return (1) screw and clip to owner.

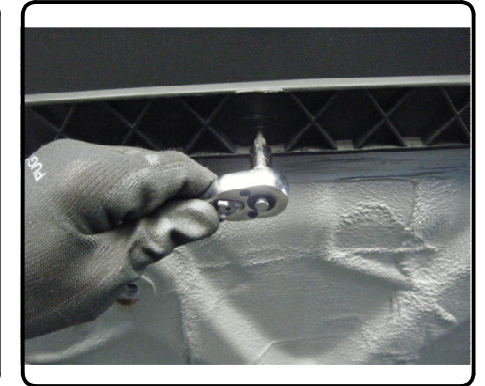
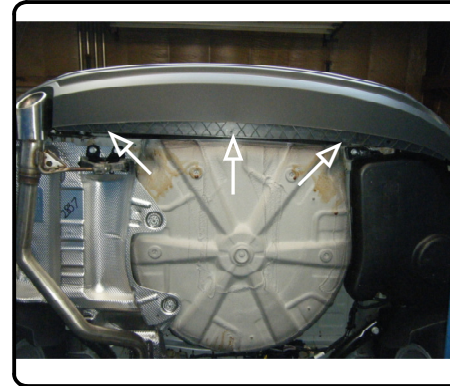

2. Remove the jack and spare tire from inside the trunk.

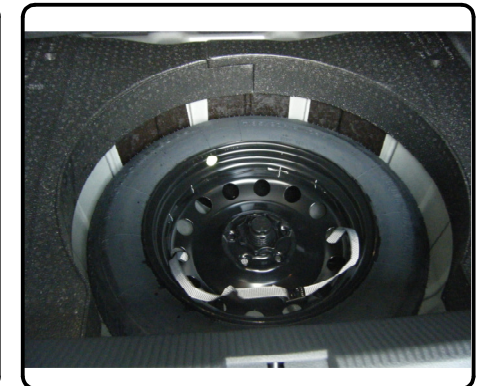
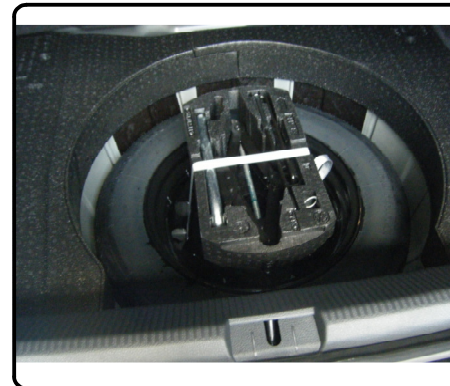

INSTALLATION WALKTHROUGH:

3. Remove the (2) rearmost rubber drain plugs from the bottom of the trunk pan and return to owner.



4. Mark and trim rear fascia. **Note:** Dimensions are approximate, confirm fit prior to trimming.

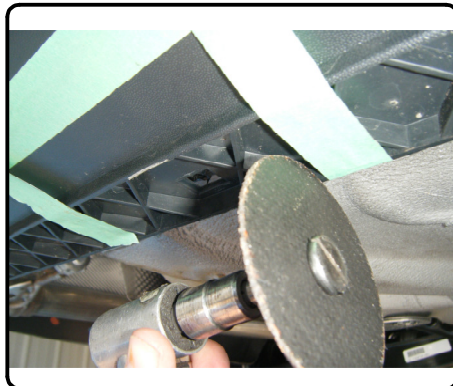
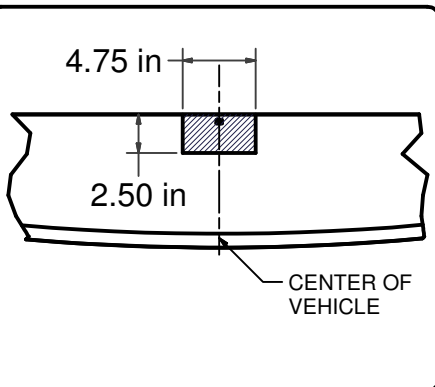

5. Unclip rear fascia on the passenger side. Gently flex the fascia and place nut plates on top of the bumper beam supports.

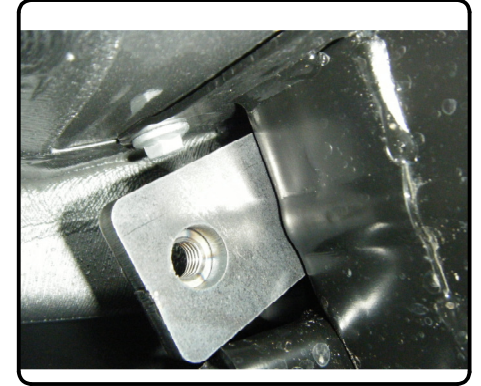

6. Seal around the back two holes on hitch with silicone caulk. Raise hitch into position, aligning the slots in the hitch with the holes in the nut plates.

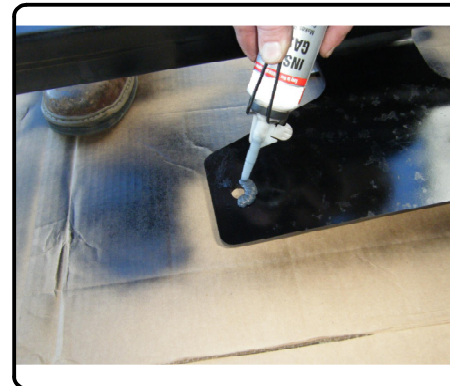

INSTALLATION WALKTHROUGH:

7. Loosely secure the hitch into position using 1/2-13 x 5" hex bolts and 1/2" conical toothed washers. Insert a CM-SP62 spacer and 1/2-13 x 1 1/2" carriage bolt into each of the drain holes and secure from below with 1/2" hex flange nut.



- ↓
8. Torque all 1/2" hardware to 75 ft-lbs. Return the spare tire to the trunk.

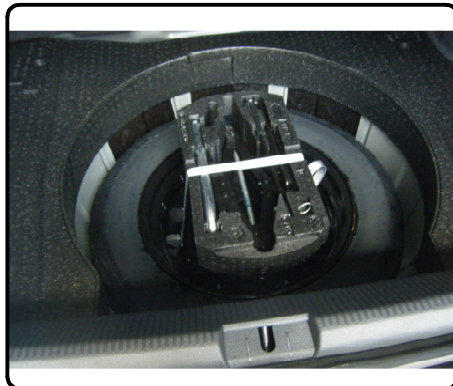
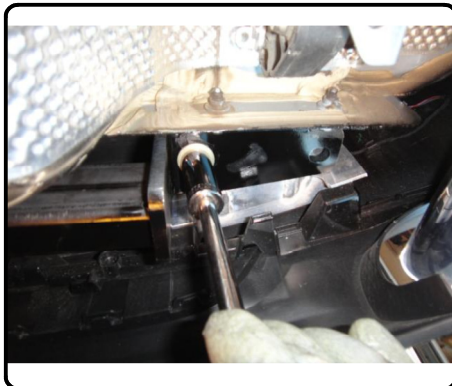

9. Reinstall the (2) outer screws and clips through the bumper fascia and into the trunk pan.



11234

VOLKSWAGEN PASSAT

GROSS LOAD CAPACITY WHEN USED AS A WEIGHT CARRYING HITCH: 2,000 LBS. TRAILER WEIGHT & 200 LBS. TONGUE WEIGHT.

DO NOT EXCEED VEHICLE MANUFACTURER'S RECOMMENDED TOWING CAPACITY.

WARNING: ALL NON-TRAILER LOADS APPLIED TO THIS PRODUCT MUST BE SUPPORTED BY 18050 STABILIZING STRAPS.

** FAILURE TO PROPERLY SUPPORT NON-TRAILER LOADS WILL VOID PRODUCT WARRANTY**

| Parts List | | | |
|------------|-----|----------------|------------------------|
| ITEM | QTY | PART NUMBER | DESCRIPTION |
| 1 | 4 | 1/2-13 x 5 1/2 | HEX BOLT |
| 2 | 4 | 1/2" | CONICAL TOOTHED WASHER |
| 3 | 2 | 1/2-13 x 1 1/2 | CARRIAGE BOLT |
| 4 | 2 | CM-SP62 | .250" SPACER PLATE |
| 5 | 2 | HFN 1213 | HEX FLANGE NUT |
| 6 | 2 | 11234-NPWA | NUT PLATE WELDMENT |

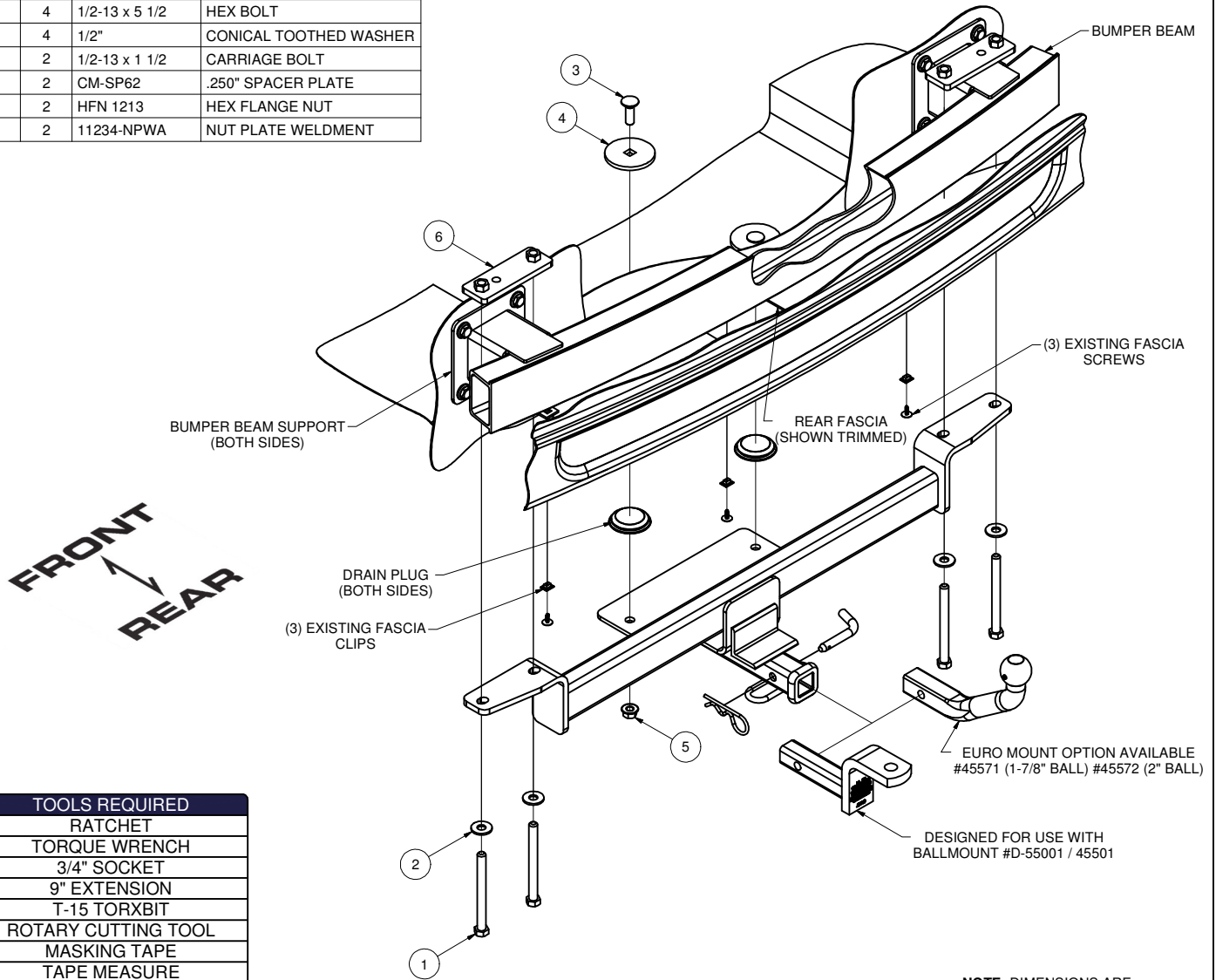

| TOOLS REQUIRED |
|---------------------|
| RATCHET |
| TORQUE WRENCH |
| 3/4" SOCKET |
| 9" EXTENSION |
| T-15 TORXBIT |
| ROTARY CUTTING TOOL |
| MASKING TAPE |
| TAPE MEASURE |
| SILICONE CAULK |
| SAFETY GLASSES |

HITCH WEIGHT: 37 LBS.
 INSTALL TIME
 PROFESSIONAL: 30 MINUTES
 NOVICE (DIY): 60 MINUTES
 INSTALL NOTES:
 - NO DRILLING REQUIRED
 - FASCIA TRIMMING REQUIRED
 - REMOVE PLUGS
 - TEMPORARILY REMOVE SPARE TIRE

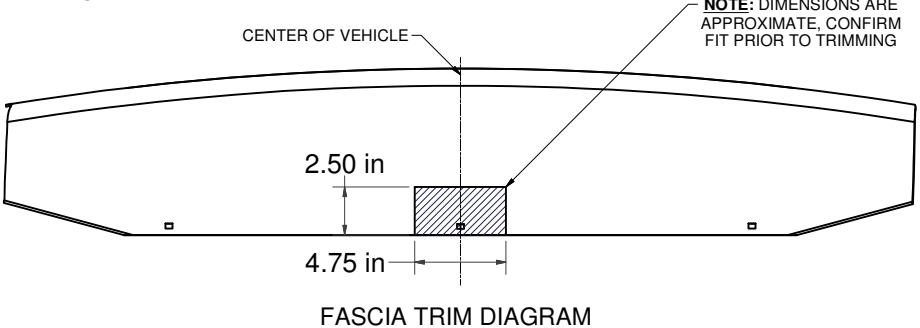

PERIODICALLY CHECK THIS RECEIVER HITCH TO ENSURE THAT ALL FASTENERS ARE TIGHT AND THAT ALL STRUCTURAL COMPONENTS ARE SOUND.

Curt Manufacturing LLC., warrants this product to be free of defects in material and/or workmanship at the time of retail purchase by the original purchaser. If the product is found to be defective, Curt Manufacturing LLC., may repair or replace the product, at their option, when the product is returned, prepaid, with proof of purchase. Alteration to, misuse of, or improper installation of this product voids the warranty. Curt Manufacturing LLC.'s liability is limited to repair or replacement of products found to be defective, and specifically excludes liability for incidental or consequential loss or damage.

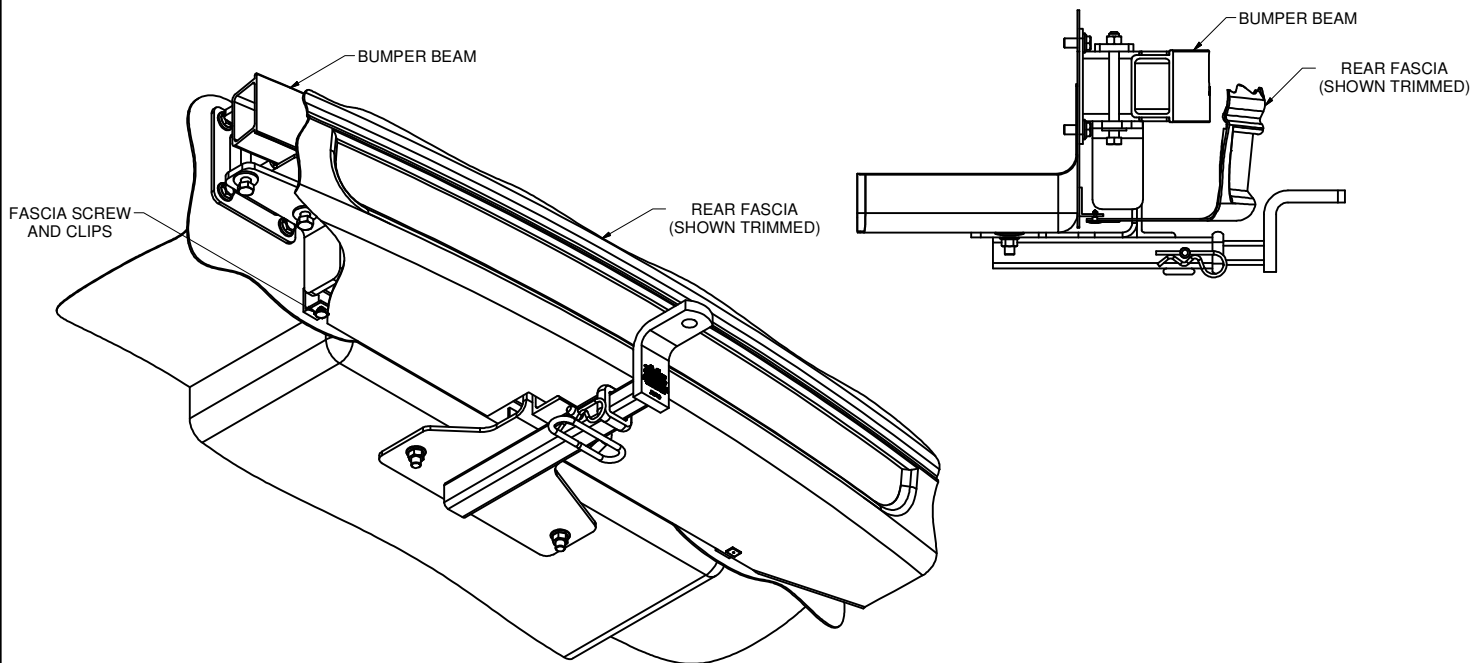

HITCH SHOWN IN PROPER POSITION

INSTALLATION STEPS

1. Remove the (3) fascia screws and clips holding the rear plastic fascia to the bottom of the trunk pan. Retain (2) screws and clips for reinstallation in Step (10) and return (1) screw and clip to owner.
2. Remove the spare tire from inside the trunk.
3. Remove the (2) rearmost rubber drain plugs from the bottom of the trunk pan and return to owner.
4. Mark and trim the rear fascia. **Note:** Dimensions are approximate, confirm fit prior to trimming. (See Fascia Trim Diagram)
5. Gently flex the rear fascia and place the nut plates on top of the bumper beam supports.
6. Raise the hitch into position, aligning the slots in the hitch with the holes in the nut plates. Loosely secure the hitch into position using 1/2-13 x 5" hex bolts and 1/2" conical toothed washers.
7. Seal the drain holes in the trunk pan with silicone caulk. Insert a CM-SP62 spacer and 1/2-13 x 1 1/2" carriage bolt into each of the drain holes and secure from below with 1/2" hex flange nuts.
8. Torque all 1/2" hardware to 75 ft-lbs.
9. Return the spare tire to the trunk.
10. Reinstall the (2) outer screws through the bumper fascia and into the trunk pan.

PERIODICALLY CHECK THIS RECEIVER HITCH TO ENSURE THAT ALL FASTENERS ARE TIGHT AND THAT ALL STRUCTURAL COMPONENTS ARE SOUND.

Curt Manufacturing LLC., warrants this product to be free of defects in material and/or workmanship at the time of retail purchase by the original purchaser. If the product is found to be defective, Curt Manufacturing LLC., may repair or replace the product, at their option, when the product is returned, prepaid, with proof of purchase. Alteration to, misuse of, or improper installation of this product voids the warranty. Curt Manufacturing LLC.'s liability is limited to repair or replacement of products found to be defective, and specifically excludes liability for incidental or consequential loss or damage.