

GROSS LOAD CAPACITY WHEN USED AS A WEIGHT CARRYING HITCH: 2,500 LBS. TRAILER WEIGHT & 200 LBS. TONGUE WEIGHT.

DO NOT EXCEED VEHICLE MANUFACTURER'S RECOMMENDED TOWING CAPACITY.

WARNING: ALL NON-TRAILER LOADS APPLIED TO THIS PRODUCT MUST BE SUPPORTED BY AUXILIARY STABILIZING STRAPS.

** FAILURE TO PROPERLY SUPPORT NON-TRAILER LOADS WILL VOID PRODUCT WARRANTY**

Parts List			
ITEM	QTY	PART NUMBER	DESCRIPTION
1	4	M10 - 1.25 x 40 HEX	HEX BOLT
2	6	7/16"	CONICAL TOOTHED WASHER
3	2	7/16-14 x 1 1/2	CARRIAGE BOLT
4	2	7/16-14	HEX NUT
5	2	7_16 FISHWIRE	7/16" FISHWIRE
6	2	CM-SP40	.188 x 1.00 x 3.00" SQUARE HOLE SPACER

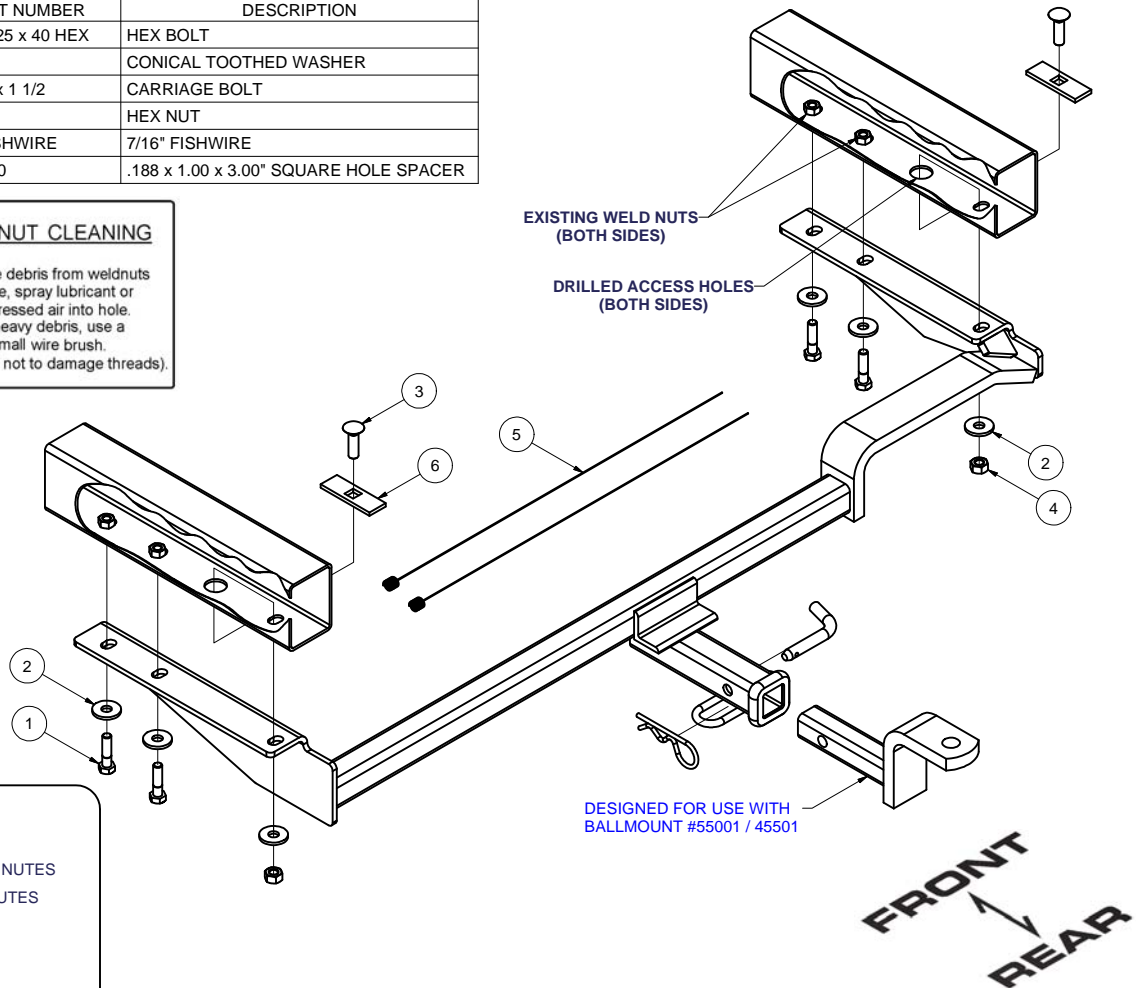
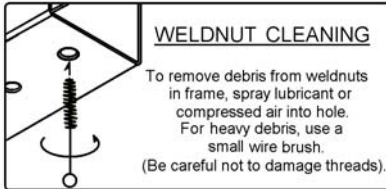

HITCH WEIGHT: 30 LBS.

INSTALL TIME

PROFESSIONAL: 45 MINUTES

NOVICE (DIY): 90 MINUTES

INSTALL NOTES:

- DRILLING REQUIRED
- REMOVE TIE DOWN

INSTALLATION STEPS

1. This hitch will bolt to the bottom of the left and right frame rails at the rear of the car. Remove the tie down brackets from both frame rails (two screws each), and remove a screw fastening the muffler heat shield to the bottom of the right frame rail. Return all parts to the car's owner for reinstallation, should the hitch ever be removed. Hammer the edge of the heat shield flat against the frame rail. The heat shield will be sandwiched between the hitch and the frame.
2. Using a 1 1/4" hole saw, make access holes in the frame rails, located as shown in the diagram, so they will be covered when the hitch is installed. These holes are for fishwiring fasteners into position as shown. These should be installed prior to lifting the hitch into position.
3. Lift the hitch into position being careful not to push the carriage bolts back into the frame. Complete fastener installation as shown.
4. Torque all 10mm fasteners to 36 lb-ft, and all 7/16" fasteners to 50 lb-ft.

PERIODICALLY CHECK THIS RECEIVER HITCH TO ENSURE THAT ALL FASTENERS ARE TIGHT AND THAT ALL STRUCTURAL COMPONENTS ARE SOUND.

Curt Manufacturing Inc., warrants this product to be free of defects in material and/or workmanship at the time of retail purchase by the original purchaser. If the product is found to be defective, Curt Manufacturing Inc., may repair or replace the product, at their option, when the product is returned, prepaid, with proof of purchase. Alteration to, misuse of, or improper installation of this product voids the warranty. Curt Manufacturing Inc.'s liability is limited to repair or replacement of products found to be defective, and specifically excludes liability for incidental or consequential loss or damage.