

GROSS LOAD CAPACITY WHEN USED AS A WEIGHT CARRYING HITCH: 2,000 LBS. TRAILER WEIGHT & 200 LBS. TONGUE WEIGHT.
 DO NOT EXCEED VEHICLE MANUFACTURER'S RECOMMENDED TOWING CAPACITY.

Parts List			
ITEM	QTY	PART NUMBER	DESCRIPTION
1	1	CM-438-FW	7/16" FISHWIRE TOOL
2	1	1/2-13 x 2"	HEX BOLT
3	1	1.2 - 13	NYLOCK HEX NUT
4	2	7/16-14 x 1 1/2	CARRIAGE BOLT
5	2	7/16	WASHER
6	2	7/16	HELICAL LOCK WASHER
7	2	7/16-14	HEX NUT
8	2	CM-SP108	2.00 X 0.88 X .125 SPACER
9	1	CM-SP128	.375 X 1.50" SPACER

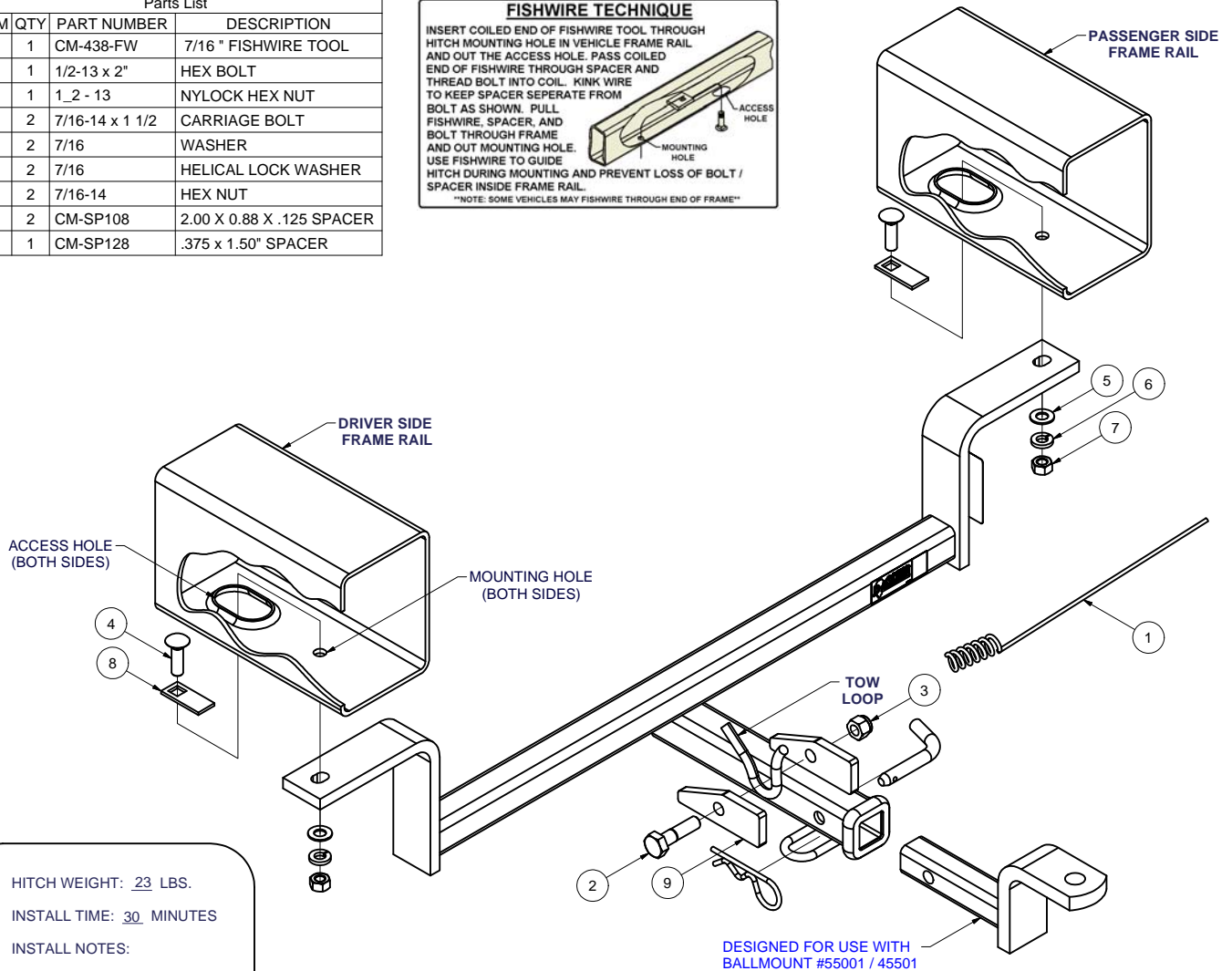
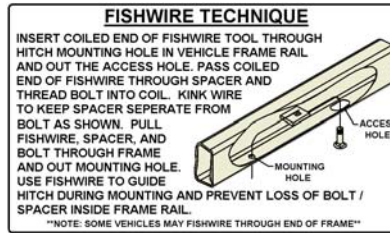

HITCH WEIGHT: 23 LBS.
 INSTALL TIME: 30 MINUTES
 INSTALL NOTES:
NO DRILLING REQUIRED

INSTALLATION STEPS

- 1) General fit: This hitch mounts to the car's central tow loop under the bumper and to existing holes in the left and right frame rails.
- 2) Hold the hitch in position at tow loop and the frame rails to identify the correct frame mounting holes. Fishwire 7/16" carriage bolts with CM-SP108 spacers into position as shown. Use the larger access hole forward of the mounting holes on the bottom of the frame rails.
- 3) Raise hitch to the carriage bolts in the frame rails and install flat washers, lock washers, and hex nuts to each side as shown.
- 4) Use 1/2" fasteners to mount the hitch to the car's tow loop. The larger spacer plate fits to the opposite side of tow loop.
- 5) Torque all 7/16" fasteners to 50 lb-ft, and all 1/2" fasteners to 75 lb-ft

PERIODICALLY CHECK THIS RECEIVER HITCH TO ENSURE THAT ALL FASTENERS ARE TIGHT AND THAT ALL STRUCTURAL COMPONENTS ARE SOUND.

Curt Manufacturing Inc., warrants this product to be free of defects in material and/or workmanship at the time of retail purchase by the original purchaser. If the product is found to be defective, Curt Manufacturing Inc., may repair or replace the product, at their option, when the product is returned, prepaid, with proof of purchase. Alteration to, misuse of, or improper installation of this product voids the warranty. Curt Manufacturing Inc.'s liability is limited to repair or replacement of products found to be defective, and specifically excludes liability for incidental or consequential loss or damage.