

11187

95-00 CHRYSLER SEBRING 4 DOOR (EXCEPT CONVERTIBLE) / 95-02 DODGE AVENGER
 95-02 CHRYSLER SEBRING 2 DOOR (EXCEPT CONVERTIBLE) / 95-02 DODGE STRATUS 2 DOOR ONLY

GROSS LOAD CAPACITY WHEN USED AS A WEIGHT CARRYING HITCH: 2,000 LBS. TRAILER WEIGHT & 200 LBS. TONGUE WEIGHT.

DO NOT EXCEED VEHICLE MANUFACTURER'S RECOMMENDED TOWING CAPACITY.

WARNING: ALL NON-TRAILER LOADS APPLIED TO THIS PRODUCT MUST BE SUPPORTED BY AUXILIARY STABILIZING STRAPS.

** FAILURE TO PROPERLY SUPPORT NON-TRAILER LOADS WILL VOID PRODUCT WARRANTY**

		Parts List	
ITEM	QTY	PART NUMBER	DESCRIPTION
1	1	7/16-14 x 1 1/2	CARRIAGE BOLT
2	1	CM-SP7	.250 x 1.00 x 2.00" SQUARE HOLE SPACER
3	1	7/16-14	LARGE HEX FLANGE NUT
4	1	5/16"	LOCK WASHER
5	1	M8-1.25 x 35	HEX TAP BOLT
6	4	3/8"	CONICAL TOOTHED WASHER
7	4	M10 - 1.25 x 40 HEX	HEX BOLT
8	1	CM-438-FW	7/16 " FISHWIRE TOOL

TOOLS REQUIRED
12mm WRENCH
13, 14, 17 AND 19mm SOCKETS
6" EXTENSION
RATCHET
TORQUE WRENCH

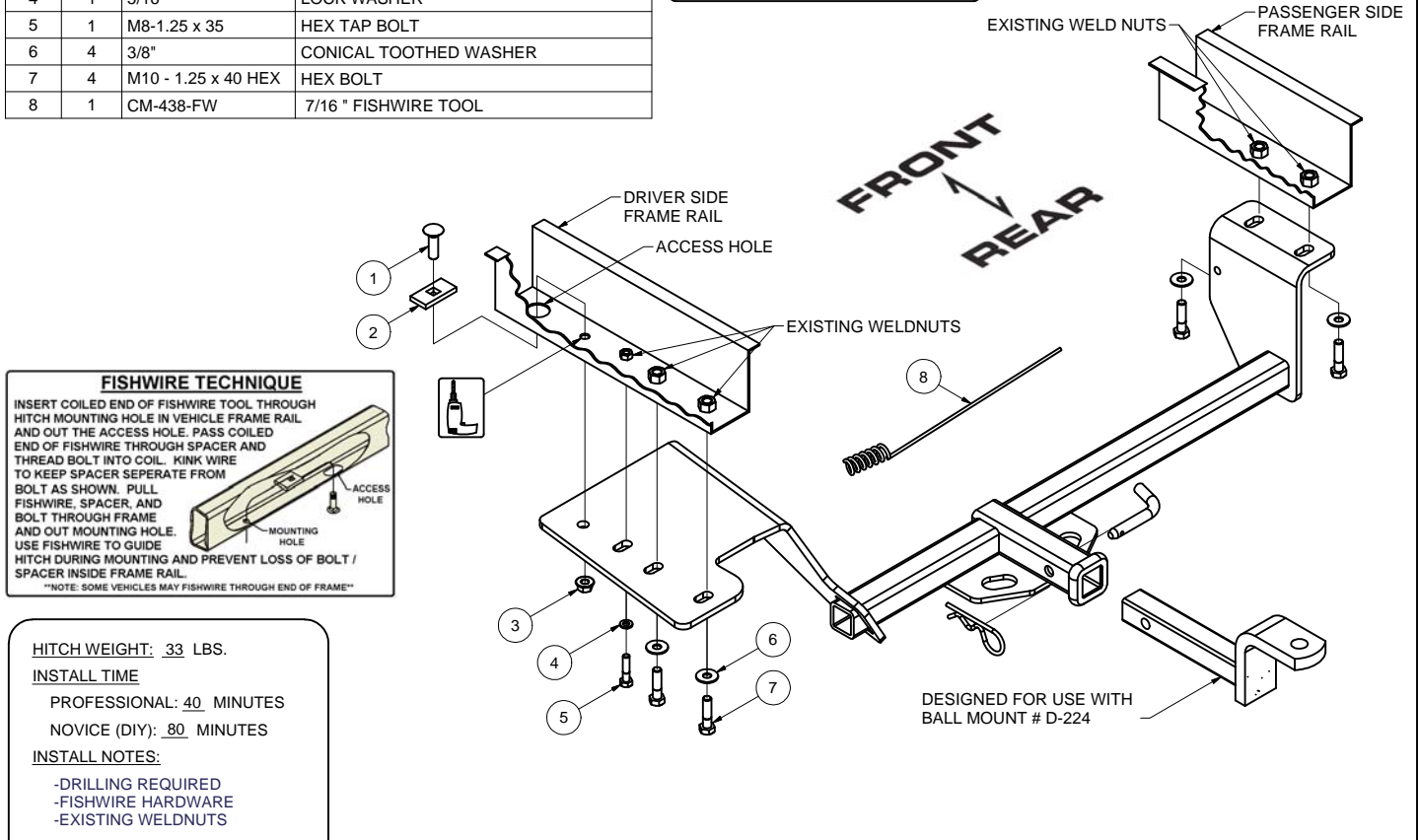

INSTALLATION STEPS

1. Remove muffler and heat shield. Remove four existing M10 bolts from frame rails, two per side.
2. Raise hitch into position and install four M10 bolts (supplied with hitch) as shown. **(Note: Heat shield attachment on the trunk pan will need to be shifted for hitch clearance.)**
3. Using hitch as a template, drill one 1/2" hole for forward attachment as shown.
4. Fishwire 7/16" carriage bolt and spacer through access hole on the frame rail. Secure with 7/16" flange nut.
5. Install M8 fastener into existing weldnut.
6. Reinstall muffler. If existing fasteners are damaged, replace with M10 fasteners provided.
7. Return heat shield, bolts and frame rail bolts to vehicle owner for reinstallation if hitch is removed.
8. Torque M8 fasteners to 25 lb.-ft. Torque M10 fasteners to 38 lb.-ft. Torque 7/16" fasteners to 50 lb.-ft.

PERIODICALLY CHECK THIS RECEIVER HITCH TO ENSURE THAT ALL FASTENERS ARE TIGHT AND THAT ALL STRUCTURAL COMPONENTS ARE SOUND.

Curt Manufacturing Inc., warrants this product to be free of defects in material and/or workmanship at the time of retail purchase by the original purchaser. If the product is found to be defective, Curt Manufacturing Inc., may repair or replace the product, at their option, when the product is returned, prepaid, with proof of purchase. Alteration to, misuse of, or improper installation of this product voids the warranty. Curt Manufacturing Inc.'s liability is limited to repair or replacement of products found to be defective, and specifically excludes liability for incidental or consequential loss or damage.