

11186

AUDI A4 SEDAN

GROSS LOAD CAPACITY WHEN USED AS A WEIGHT CARRYING HITCH: 2,000 LBS. TRAILER WEIGHT & 200 LBS. TONGUE WEIGHT.

DO NOT EXCEED VEHICLE MANUFACTURER'S RECOMMENDED TOWING CAPACITY.

WARNING: ALL NON-TRAILER LOADS APPLIED TO THIS PRODUCT MUST BE SUPPORTED BY AUXILIARY STABILIZING STRAPS.

** FAILURE TO PROPERLY SUPPORT NON-TRAILER LOADS WILL VOID PRODUCT WARRANTY**

Parts List				
ITEM	QTY	PART NUMBER	DESCRIPTION	
1	2	CM-11186-BP	BOLT PLATE	
2	4	1/2-13 x 4 1/2	CARRIAGE BOLT	
3	6	HFN 1213	HEX FLANGE NUT	
4	2	1/2-13 x 1 3/4	CARRIAGE BOLT	
5	2	CM-SP62	.250" SPACER PLATE	

TOOLS REQUIRED
T-25 TORX DRIVER
3/4" SOCKET
SWIVEL EXTENSION
12" EXTENSION
RATCHET
ROTARY CUTTING TOOL
TORQUE WRENCH
SILICONE CAULK

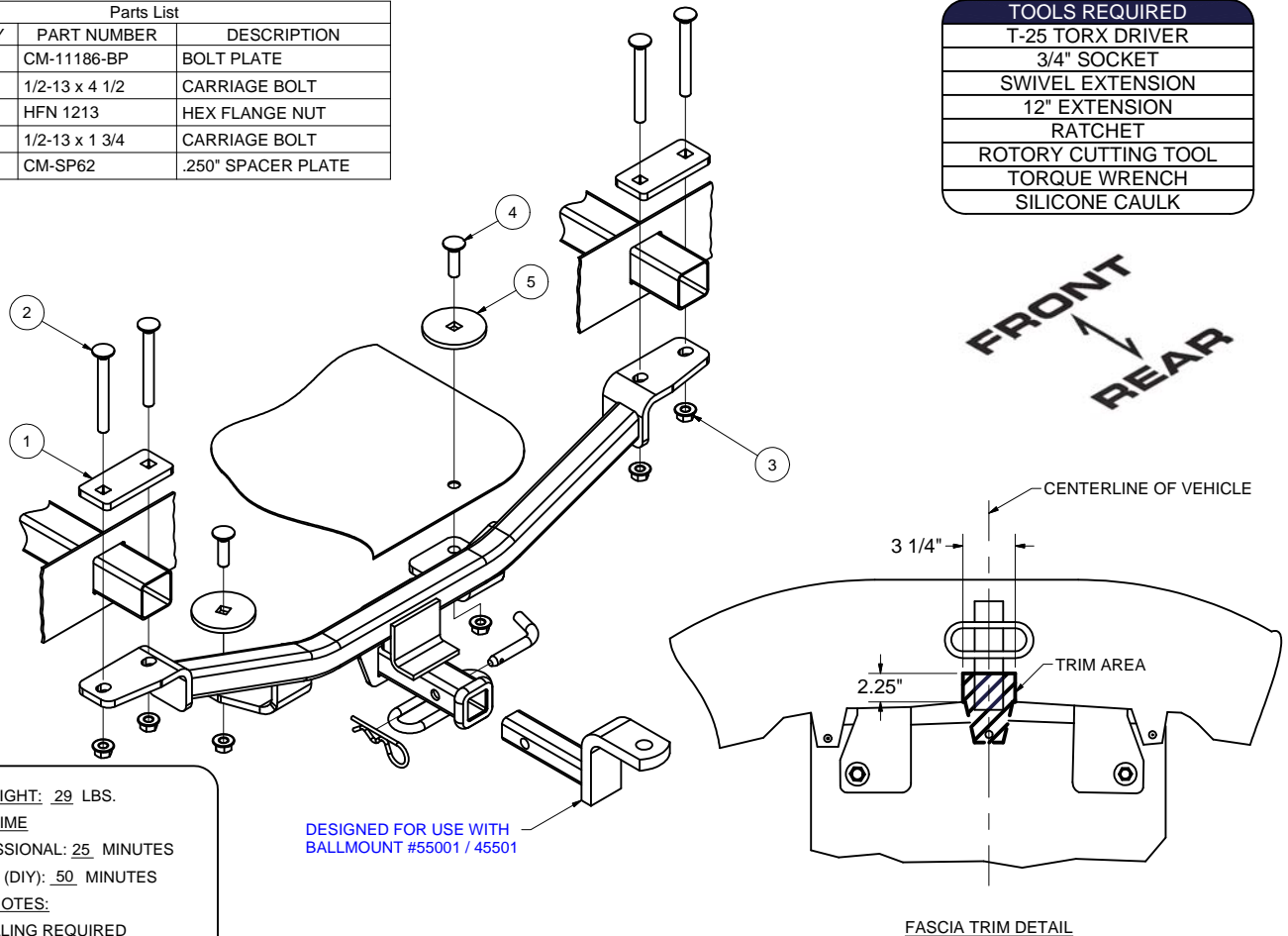

HITCH WEIGHT: .29 LBS.

INSTALL TIME

PROFESSIONAL: .25 MINUTES

NOVICE (DIY): .50 MINUTES

INSTALL NOTES:

-NO DRILLING REQUIRED

-FASCIA TRIMMING REQUIRED

DESIGNED FOR USE WITH
BALLMOUNT #55001 / 45501

INSTALLATION STEPS

- 1) Remove the (3) screws holding the plastic bumper fascia to the bottom of the trunk pan.
- 2) Remove the spare tire and jack from inside the trunk.
- 3) Remove the (2) rearmost plastic drain plugs from the bottom of the trunk pan.
- 4) Using the rotary cutting tool, remove material from the lower part of the plastic fascia as shown in the Fascia Trim Detail above.
- 5) While gently pulling the fascia down and rearward, install the bolt plates and 1/2-13 x 4 1/2 long carriage bolts on top of the bumper support tubes.
- 6) Raise the hitch into position, aligning the slots in the hitch brackets with the long carriage bolts and loosely secure the hitch with hex flange nuts as shown.
- 7) Seal the drain holes in the trunk pan with silicone caulk. Insert a CM-SP-62 spacer and 1/2-13 x 1 3/4 long carriage bolt into each of the drain holes and secure from below with hex flange nuts as shown.
- 8) Torque all 1/2" hardware to 75 ft-lbs.
- 9) Reinstall the two outer screws through the bumper fascia and into the trunk pan.
- 10) Reinstall the jack and spare tire into the trunk.

PERIODICALLY CHECK THIS RECEIVER HITCH TO ENSURE THAT ALL FASTENERS ARE TIGHT AND THAT ALL STRUCTURAL COMPONENTS ARE SOUND.

Curt Manufacturing Inc., warrants this product to be free of defects in material and/or workmanship at the time of retail purchase by the original purchaser. If the product is found to be defective, Curt Manufacturing Inc., may repair or replace the product, at their option, when the product is returned, prepaid, with proof of purchase. Alteration to, misuse of, or improper installation of this product voids the warranty. Curt Manufacturing Inc.'s liability is limited to repair or replacement of products found to be defective, and specifically excludes liability for incidental or consequential loss or damage.