

11138

PONTIAC G8

GROSS LOAD CAPACITY WHEN USED AS A WEIGHT CARRYING HITCH: 2,000 LBS. TRAILER WEIGHT & 200 LBS. TONGUE WEIGHT.

DO NOT EXCEED VEHICLE MANUFACTURER'S RECOMMENDED TOWING CAPACITY.

WARNING: ALL NON-TRAILER LOADS APPLIED TO THIS PRODUCT MUST BE SUPPORTED BY AUXILIARY STABILIZING STRAPS.

** FAILURE TO PROPERLY SUPPORT NON-TRAILER LOADS WILL VOID PRODUCT WARRANTY**

Parts List			
ITEM	QTY	PART NUMBER	DESCRIPTION
1	4	1/2-13 x 1 1/2	CARRIAGE BOLT
2	4	CM-SP4	.250 x 1.50 x 3.00" SQUARE HOLE SPACER
3	4	HFN 1213	HEX FLANGE NUT
4	2	1_2 FISHWIRE	1/2" FISHWIRE

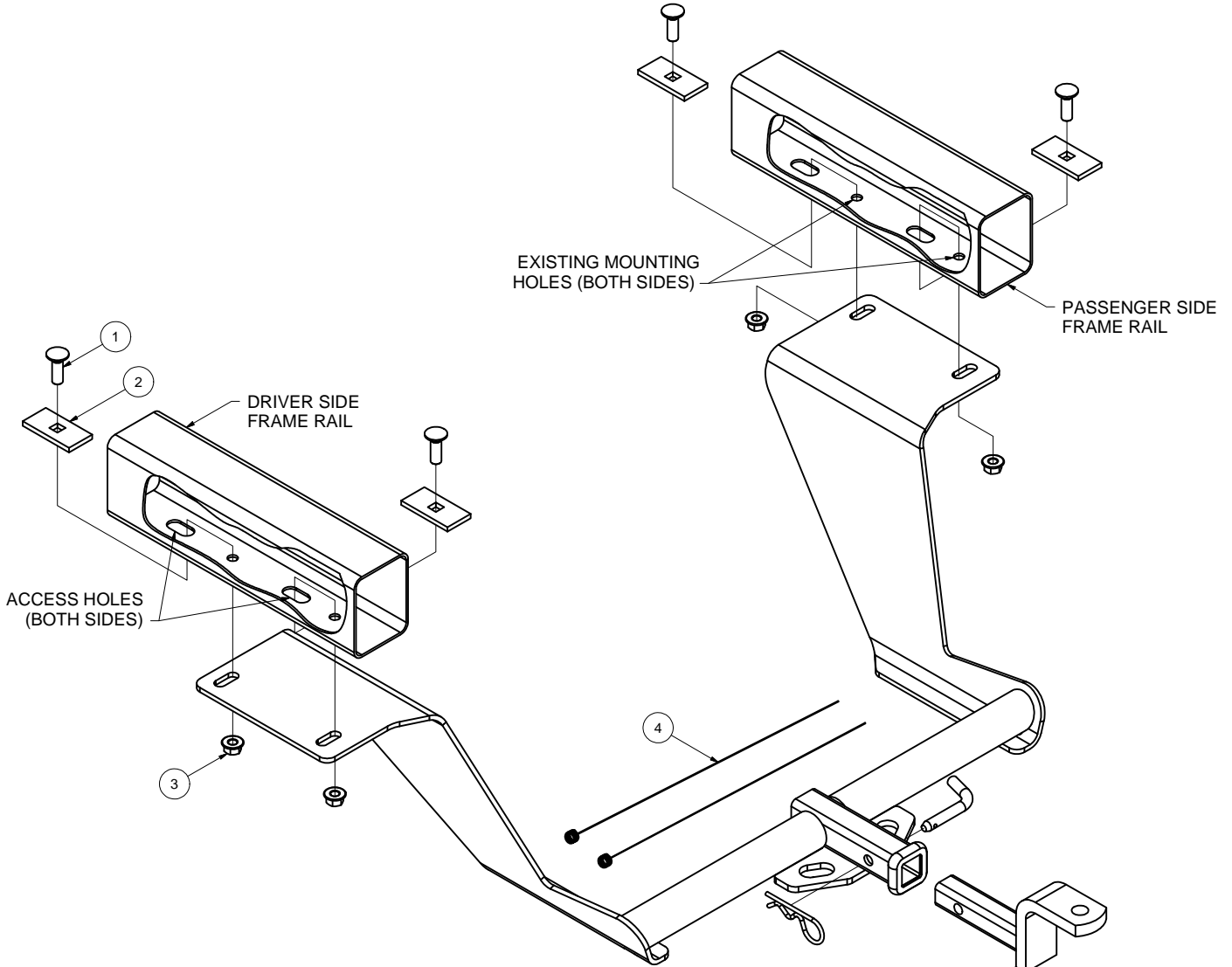

HITCH WEIGHT: .38 LBS.

INSTALL TIME

PROFESSIONAL: 60 MINUTES

NOVICE (DIY): 120 MINUTES

INSTALL NOTES:

- FISHWIRING REQUIRED
- LOWER EXHAUST
- MODIFY HEAT SHIELD
- REMOVE EXHAUST HANGER BRACKET

FRONT
↓
REAR

DESIGNED FOR USE WITH BALLMOUNT #55001 / 45501

PERIODICALLY CHECK THIS RECEIVER HITCH TO ENSURE THAT ALL FASTENERS ARE TIGHT AND THAT ALL STRUCTURAL COMPONENTS ARE SOUND.

Curt Manufacturing Inc., warrants this product to be free of defects in material and/or workmanship at the time of retail purchase by the original purchaser. If the product is found to be defective, Curt Manufacturing Inc., may repair or replace the product, at their option, when the product is returned, prepaid, with proof of purchase. Alteration to, misuse of, or improper installation of this product voids the warranty. Curt Manufacturing Inc.'s liability is limited to repair or replacement of products found to be defective, and specifically excludes liability for incidental or consequential loss or damage.

TOOLS REQUIRED

3/4", 10, 13 & 15mm SOCKETS
10" EXTENSION
RATCHET
TORQUE WRENCH
ROTARY TOOL
CARBIDE BIT
CAR RAMPS

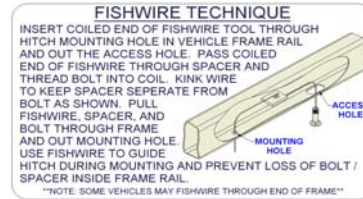
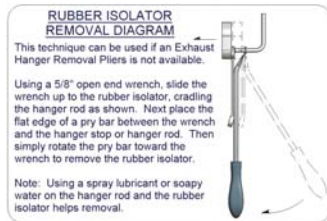
**INSTALLATION STEPS**

Note: The receiver tube must pivot below ground level for hitch installation.

- 1) Lower the exhaust by removing the (2) rubber isolators and the (4) fasteners retaining the rear most isolator bracket mounts. (Refer to rubber isolator removal diagram above.)
- 2) Remove the (4) fasteners retaining the frame crossmember and (8) fasteners retaining the heat shields and lower them. (The frame crossmember straddles the drive shaft tunnel and prevents the exhaust from lowering.)
- 3) Using a screwdriver, puncture the heat shield for the fasteners using the existing holes in the frame as a guide.
- 4) Use the rotary tool and carbide bit as required to enlarge the holes to allow the thread of the 1/2"-13 fasteners to pass through them. Fishwire the 1/2" fasteners and spacers through the large slots in the frame rail. (Refer to fishwire technique diagram above.)
- 5) Reinstall the heat shields, taking care not to push the carriage bolts into the frame rails.
- 6) Raise the hitch over the exhaust and into place. Loosely secure the hitch as shown using the 1/2" flange nuts.
- 7) Torque the all 1/2" fasteners to 75 lb. ft.
- 8) Raise exhaust and reinstall the rubber isolators and crossmember.

PERIODICALLY CHECK THIS RECEIVER HITCH TO ENSURE THAT ALL FASTENERS ARE TIGHT AND THAT ALL STRUCTURAL COMPONENTS ARE SOUND.

Curt Manufacturing Inc., warrants this product to be free of defects in material and/or workmanship at the time of retail purchase by the original purchaser. If the product is found to be defective, Curt Manufacturing Inc., may repair or replace the product, at their option, when the product is returned, prepaid, with proof of purchase. Alteration to, misuse of, or improper installation of this product voids the warranty. Curt Manufacturing Inc.'s liability is limited to repair or replacement of products found to be defective, and specifically excludes liability for incidental or consequential loss or damage.