



# 11073 INSTALLATION INSTRUCTIONS



Safety glasses should be worn at all times while installing this product.

YEARS: 2011-CURRENT

MAKE: MAZDA

MODEL: 2

STYLE: HATCHBACK





**WARNING: NEVER EXCEED YOUR VEHICLE MANUFACTURER'S RECOMMENDED TOWING CAPACITY**

**WEIGHT CARRYING:**  
TRAILER WEIGHT: 1,500 LBS.  
TONGUE WEIGHT: 150 LBS.

**INSTALLATION TIME: 30 MIN.**

THE INSTALL TIME LISTED IS FOR PROFESSIONAL INSTALLERS. IF YOU ARE HESITANT TO UNDERTAKE THIS TASK ON YOUR OWN, CONTACT AN AUTHORIZED CURT INSTALLER FOR ADDITIONAL ASSISTANCE.



### INSTALLATION REQUIRES:

 <b>RATCHET</b>	 <b>TORQUE WRENCH</b>	 <b>9" SOCKET EXTENSION</b>
 <b>10mm 11/16" SOCKET</b>		

### INSTALLATION TIPS:

- BEFORE YOU BEGIN INSTALLATION, READ ALL INSTRUCTIONS THOROUGHLY.
- TO EASE INSTALLATION, 2 PEOPLE MAY BE REQUIRED.
- USING PROPER TOOLS WILL GREATLY IMPROVE THE QUALITY OF THE INSTALL AND REDUCE THE TIME REQUIRED.

### LEVEL OF DIFFICULTY: MODERATE

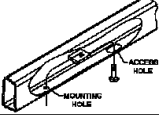
EASY	MODERATE	HARD
	- NO DRILLING REQUIRED	
	- LOWER EXHAUST	
	- FISHWIRE HARDWARE	

### VEHICLE PHOTO:



REPRESENTATIVE PHOTO

### HITCH ILLUSTRATION:

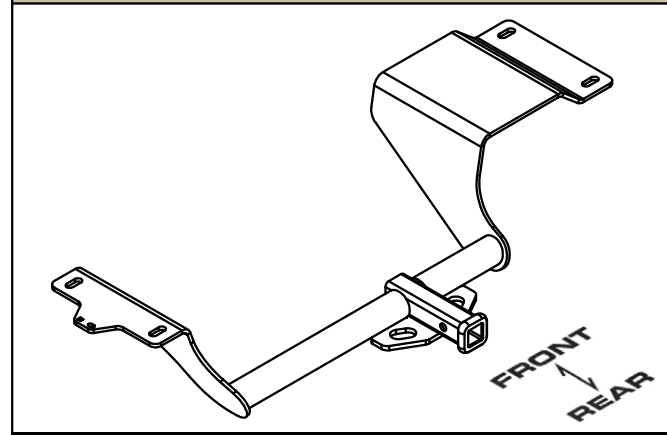

MAKE SURE YOUR HITCH MATCHES

**PERIODICALLY CHECK THIS RECEIVER HITCH TO ENSURE ALL FASTENERS ARE TIGHT AND ALL STRUCTURAL COMPONENTS ARE SOUND**

CURT Manufacturing Inc. warrants this product to be free of defects in material and/or workmanship at the time of retail purchase by the original purchaser. If the product is found to be defective, Curt Manufacturing Inc. may repair or replace the product at their option, when the product is returned, prepaid, with proof of purchase. Alteration to, misuse of, or improper installation of this product voids the warranty. Curt Manufacturing Inc.'s liability is limited to repair or replacement of products found to be defective, and specifically excludes liability for incidental or consequential loss or damage.

## INSTALLATION WALKTHROUGH:

Parts List			
ITEM	QTY	PART NUMBER	DESCRIPTION
1	4	7/16-14	HEX FLANGE NUT
2	1	1/4-20	HEX FLANGE NUT
3	1	1_4 - 20 x 1	CARRIAGE BOLT
4	2	7_16 FISHWIRE	7/16" FISHWIRE
5	4	7/16-14 x 1 1/4	CARRIAGE BOLT
6	4	CM-SP7	.250 x 1.00 x 2.00" SQUARE HOLE SPACER

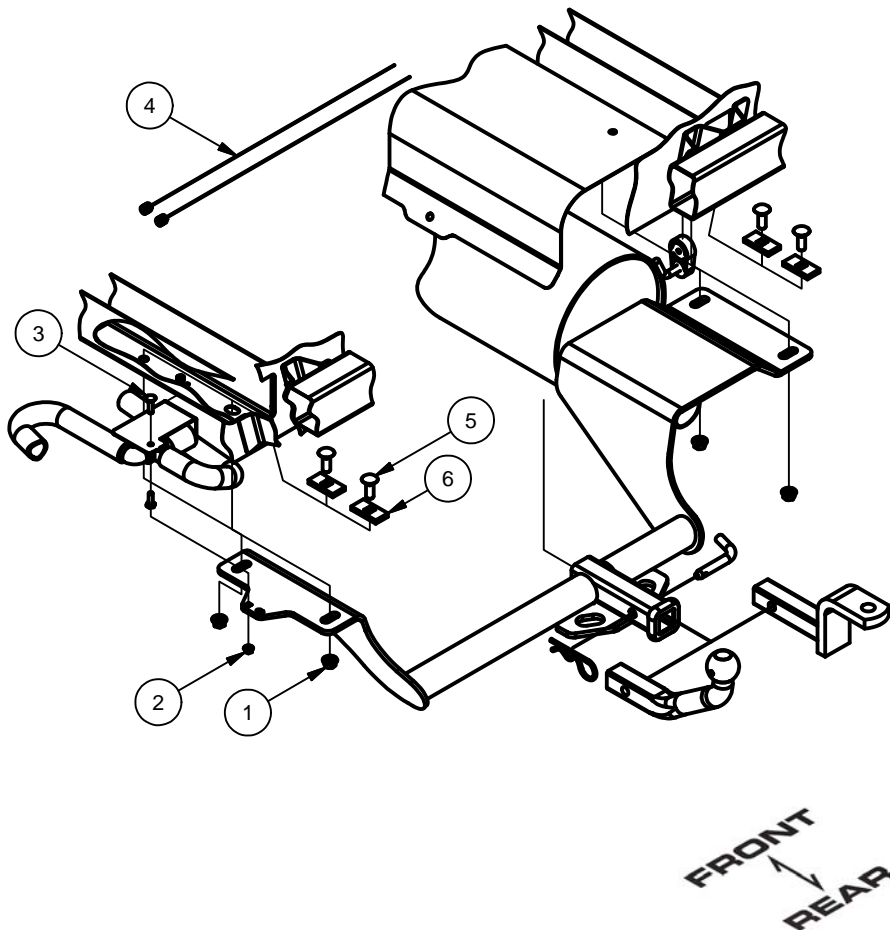

1. Remove the bolt securing the vapor canister to the driver side frame rail and return bolt to owner.

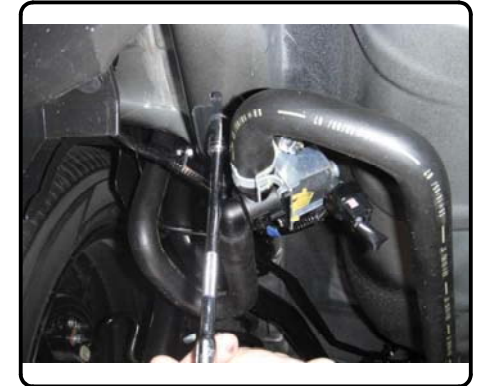

2. Lower exhaust by removing (2) rubber isolators from the hangers attached to the frame.

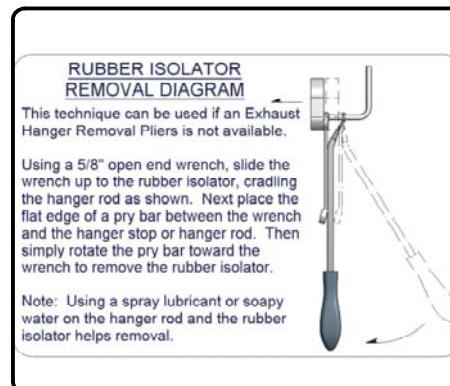

## INSTALLATION WALKTHROUGH:

3. Fishwire 7/16-14 x 1 1/4" carriage bolts and SP7 spacers through the end of the frame rails, both sides. Leave fishwires attached to the passenger side bolts.

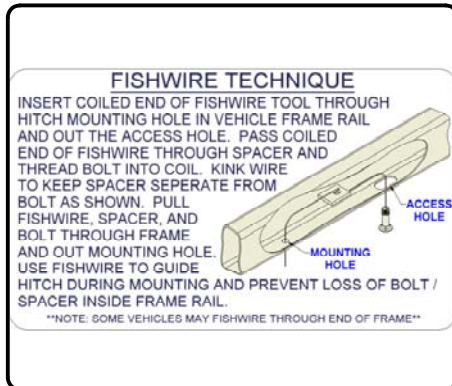

4. Raise passenger side plate over the exhaust and slide it past the exhaust hanger. Raise driver side plate past the vapor canister and secure both plates using 7/16-14 flange nuts.  
**Note:** When raising hitch into position you may have to push bolts part way back into the frame to get the plates into position. You may use fishwires to guide hitch during mounting to prevent the loss of bolts and spacers inside the frame rail.



5. Place the 1/4-20 x 1" carriage bolt through the square hole in the driver side plate. Attach the vapor canister lowered in Step (1) to the carriage bolt and secure with the 1/4-20 flange nut.



6. Torque all 7/16" hardware to 50 ft-lbs.  
Torque all 1/4" hardware to 8 ft-lbs.  
Raise exhaust back into position.  
Installation is now complete.



11073

MAZDA 2

GROSS LOAD CAPACITY WHEN USED AS A WEIGHT CARRYING HITCH: 1,500 LBS. TRAILER WEIGHT & 150 LBS. TONGUE WEIGHT.

\*\*\*DO NOT EXCEED VEHICLE MANUFACTURER'S RECOMMENDED TOWING CAPACITY.\*\*\*

WARNING: ALL NON-TRAILER LOADS APPLIED TO THIS PRODUCT MUST BE SUPPORTED BY 18050 STABILIZING STRAPS.

\*\* FAILURE TO PROPERLY SUPPORT NON-TRAILER LOADS WILL VOID PRODUCT WARRANTY\*\*

Parts List			
ITEM	QTY	PART NUMBER	DESCRIPTION
1	1	1/4-20	HEX FLANGE NUT
2	4	7/16-14	HEX FLANGE NUT
3	1	1_4 - 20 x 1	CARRIAGE BOLT
4	2	7_16 FISHWIRE	7/16" FISHWIRE
5	4	7/16-14 x 1 1/4	CARRIAGE BOLT
6	4	CM-SP7	.250 x 1.00 x 2.00" SQUARE HOLE SPACER

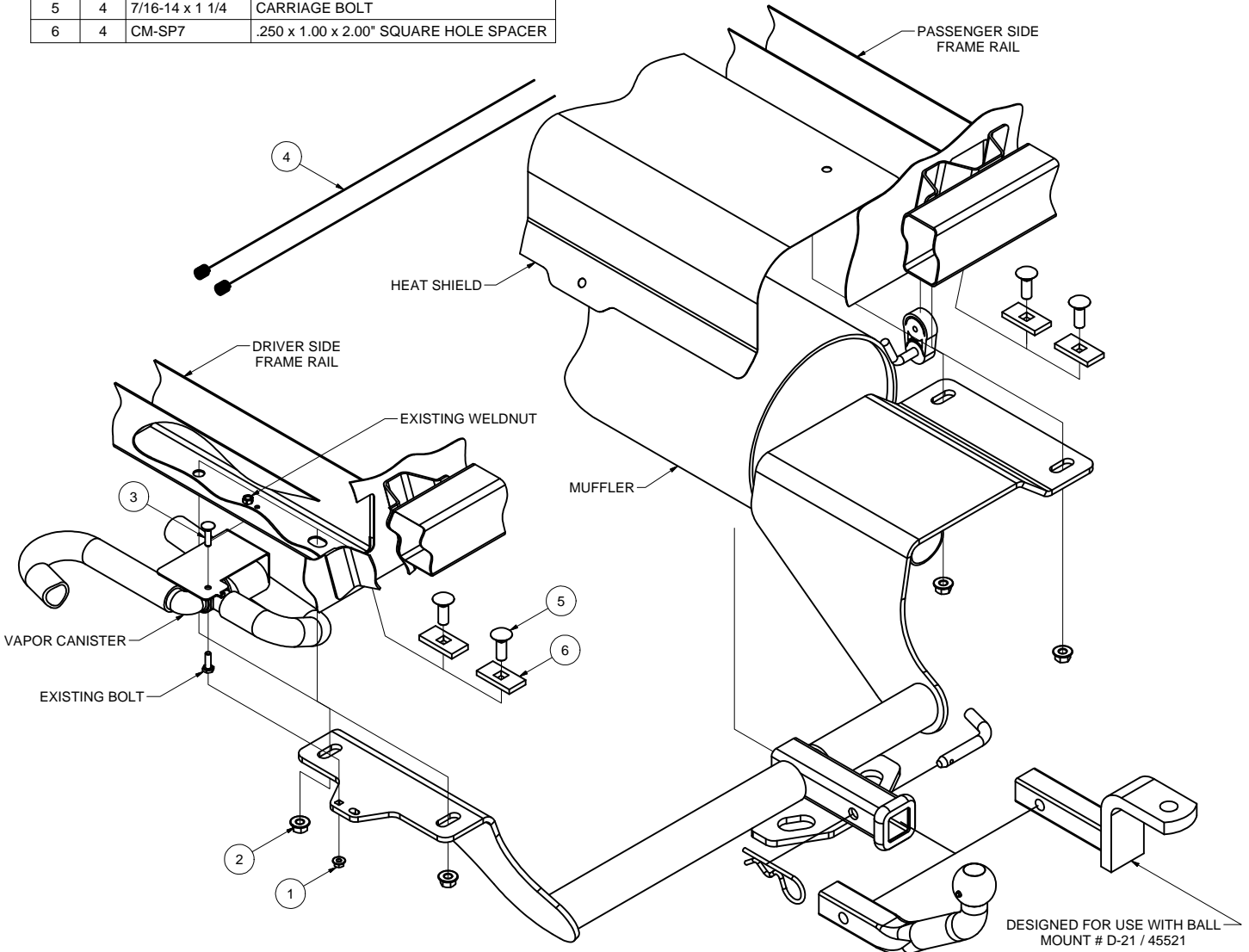

EURO MOUNT OPTION AVAILABLE  
#45571 (1-7/8" BALL) AND #45572 (2" BALL)

HITCH WEIGHT: 34 LBS.

INSTALL TIME

PROFESSIONAL: 30 MINUTES

NOVICE (DIY): 60 MINUTES

INSTALL NOTES:

- NO DRILLING REQUIRED
- LOWER EXHAUST
- FISHWIRE HARDWARE

PERIODICALLY CHECK THIS RECEIVER HITCH TO ENSURE THAT ALL FASTENERS ARE TIGHT AND THAT ALL STRUCTURAL COMPONENTS ARE SOUND.

Curt Manufacturing Inc., warrants this product to be free of defects in material and/or workmanship at the time of retail purchase by the original purchaser. If the product is found to be defective, Curt Manufacturing Inc., may repair or replace the product, at their option, when the product is returned, prepaid, with proof of purchase. Alteration to, misuse of, or improper installation of this product voids the warranty. Curt Manufacturing Inc.'s liability is limited to repair or replacement of products found to be defective, and specifically excludes liability for incidental or consequential loss or damage.

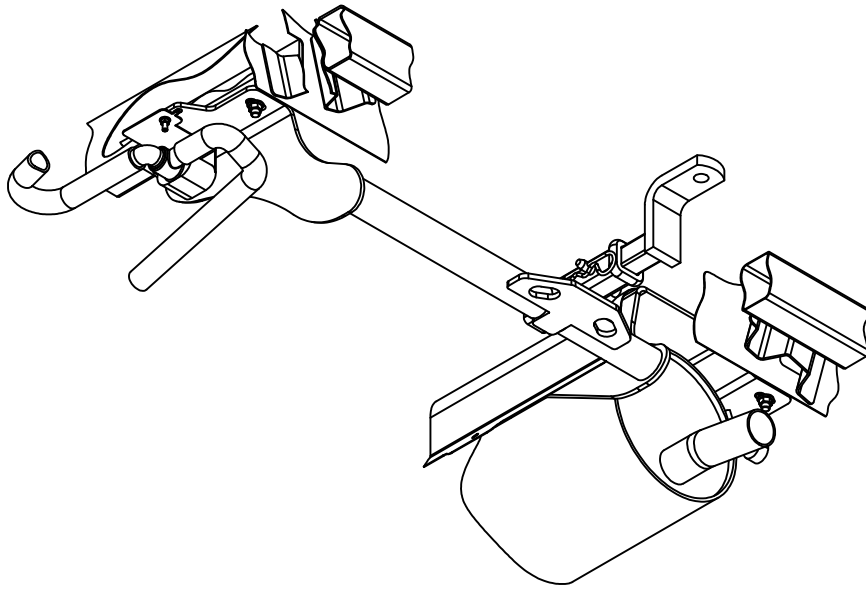

HITCH SHOWN IN PROPER POSITION

**RUBBER ISOLATOR  
REMOVAL DIAGRAM**

This technique can be used if and Exhaust Hanger Removal Pliers is not available.

Using a 5/8" open end wrench, slide the wrench up to the rubber isolator, cradling the hanger rod as shown. Next place the flat edge of a pry bar between the wrench and the hanger stop or hanger rod. Then simply rotate the pry bar toward the wrench to remove the rubber isolator.

Note: Using a spray lubricant or soapy water on the hanger rod and the rubber isolator helps removal.

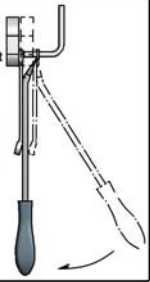
**FISHWIRE TECHNIQUE**

INSERT COILED END OF FISHWIRE TOOL THROUGH HITCH MOUNTING HOLE IN VEHICLE FRAME RAIL AND OUT THE ACCESS HOLE. PASS COILED END OF FISHWIRE THROUGH SPACER AND THREAD BOLT INTO COIL. KINK WIRE TO KEEP SPACER SEPARATE FROM BOLT AS SHOWN. PULL FISHWIRE, SPACER, AND BOLT THROUGH FRAME AND OUT MOUNTING HOLE. USE FISHWIRE TO GUIDE HITCH DURING MOUNTING AND PREVENT LOSS OF BOLT / SPACER INSIDE FRAME RAIL.

\*\*NOTE: SOME VEHICLES MAY FISHWIRE THROUGH END OF FRAME\*\*

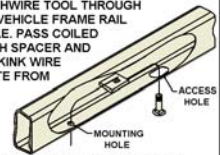
**TOOLS REQUIRED**

RATCHET

TORQUE WRENCH

9" EXTENSION

10mm SOCKET

11/16" SOCKET

**INSTALLATION STEPS**

1. Remove the bolt securing the vapor canister to the driver side frame rail and return bolt to owner.
2. Lower exhaust by removing (2) rubber isolators from the hangers attached to the frame. (See Rubber Isolator Removal Diagram)
3. Fishwire 7/16-14 x 1 1/4" carriage bolts and SP7 spacers through the end of the frame rails, both sides. (See Fishwire Technique) **Note:** Leave fishwires attached to passenger side bolts.
4. Raise passenger side plate over the exhaust and slide it past the exhaust hanger. Raise driver side plate past the vapor canister and secure both plates using 7/16-14 flange nuts. **Note:** When raising hitch into position you may have to push bolts part way back into the frame to get the plates into position. You may use fishwires to guide hitch during mounting to prevent the loss of bolts and spacers inside the frame rail.
5. Place the 1/4-20 x 1" carriage bolt through the square hole in the driver side plate.
6. Attach the vapor canister lowered in Step (1) to the 1/4" carriage bolt and secure with 1/4-20 flange nut.
7. Torque all 7/16" hardware to 50 ft-lbs. Torque all 1/4" hardware to 8 ft-lbs.
8. Raise exhaust back into position.

PERIODICALLY CHECK THIS RECEIVER HITCH TO ENSURE THAT ALL FASTENERS ARE TIGHT AND THAT ALL STRUCTURAL COMPONENTS ARE SOUND.

Curt Manufacturing Inc., warrants this product to be free of defects in material and/or workmanship at the time of retail purchase by the original purchaser. If the product is found to be defective, Curt Manufacturing Inc., may repair or replace the product, at their option, when the product is returned, prepaid, with proof of purchase. Alteration to, misuse of, or improper installation of this product voids the warranty. Curt Manufacturing Inc.'s liability is limited to repair or replacement of products found to be defective, and specifically excludes liability for incidental or consequential loss or damage.