

11028

**06-CURRENT MAZDA MX-5 MIATA CONVERTIBLE
EXCLUDES APPEARANCE PACKAGE**

**GROSS LOAD CAPACITY WHEN USED AS A WEIGHT CARRYING HITCH: 2,000 LBS. TRAILER WEIGHT & 200 LBS. TONGUE WEIGHT.
DO NOT EXCEED VEHICLE MANUFACTURER'S RECOMMENDED TOWING CAPACITY.**

Parts List			
ITEM	QTY	PART NUMBER	DESCRIPTION
1	6	7/16-14 x 1 1/2	CARRIAGE BOLT
2	4	CM-SP2	.250 x .88 x 2.25" SQUARE HOLE SPACER
3	6	7/16-14	HEX FLANGE NUT
4	8	3/8-16 x 1 LG.	CARRIAGE BOLT
5	1	CM-438-FW	7/16" FISHWIRE TOOL
6	8	HFN3816	HEX FLANGE NUT
7	1	CM-11028-DS	.250" DRIVER SIDE PLATE
8	1	CM-11028-PS	.250" PASSENGER SIDE PLATE

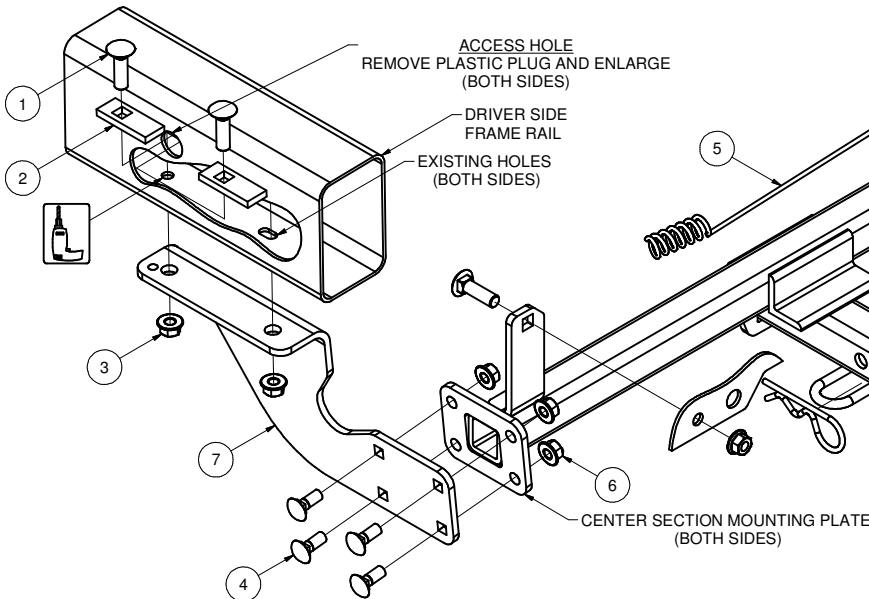
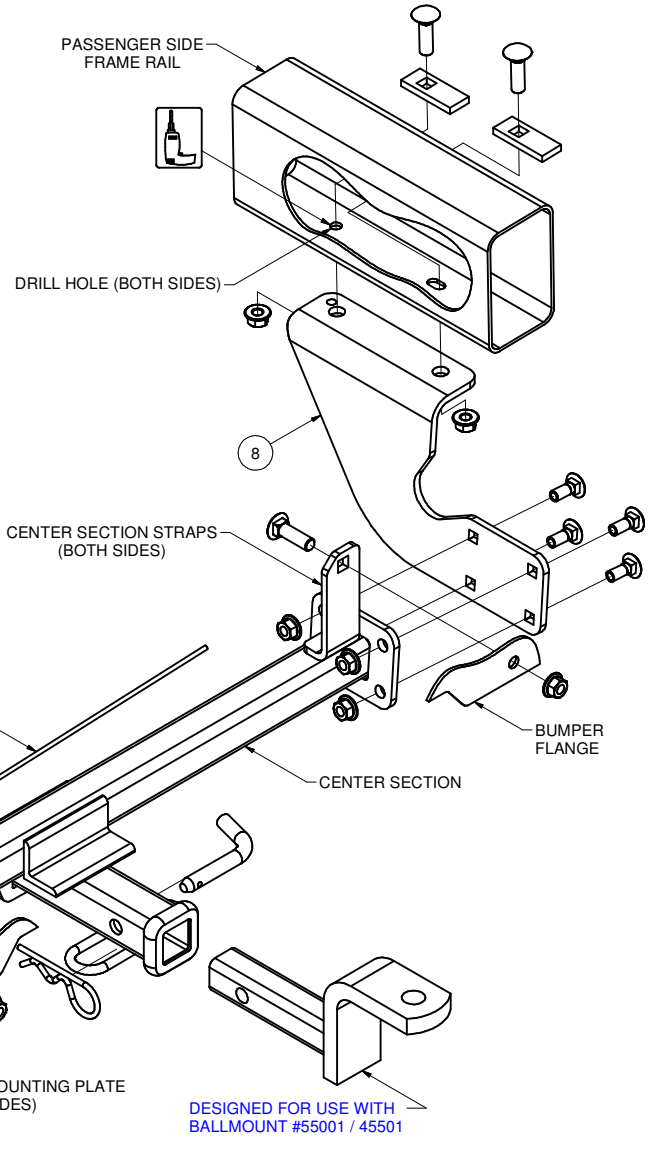
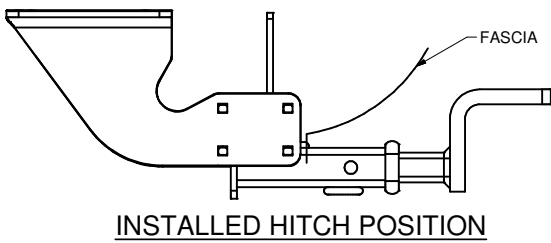

HITCH WEIGHT: 26 LBS.

INSTALL TIME: 90 MINUTES

INSTALL NOTES:

- DRILLING REQUIRED
- FASCIA TRIMMING REQUIRED
- LOWER MUFFLER
- ENLARGE HOLES

**PERIODICALLY CHECK THIS RECEIVER HITCH TO ENSURE THAT ALL FASTENERS
ARE TIGHT AND THAT ALL STRUCTURAL COMPONENTS ARE SOUND.**

Curt Manufacturing Inc., warrants this product to be free of defects in material and/or workmanship at the time of retail purchase by the original purchaser. If the product is found to be defective, Curt Manufacturing Inc., may repair or replace the product, at their option, when the product is returned, prepaid, with proof of purchase. Alteration to, misuse of, or improper installation of this product voids the warranty. Curt Manufacturing Inc.'s liability is limited to repair or replacement of products found to be defective, and specifically excludes liability for incidental or consequential loss or damage.

11028

06-CURRENT MAZDA MX-5 MIATA CONVERTIBLE EXCLUDES APPEARANCE PACKAGE

GROSS LOAD CAPACITY WHEN USED AS A WEIGHT CARRYING HITCH: 2,000 LBS. TRAILER WEIGHT & 200 LBS. TONGUE WEIGHT.
DO NOT EXCEED VEHICLE MANUFACTURER'S RECOMMENDED TOWING CAPACITY.

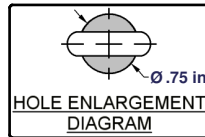
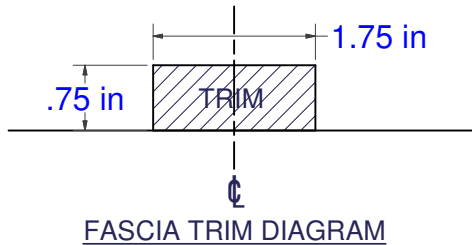

TOOLS REQUIRED
SOCKET WRENCH
9/16" SOCKET
11/16" SOCKET
TORQUE WRENCH
DRILL
7/16" DRILL BIT
ROTARY TOOL
CUTOFF WHEEL

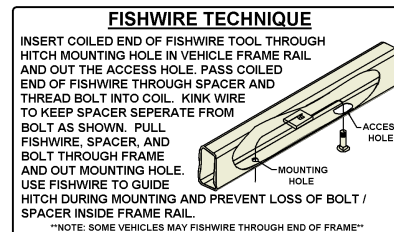
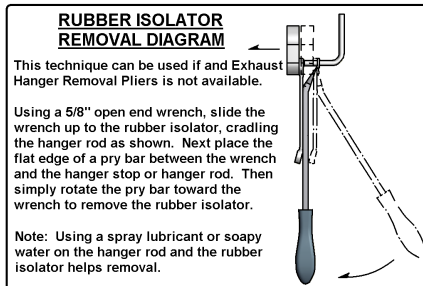

INSTALLATION STEPS

1. Locate center of lower rear fascia, trim a 1 3/4" by 3/4" opening as shown in the Fascia Trim Diagram above.
2. For ease of installation, lower muffler by removing four (4) rubber isolators.
3. Remove the plastic caps on the outside of each frame rail. Enlarge access holes to allow for CM-SP2 spacers and 7/16" carriage bolts to pass through. See HOLE ENLARGEMENT DIAGRAM.
4. Raise center section and securely install 7/16" carriage bolts and nuts through center section straps.
5. Fishwire 7/16" carriage bolts and CM-SP2 spacers through enlarged holes in frame rails and out existing holes as shown.
6. Raise muffler and side plates and secure the side plates to the frame with 7/16" hardware from Step 5 and supplied 7/16" hex flange nuts.
7. Loosely install all eight (8) 3/8" x 1" carriage bolts and nuts through side plates and center section mounting plates as shown.
7. Torque all 3/8" fasteners to 30 lb-ft.
8. Using the hitch as a template, drill remaining holes in frame rails for 7/16" fasteners.
9. Fishwire remaining 7/16" carriage bolts and CM-SP2 spacers through access hole and out drilled holes. Secure hitch with 7/16" hex flange nuts. Reinstall plastic plugs removed in Step 2.
10. Torque all 7/16" fasteners to 50 lb-ft.

**PERIODICALLY CHECK THIS RECEIVER HITCH TO ENSURE THAT ALL FASTENERS
ARE TIGHT AND THAT ALL STRUCTURAL COMPONENTS ARE SOUND.**

Curt Manufacturing Inc., warrants this product to be free of defects in material and/or workmanship at the time of retail purchase by the original purchaser. If the product is found to be defective, Curt Manufacturing Inc., may repair or replace the product, at their option, when the product is returned, prepaid, with proof of purchase. Alteration to, misuse of, or improper installation of this product voids the warranty. Curt Manufacturing Inc.'s liability is limited to repair or replacement of products found to be defective, and specifically excludes liability for incidental or consequential loss or damage.