



# 11001 INSTALLATION INSTRUCTIONS



Safety glasses should be worn at all times while installing this product.

YEARS: 2010-CURRENT

MAKE: MERCEDES-BENZ

MODEL: E-350 SEDAN

STYLE: SEDAN

**WARNING: NEVER EXCEED YOUR VEHICLE MANUFACTURER'S RECOMMENDED TOWING CAPACITY**

**WEIGHT CARRYING:**  
TRAILER WEIGHT: 2,000 LBS.  
TONGUE WEIGHT: 200 LBS.

**INSTALLATION TIME: 30 MIN.**

THE INSTALL TIME LISTED IS FOR PROFESSIONAL INSTALLERS. IF YOU ARE HESITANT TO UNDERTAKE THIS TASK ON YOUR OWN, CONTACT AN AUTHORIZED CURT INSTALLER FOR ADDITIONAL ASSISTANCE.

### INSTALLATION REQUIRES:

 <b>RATCHET</b>	 <b>TORQUE WRENCH</b>	 <b>9" SOCKET EXTENSION</b>
 <b>3/4" SOCKET</b>	 <b>POWER DRILL</b>	 <b>DRILL BIT 17/32"</b>
 <b>CENTER PUNCH</b>	 <b>MASKING TAPE</b>	

### INSTALLATION TIPS:

- BEFORE YOU BEGIN INSTALLATION, READ ALL INSTRUCTIONS THOROUGHLY.
- TO EASE INSTALLATION, 2 PEOPLE MAY BE REQUIRED.
- USING PROPER TOOLS WILL GREATLY IMPROVE THE QUALITY OF THE INSTALL AND REDUCE THE TIME REQUIRED.

### LEVEL OF DIFFICULTY: MODERATE

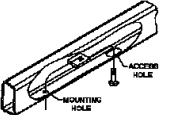
<b>EASY</b>	<b>MODERATE</b>	<b>HARD</b>
	DRILLING REQUIRED	
	FISHWIRE REQUIRED	

### VEHICLE PHOTO:



REPRESENTATIVE PHOTO

### HITCH ILLUSTRATION:

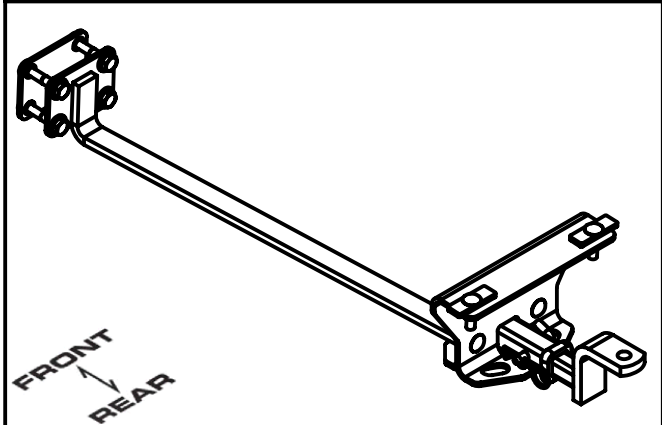

MAKE SURE YOUR HITCH MATCHES

**PERIODICALLY CHECK THIS RECEIVER HITCH TO ENSURE ALL FASTENERS ARE TIGHT AND ALL STRUCTURAL COMPONENTS ARE SOUND**

CURT Manufacturing Inc. warrants this product to be free of defects in material and/or workmanship at the time of retail purchase by the original purchaser. If the product is found to be defective, Curt Manufacturing Inc. may repair or replace the product at their option, when the product is returned, prepaid, with proof of purchase. Alteration to, misuse of, or improper installation of this product voids the warranty. Curt Manufacturing Inc.'s liability is limited to repair or replacement of products found to be defective, and specifically excludes liability for incidental or consequential loss or damage.

## INSTALLATION WALKTHROUGH:

Parts List			
ITEM	QTY	PART NUMBER	DESCRIPTION
1	2	1/2-13 x 1 1/4	CARRIAGE BOLT
2	4	HFN 1213	HEX FLANGE NUT
3	4	1/2 - 13 x 2 1/2	HEX BOLT
4	4	1/2"	CONICAL TOOTHED WASHER
5	2	1_2 FISHWIRE	1/2" FISHWIRE
6	2	1/2 - 13 x 2"	CARRIAGE BOLT
7	2	CM-SP6	.250 x 1.00 x 3.00" SQUARE HOLE SPACER

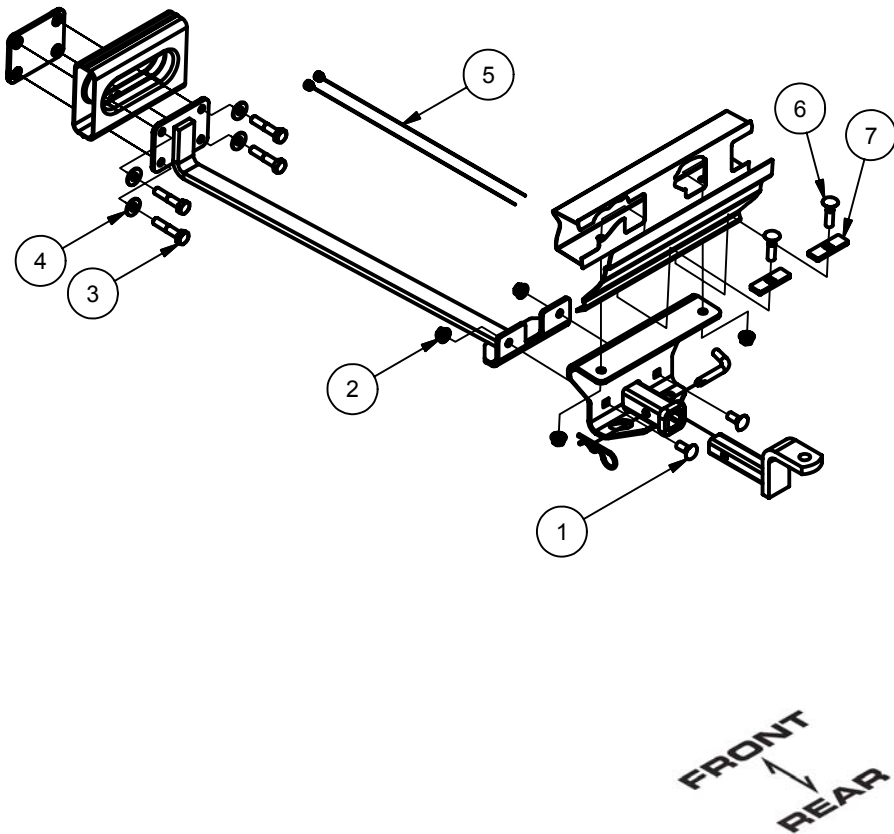

1. Raise nut plate and mounting strap into position around the vehicle crossmember. Secure using 1/2-13 x 2 1/2" hex bolts and 1/2" conical toothed washers.



2. Raise hitch weldment past fascia lip and secure to mounting strap using 1/2-13 x 1 1/4" carriage bolts and 1/2-13 flange nuts.

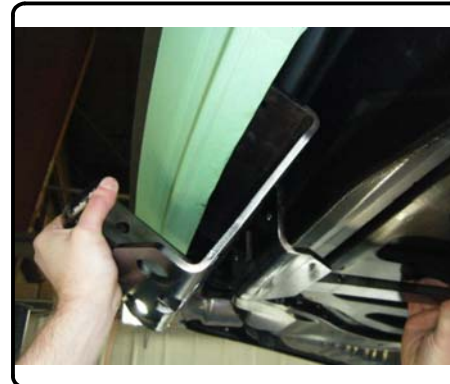

## INSTALLATION WALKTHROUGH:

3. Press hitch against the bottom of the bumper beam, using the hitch as a template mark hole locations with a center punch. Lower hitch and drill hole locations with 17/32" drill bit.

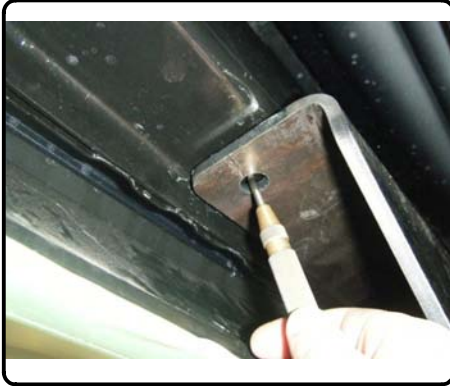

4. Fishwire 1/2-13 x 2" carriage bolt and SP6 spacers through access hole between the fascia and the back of the bumper beam and out the holes drilled in Step 3. Raise hitch back into position and secure with 1/2-13 flange nuts.

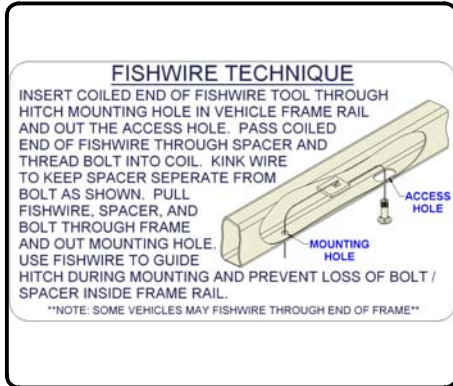

5. Torque all 1/2" fasteners to 75 ft-lbs.



6. Installation is now complete.

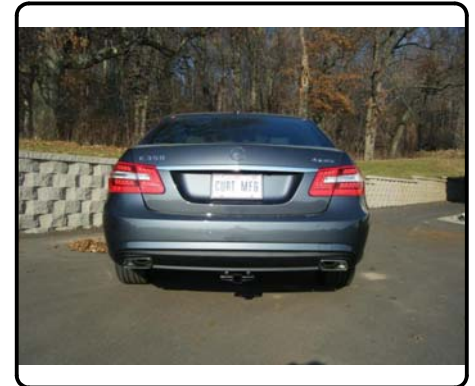

11001

MERCEDES BENZ E-350 SEDAN

GROSS LOAD CAPACITY WHEN USED AS A WEIGHT CARRYING HITCH: 2,000 LBS. TRAILER WEIGHT & 200 LBS. TONGUE WEIGHT.

\*\*\*DO NOT EXCEED VEHICLE MANUFACTURER'S RECOMMENDED TOWING CAPACITY.\*\*\*

WARNING: ALL NON-TRAILER LOADS APPLIED TO THIS PRODUCT MUST BE SUPPORTED BY 18050 STABILIZING STRAPS.

Parts List			
ITEM	QTY	PART NUMBER	DESCRIPTION
1	2	1/2-13 x 1 1/4	CARRIAGE BOLT
2	4	HFN 1213	HEX FLANGE NUT
3	4	1/2 - 13 x 2 1/2	HEX BOLT
4	4	1/2"	CONICAL TOOTHED WASHER
5	2	1_2 FISHWIRE	1/2" FISHWIRE
6	2	1/2 - 13 x 2"	CARRIAGE BOLT
7	2	CM-SP6	.250 x 1.00 x 3.00" SQUARE HOLE SPACER

TOOLS REQUIRED
RATCHET
RATCHET EXTENSION
3/4" SOCKET
DRILL
17/32" DRILL BIT
CENTER PUNCH
TORQUE WRENCH

**FISHWIRE TECHNIQUE**

INSERT COILED END OF FISHWIRE TOOL THROUGH HITCH MOUNTING HOLE IN VEHICLE FRAME RAIL AND OUT THE ACCESS HOLE. PASS COILED END OF FISHWIRE THROUGH SPACER AND THREAD BOLT INTO COIL. KINK WIRE TO KEEP SPACER SEPARATE FROM BOLT AS SHOWN. PULL FISHWIRE, SPACER, AND BOLT THROUGH FRAME AND OUT MOUNTING HOLE. USE FISHWIRE TO GUIDE HITCH DURING MOUNTING AND PREVENT LOSS OF BOLT / SPACER INSIDE FRAME RAIL.

\*\*NOTE: SOME VEHICLES MAY FISHWIRE THROUGH END OF FRAME\*\*

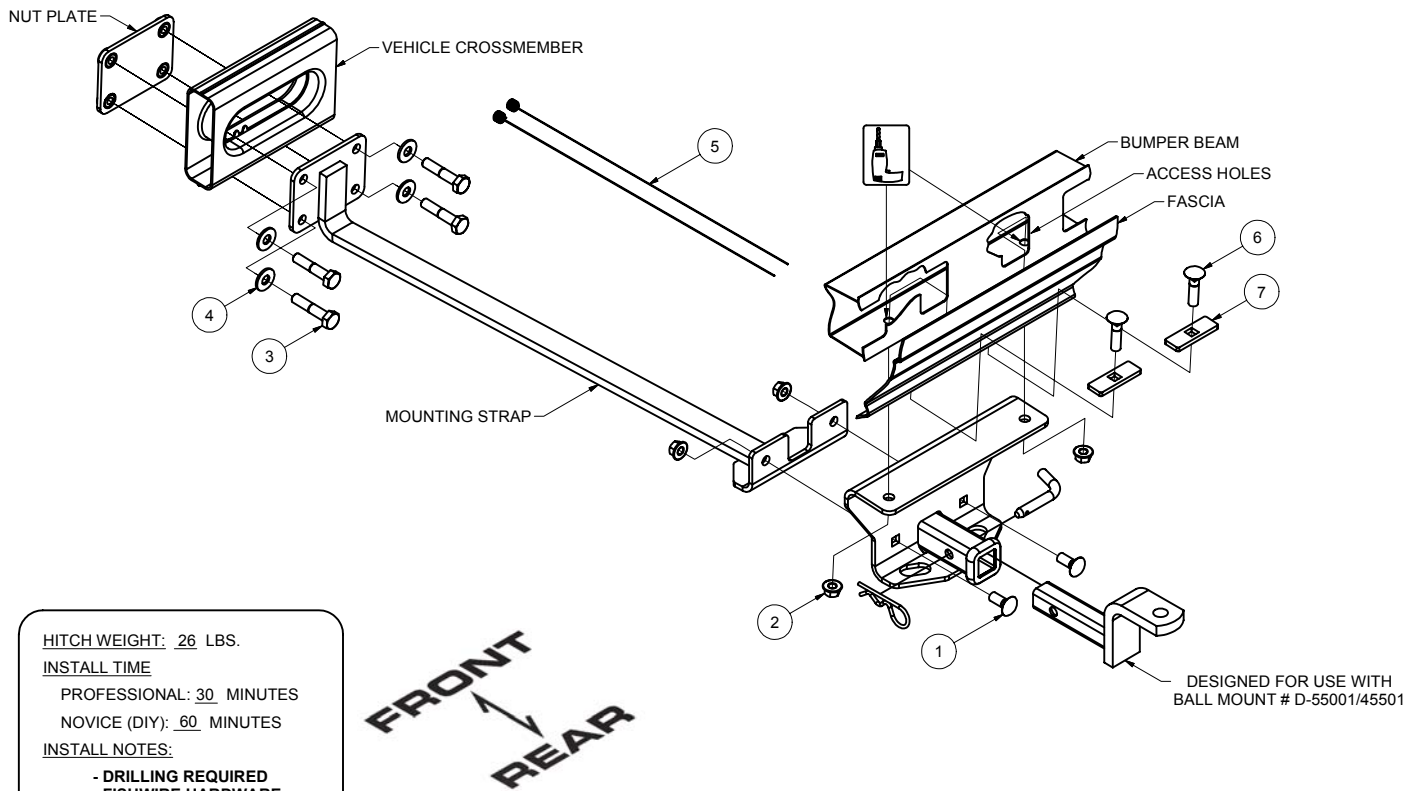

HITCH WEIGHT: 26 LBS.  
 INSTALL TIME  
 PROFESSIONAL: 30 MINUTES  
 NOVICE (DIY): 60 MINUTES  
 INSTALL NOTES:  
 - DRILLING REQUIRED  
 - FISHWIRE HARDWARE

**INSTALLATION STEPS**

1. Raise nut plate and mounting strap into position around the vehicle crossmember. Secure using 1/2-13 x 2 1/2" hex bolts and 1/2" conical toothed washers.
2. Raise hitch weldment past fascia lip and secure to mounting strap using 1/2-13 x 1 1/4" carriage bolts and 1/2-13 flange nuts.
3. Press hitch against the bottom of the bumper beam, using the hitch as a template mark hole locations with a center punch. Lower hitch and drill hole locations with 17/32" drill bit.
4. Fishwire 1/2-13 x 2" carriage bolt and SP6 spacers through the access holes between the fascia and the back of the bumper beam and out the holes drilled in Step 3. Raise hitch back into position and secure with 1/2-13 flange nuts.
5. Torque all 1/2" fasteners to 75 ft-lbs.

**PERIODICALLY CHECK THIS RECEIVER HITCH TO ENSURE THAT ALL FASTENERS ARE TIGHT AND THAT ALL STRUCTURAL COMPONENTS ARE SOUND.**

Curt Manufacturing Inc., warrants this product to be free of defects in material and/or workmanship at the time of retail purchase by the original purchaser. If the product is found to be defective, Curt Manufacturing Inc., may repair or replace the product, at their option, when the product is returned, prepaid, with proof of purchase. Alteration to, misuse of, or improper installation of this product voids the warranty. Curt Manufacturing Inc.'s liability is limited to repair or replacement of products found to be defective, and specifically excludes liability for incidental or consequential loss or damage.