

****DO NOT EXCEED RECOMMENDED VEHICLE TOWING WEIGHT!****

60649 SUBKIT

FORD F-150

WARNING!! BRAKE, FUEL, AND ELECTRICAL LINES MAY NEED TO BE LOOSENED OR REPOSITIONED TO PROVIDE CLEARANCE FOR NEW HARDWARE. SOME MODELS MAY REQUIRE MODIFICATION OR REMOVAL OF HEAT SHIELDS. ON SHORT BED MODELS, CHECK FOR ADEQUATE TURNING CLEARANCE BETWEEN THE FRONT OF ALL TRAILERS AND THE TRUCK CAB. ON TWO WHEEL DRIVE TRUCKS A CLEARANCE CHECK MUST BE PERFORMED WHEN TRUCK IS LOADED AND UNLOADED TO VERIFY THE INVERTED BALL WILL NOT INTERFERE WITH THE TOP OF THE DIFFERENTIAL

PARTS LIST			
ITEM	QTY	PART NUMBER	DESCRIPTION
1	4	5_8 FISHWIRE	5/8" FISHWIRE
2	6	5/8-11	HEX FLANGE NUT
3	6	5/8-11 x 1 3/4, GR8	CARRIAGE BOLT
4	10	1_2 - 13 x 1 1/2 HEX, GR8	HEX BOLT
5	10	1/2	CONICAL TOOTHED WASHER
6	4	HFN 1213, GR8	HEX FLANGE NUT
7	2	CM-SP9	.250 x 1.25 x 2.50" SQUARE HOLE SPACER
8	4	60649-SP	.250" SPACER
21	1	PA4027	SHIPPING BOX (NOT SHOWN)
22	2	PA4026-1	SHIPPING BOX INSERT (NOT SHOWN)
E	1	60910	GOOSENECK GALVANIC ISOLATOR

Hardware			
ITEM	QTY	PART NUMBER	DESCRIPTION
A	1	60649-DSW	DRIVER SIDE WELDMENT
B	1	60649-PSW	PASSENGER SIDE WELDMENT
C	1	60649-FCA	1" x 2" FRONT CROSS ARM
D	1	60649-RCA	2.50 x 2.00 x .375" REAR CROSS ARM
E	1	60910	GOOSENECK GALVANIC ISOLATOR

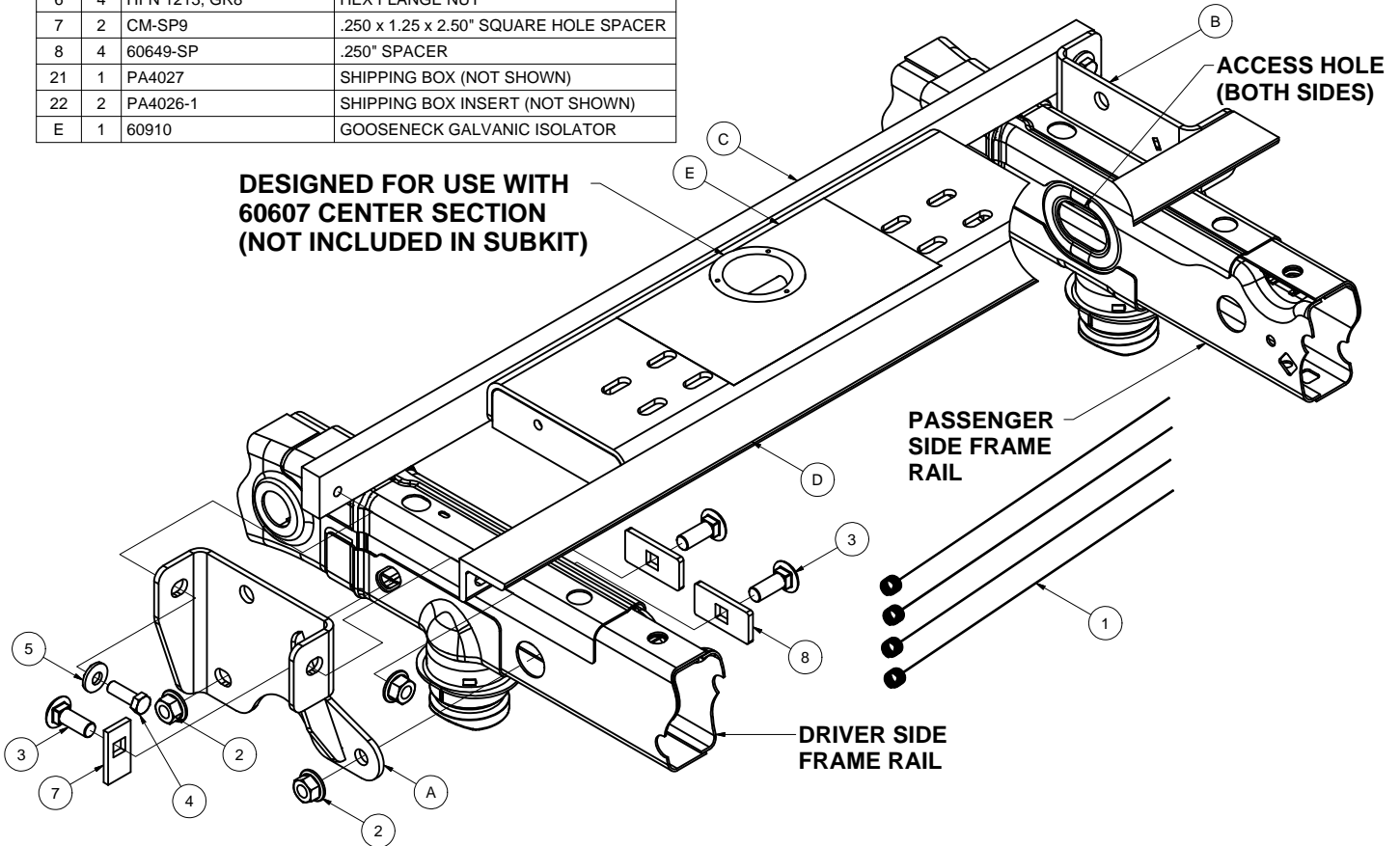

FRONT
↑
REAR

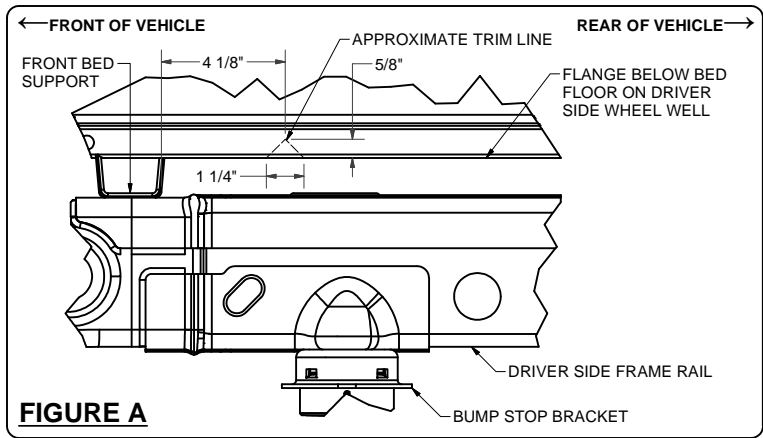

SUBKIT WEIGHT: 57 LBS.
INSTALL TIME
 PROFESSIONAL: 45 MINUTES
 NOVICE (DIY): 90 MINUTES
INSTALL NOTES:
 - NO DRILLING INTO FRAME
 - NO LOWERING EXHAUST
 - FISHWIRING REQUIRED
 - TRIMMING REQUIRED

PERIODICALLY CHECK THIS GOOSENECK HITCH TO ENSURE THAT ALL FASTENERS ARE TIGHT AND THAT ALL STRUCTURAL COMPONENTS ARE SOUND.



****DO NOT EXCEED RECOMMENDED VEHICLE TOWING WEIGHT!****

60649 SUBKIT

FORD F-150

WARNING!! BRAKE, FUEL, AND ELECTRICAL LINES MAY NEED TO BE LOOSENED OR REPOSITIONED TO PROVIDE CLEARANCE FOR NEW HARDWARE. SOME MODELS MAY REQUIRE MODIFICATION OR REMOVAL OF HEAT SHIELDS. ON SHORT BED MODELS, CHECK FOR ADEQUATE TURNING CLEARANCE BETWEEN THE FRONT OF ALL TRAILERS AND THE TRUCK CAB. ON TWO WHEEL DRIVE TRUCKS A CLEARANCE CHECK MUST BE PERFORMED WHEN TRUCK IS LOADED AND UNLOADED TO VERIFY THE INVERTED BALL WILL NOT INTERFERE WITH THE TOP OF THE DIFFERENTIAL

BEFORE INSTALLING

For ease of installation the use of Curt Part # 60606 (Gooseneck Install Tool) is recommended. A lifting device, such as an engine hoist, or cable come-a-long can also be used to lift the center section of the hitch into place. Use of one of these tools will be especially helpful if the truck bed has been distorted downward from heavy use. After the hole is drilled in the truck bed the rope or chain loop can be lowered through the drilled hole and attached to the center of the gooseneck hitch. The gooseneck can then be raised so that the center ring protrudes through the bed floor. Maintaining the upward pressure from the lifting device onto the gooseneck hitch will ease the process of attaching the gooseneck center section to the crossarms. Remove lifting device before torquing hardware.

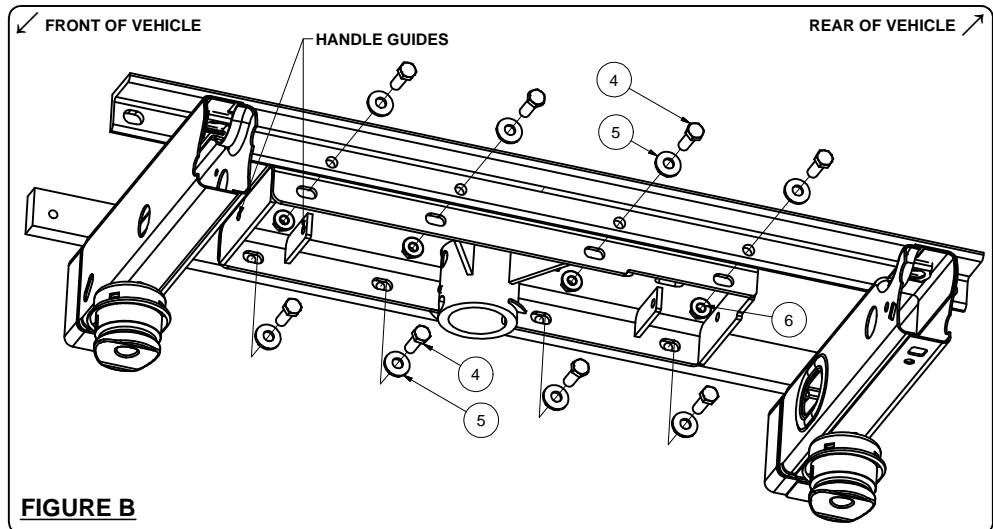

FIGURE B

INSTALLATION STEPS:

1. Mark the location for the hole in the truck bed. Measure from the tail gate end of the truck bed. Do this by hooking a tape measure over the back of the truck box and marking the correct location. (NOTE: DO NOT MEASURE FROM EDGE OF TAILGATE) Next, mark the center between the wheel wells. This marks the center point for the drill hole. This hole location is critical for the correct installation of this hitch. Measure, mark, and saw carefully. This location will put the ball 2" in front of the axle.

BALL CYLINDER MEASUREMENT

5.5' / 6.5' / 8' BED = **43.5"**

(CENTER CYLINDER IN GOOSENECK OFFSET TOWARDS FRONT OF VEHICLE)

**** IMPORTANT NOTE ****

If truck has a spray on bed liner, add 1/8" TO 3/16" when measuring location of center hole.

NOTE: If truck has a plastic bed liner, you may drill through both, but it is more difficult to accurately locate the midpoint between the wells, and to keep the bed liner from moving while cutting the hole. Make a 4" (3 5/8" for the 60640) hole at this location using a 4" (or 3 5/8") hole saw or by making a 4" (or 3 5/8") circle and cutting it out with a saber saw equipped with a metal cutting blade.

2. Temporarily remove spare tire.
3. On the driver side, mark the inner wheel well to notch for cross arm installation and handle operation as shown in **FIGURE A**.
4. Insert cross arms (A) between the truck bed and frame. The cross arms will be inserted from the outside of the truck in front of the rear tire over the low point on the frame. Insert the bar cross arm (C) between the frame and the truck bed, as shown in **FIGURE A**. Once it is partially inserted, guide it the rest of the way from underneath the truck. It will span the frame rails and be behind the front bed support. Slide this cross arm as far forward as possible. Insert the angle cross arm (D) into position using the notch made in step 2. Make sure when the angle cross arm is in position, that the holes are toward the front of the vehicle as shown in **FIGURE B**. Slide the angle toward the rear of the vehicle about 8" to allow room for the gooseneck center and the side plates (A) and (B)

PERIODICALLY CHECK THIS GOOSENECK HITCH TO ENSURE THAT ALL FASTENERS ARE TIGHT AND THAT ALL STRUCTURAL COMPONENTS ARE SOUND.

****DO NOT EXCEED RECOMMENDED VEHICLE TOWING WEIGHT!****

60649 SUBKIT

FORD F-150

WARNING!! BRAKE, FUEL, AND ELECTRICAL LINES MAY NEED TO BE LOOSENED OR REPOSITIONED TO PROVIDE CLEARANCE FOR NEW HARDWARE. ALL MODELS REQUIRE MODIFICATION OR REMOVAL OF HEAT SHIELDS. ON SHORT BED MODELS, CHECK FOR ADEQUATE TURNING CLEARANCE BETWEEN THE FRONT OF ALL TRAILERS AND THE TRUCK CAB. ON TWO WHEEL DRIVE TRUCKS A CLEARANCE CHECK MUST BE PERFORMED WHEN TRUCK IS LOADED AND UNLOADED TO VERIFY THE INVERTED BALL WILL NOT INTERFERE WITH THE TOP OF THE DIFFERENTIAL

Note: On vehicles with an aluminum bed, it will be required that the center section of the gooseneck be isolated from aluminum with the galvanic isolator kit supplied.

5. Raise the center section into position between the cross arms with the gooseneck center cylinder offset towards the front of the vehicle. Slide the cross arms to the center section and rotate them into position. The leg of the angle cross arm with the holes should be against the center section and the bar cross arm holes should be offset toward the ground. Attach the cross arms to the center section using eight 1/2" x 1 1/2" hex bolts (4) and eight 1/2" conical toothed washers (5) as shown in **FIGURE B**. The angle cross arm will also require four 1/2" hex flange nuts (6) as shown.
6. Using the supplied fishwires, fishwire four 5/8" x 1 3/4" carriage bolts (3) and four 60649-SP spacers (8) Loosely attach the side plates (A) and (B) to the the frame with the supplied 5/8" hex flange nuts (2). Hold the side plates against the frame and adjust the placement of the cross arms as needed.
7. Loosely attach the side plates (A) nd (B) to the cross arms by inserting one 5/8" x 1 3/4" carriage bolt (3) with CM-SP9 spacer (7) in through the plate and out the angle cross arm. Attach with one 5/8" flange nut (2). To attach the bar cross arm, install one 1/2" x 1 1/2" hex bolt (4) and one 1/2" conical toothed washer (5) through the plate and into the cross arm. Repeat on other side.
8. **NOTE:** Torque all fasteners in the following order: **First:** Torque the center section to the front and rear cross arms. **Second:** Torque the side plates to the truck frame on both sides. **Third:** Torque the side plates to the front and rear cross arms. Torque all 5/8" fasteners to 210 ft-lbs and 1/2" fasteners to 110 ft-lbs.

(REFER TO 60607 GOOSENECK HITCH INSTRUCTIONS FOR INSTALLATION COMPLETION AND OPERATING PROCEDURES)

PERIODICALLY CHECK THIS GOOSENECK HITCH TO ENSURE THAT ALL FASTENERS ARE TIGHT AND THAT ALL STRUCTURAL COMPONENTS ARE SOUND.

DO NOT EXCEED VEHICLE MANUFACTURER'S RECOMMENDED TOWING CAPACITY.

CAB TO TRAILER CLEARANCE

REMOVAL OF REAR WINDOW ACCESSORIES MAY BE REQUIRED.

TRAILER

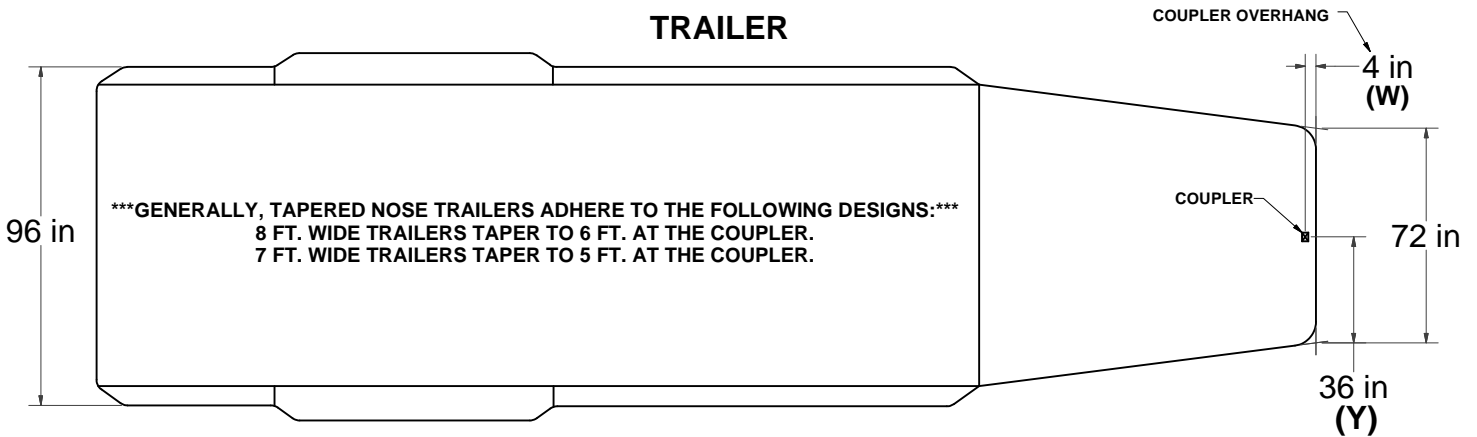

LONG BED

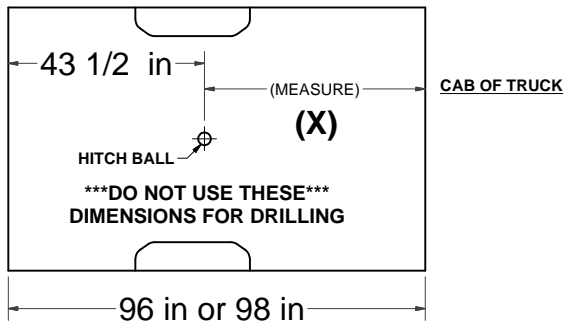

SHORT BED

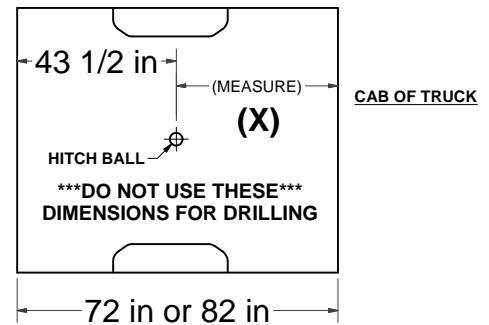

CLEARANCE CALCULATION

$$\text{(CAB TO BALL CENTER)} - \frac{1}{2} \text{(TRAILER WIDTH)} = \text{(MINIMUM CLEARANCE)}$$

$$(X) - (Y) = (Z)$$

IF THERE IS AN OVERHANG FROM THE COUPLER THEN THE EQUATION IS:

$$[(X) - (W)] - (Y) = (Z)$$

IF (Z) IS POSITIVE, TRAILER **WILL NOT** INTERFERE WITH CAB OF TRUCK.
 IF (Z) IS NEGATIVE, TRAILER **WILL** INTERFERE WITH CAB OF TRUCK!!!

EXAMPLE:

STANDARD TRAILER

$$X - Y = Z$$

$$35 - 36 = -1$$

(TRAILER **WILL INTERFERE** WITH CAB)

TRAILER WITH OVERHANG

$$[(X) - (W)] - Y = Z$$

$$[35 - 4] - 36 = -5$$

(TRAILER **WILL INTERFERE** WITH CAB)

YOUR CALCULATION:

(CAB TO BALL CENTER) _____

(COUPLER OVERHANG) _____

1/2 (TRAILER WIDTH) _____

(MINIMUM CLEARANCE) _____