

16427

RAM 2500 (WITHOUT PREP PACKAGE)



*** DO NOT EXCEED VEHICLE MANUFACTURER'S RECOMENDED TOWING CAPACITY ***

| Parts List | | | | Parts List | | | |
|------------|-----|------------------------------|--|------------|-----|-------------|----------------------------------|
| ITEM | QTY | PART NUMBER | DESCRIPTION | ITEM | QTY | PART NUMBER | DESCRIPTION |
| 1 | 10 | CM-SP136 | .313" x 1.00 x 2.00" U-SHAPE SPACER | A | 1 | 16427-PSF | .313" PASSENGER SIDE FRONT PLATE |
| 2 | 8 | CM-SP33 | .250 x 1.50 x 2.00" SQUARE HOLE SPACER | B | 1 | 16427-DSF | .313" DRIVER SIDE FRONT PLATE |
| 3 | 8 | 1/2-13 x 1 3/4 | CARRIAGE BOLT | C | 1 | 16427-DSR | .313" DRIVER SIDE REAR PLATE |
| 4 | 10 | HFN 1213, GR8 | HEX FLANGE NUT | D | 1 | 16427-PSR | .313" PASSENGER SIDE REAR PLATE |
| 5 | 2 | 1/2-13 x 4 1/2 | CARRIAGE BOLT | E | 2 | 16427-SP | .625 x 2.00 SPACER |
| 6 | 2 | CM-SP44 | .250 x 1.50 x 2.00" SQUARE HOLE SPACER | | | | |
| 7 | 6 | M12-1.5 x 35mm | HEX BOLT | | | | |
| 8 | 2 | M12 - 1.50 x 45 HEX TAP BOLT | HEX BOLT | | | | |
| 9 | 8 | 1/2" | CONICAL TOOTHED WASHER | | | | |
| 10 | 2 | 16427-TS | TUBE SPACER | | | | |

REAR OF TRUCK

REAR OF TRUCK

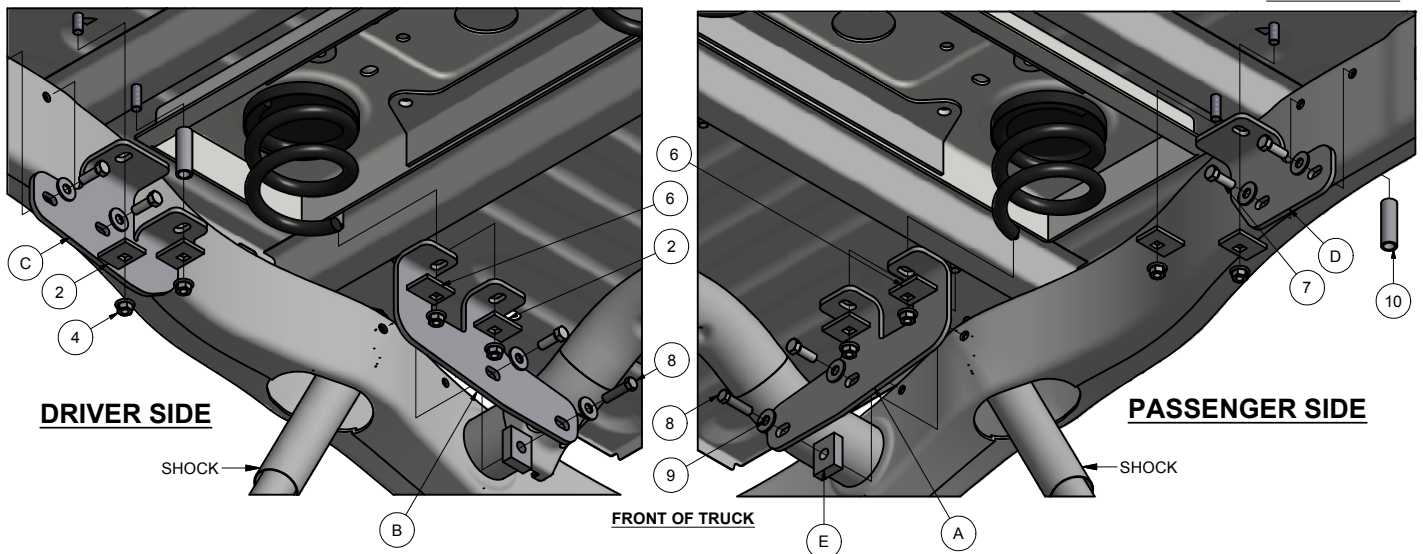

DRIVER SIDE

PASSENGER SIDE

SHOCK

SHOCK

FRONT OF TRUCK

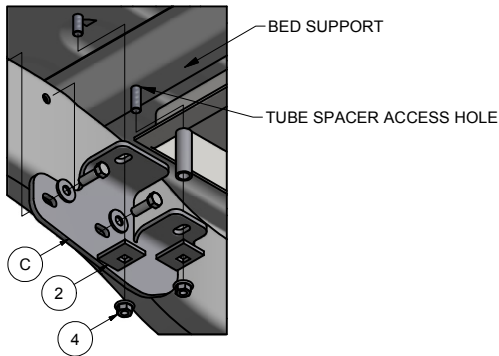

BED SUPPORT

TUBE SPACER ACCESS HOLE

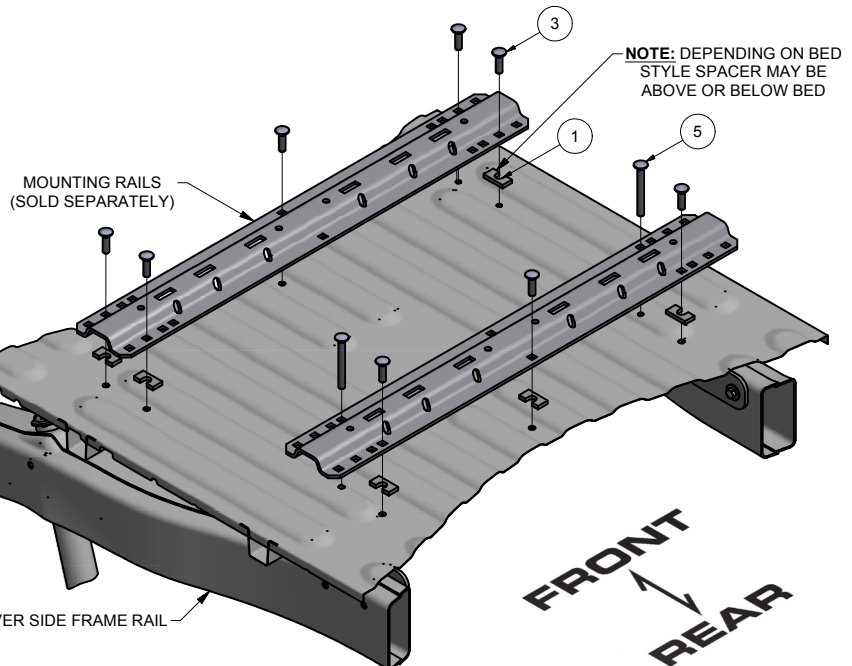

NOTE: DEPENDING ON BED STYLE SPACER MAY BE ABOVE OR BELOW BED

MOUNTING RAILS (SOLD SEPARATELY)

DRIVER SIDE FRAME RAIL

FRONT
REAR

HITCH WEIGHT: 25 LBS.

INSTALL TIME

PROFESSIONAL: 90 MINUTES

NOVICE (DIY): 180 MINUTES

INSTALL NOTES:

- LOWER SPARE TIRE
- NO DRILLING REQUIRED

16427

RAM 2500 (WITHOUT PREP PACKAGE)

WARNING:

- Do not install mounting rails over plastic bed liners. Plastic liners must be trimmed for metal to metal contact. (Mounting rails may be installed on spray on liner.)
- Use only supplied fasteners for installation.
- Before installing mounting rails and hitch, measure to be sure there will be enough clearance between the truck and trailer to allow for turns.

Installation Instructions:

1. Lower and remove the spare tire and exhaust heat shield for ease of installation.

WARNING: When drilling holes be aware of potential risks to vehicle components and make appropriate safe guards to protect them from damage.

2. Temporarily detach the wire and vacuum lines from in between the frame and the fuel tank to allow for the driver side front plate (B) to be placed into position.
3. Temporarily install the front mounting brackets (A & B) into position on the frame using 12mm bolts and 1/2" conical tooth washers into existing weldnuts in the frame (use spacers (E) as needed in front) with the plate straddling the truck bed support as shown on sheet 1. Pull the plates tight to the back of the bed support so that they are the same distance forward and aft. This is to make sure the mounting rail will be perpendicular to the length of the truck bed. Using a center punch, mark the locations of the center of the mounting rail hole locations in the bottom of the bed. Place the forward mounting rail in the bed of the truck and check to see that Rows 3 and 4 align with the center punch marks. Adjust center marks side to side as required. Move rail out of the way and drill 1/8" holes in Row 4 mounting locations. Check forward mounting brackets (A & B) to make sure they are aligned. Drill 1/8" holes in Row 3 mounting locations.
4. Remove the mounting rail and forward brackets (A & B) and enlarge the 1/8" holes to 9/16" in Rows 3 and 4. Reinstall the forward mounting brackets (A & B) and mounting rail with the 1/2" x 1-3/4" carriage bolts with the u-shaped spacers. Place the u-shaped spacers between the bracket or mounting rail and the bed to prevent the bed from collapsing when the bolts are tightened. Loosely install the supplied 1/2" flange nuts.
- 5a. Place the unassembled 5th wheel saddles / slider / goose into the already installed mounting rail. Position the second mounting rail with saddles / slider / goose by inserting the tabs into the mounting rail and pushing the mounting rail tight towards the other mounting rail. Ensure that the mounting rail is centered between the box sides on the length of the truck box floor. This will position the mounting rail in the correct location and ensure that the 5th wheel will have a snug fit to the truck. Drill the 1/8" holes in Row 1 and 2.

Note: If more than one hitch product will be used with the rails then both should be used at the same time to align the second rail. This will ensure that one product does not compromise the fit of the other.

If hitch attachment is not available use step 5b for rear mounting rail placement

- 5b. Place the rear mounting rail in the bed of the truck and place 22" on center from forward to rear rails. Center the rail side to side. Center punch the Row 1 hole locations. This process is to verify that the hole locations are correct due to bed support location variances. When aligned, drill the 1/8" holes in Row 1 and 2.

Note: If the wire harness interferes with the driver side rear bracket, Temporarily detach it from the inside of the driver side frame.

6. Enlarge the 1/8" holes to 9/16" in Rows 1 and 2.
7. From under the vehicle, enlarge the driver side hole in the rear bed support to 7/8". **Note:** Do not enlarge the holes in the bed. This will allow the tube spacer (10) to pass through easier. On the passenger side, slide the tube spacer (10) through the end of the bed support and into position of the drilled hole.

NOTE: Tube spacers may need to be shortened depending on the bed corrugation.

8. Install the 1/2" x 4-1/2" carriage bolts in the front holes of the rear rail (Row 2).
9. On the rear driver side, slide the tube spacer up through the bed support, around the carriage bolt. While holding the tube spacers in position, reinstall the rear mounting brackets (C & D) and mounting rail with the 1/2" x 1-3/4" carriage bolts with the u-shaped spacers in Row 1. Loosely install the supplied 12mm bolts and 1/2" conical washers and 1/2" flange nuts as shown on sheet 1.
10. Install the 1/2" x 1-3/4" carriage bolt in the center hole of the mounting rails as shown on sheet 1. Place a u-shaped spacer between the rail and the bed, and secure the bolt with as 1-1/2" x 2" spacer and 1/2" flange nut on the bottom.
11. Torque the fasteners in the following sequence:
 - a) mounting rails to the frame brackets to 110 lb-ft.
 - b) frame brackets to the truck frame to 96 lb-ft.
12. If detached, reattach the wire harness / vacuum lines, heat shield and spare tire.

16427

RAM 2500 (WITHOUT PREP PACKAGE)

WARNING:

- Do not install mounting rails over plastic bed liners. Plastic liners must be trimmed for metal to metal contact. (Mounting rails may be installed on spray on liner.)
- Use only supplied fasteners for installation.
- Before installing mounting rails and hitch, measure to be sure there will be enough clearance between the truck and trailer to allow for turns.

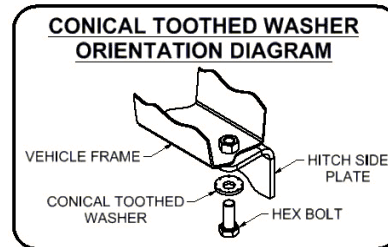
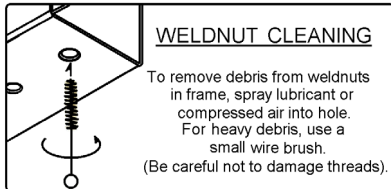
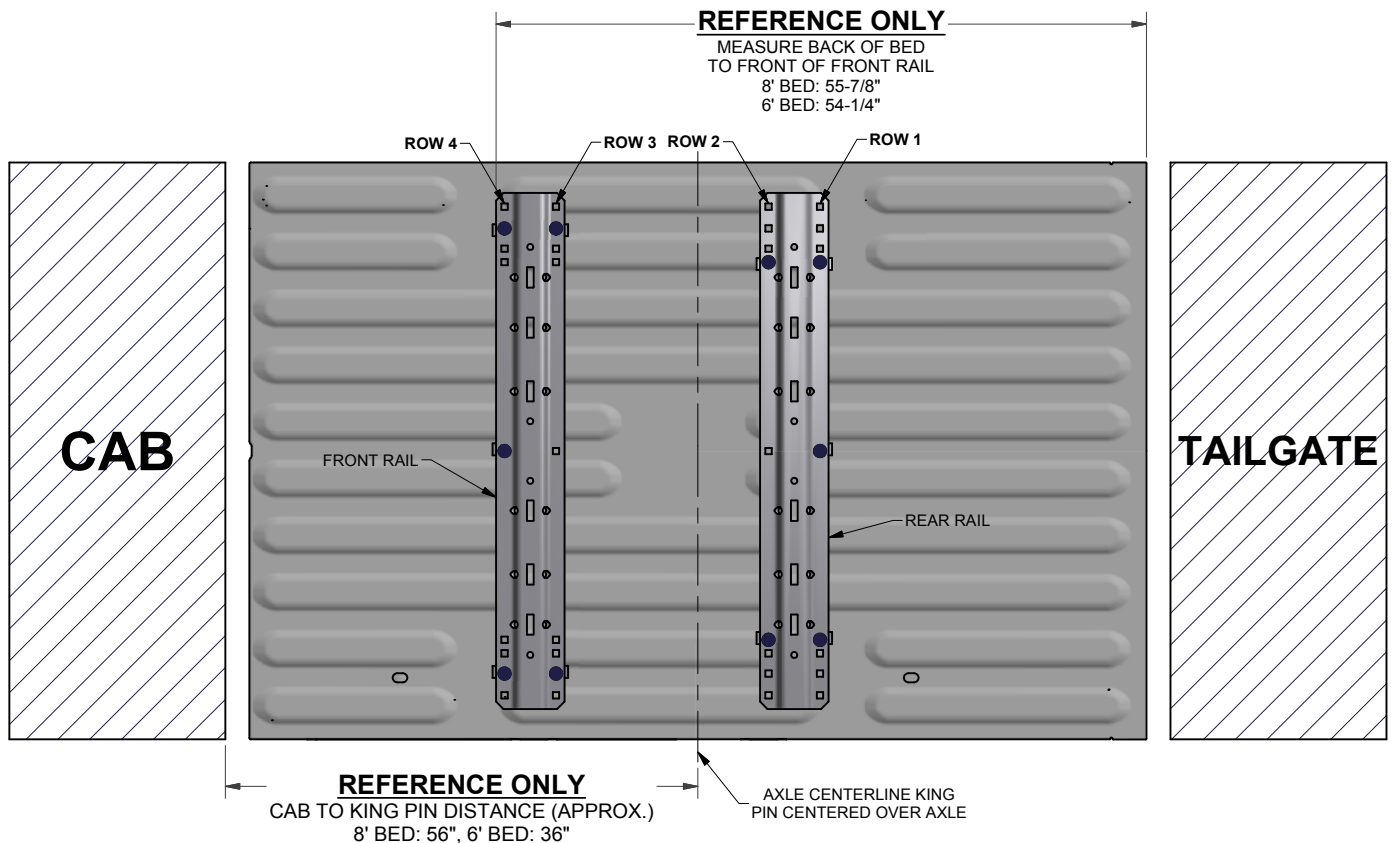

FIGURE 2: RAIL LOCATION DIAGRAM



Learn more about trailer hitches and towing we have.