

16306 2009-CURRENT DODGE RAM 1500, INCLUDING MEGACAB AND ECODIESEL

*** DO NOT EXCEED VEHICLE MANUFACTURER'S RECOMENDED TOWING CAPACITY ***

Parts List				Parts List			
ITEM	QTY	PART NUMBER	DESCRIPTION	ITEM	QTY	PART NUMBER	DESCRIPTION
1	18	1/2"	LOCK WASHER	A	1	16306-DSFWA	DRIVER SIDE FRONT WELDMENT
2	10	CM-SP136	.313" x 1.00 x 2.00" U-SHAPE SPACER	B	1	16306-PSF	.375" PASSENGER SIDE FRONT PLATE
3	18	1/2-13	HEX NUT	C	1	16306-DSR	.375" DRIVER SIDE REAR PLATE
4	10	FW12	FW, 12, ZP	D	1	16306-PSR	.375" PASSENGER SIDE REAR PLATE
5	8	1/2 - 13 x 1 1/2 WB	1/2 - 13 x 1 1/2 WHEEL BOLT				
6	10	1/2 - 13 x 2"	CARRIAGE BOLT				
7	1	1/2"	FISHWIRE TOOL				

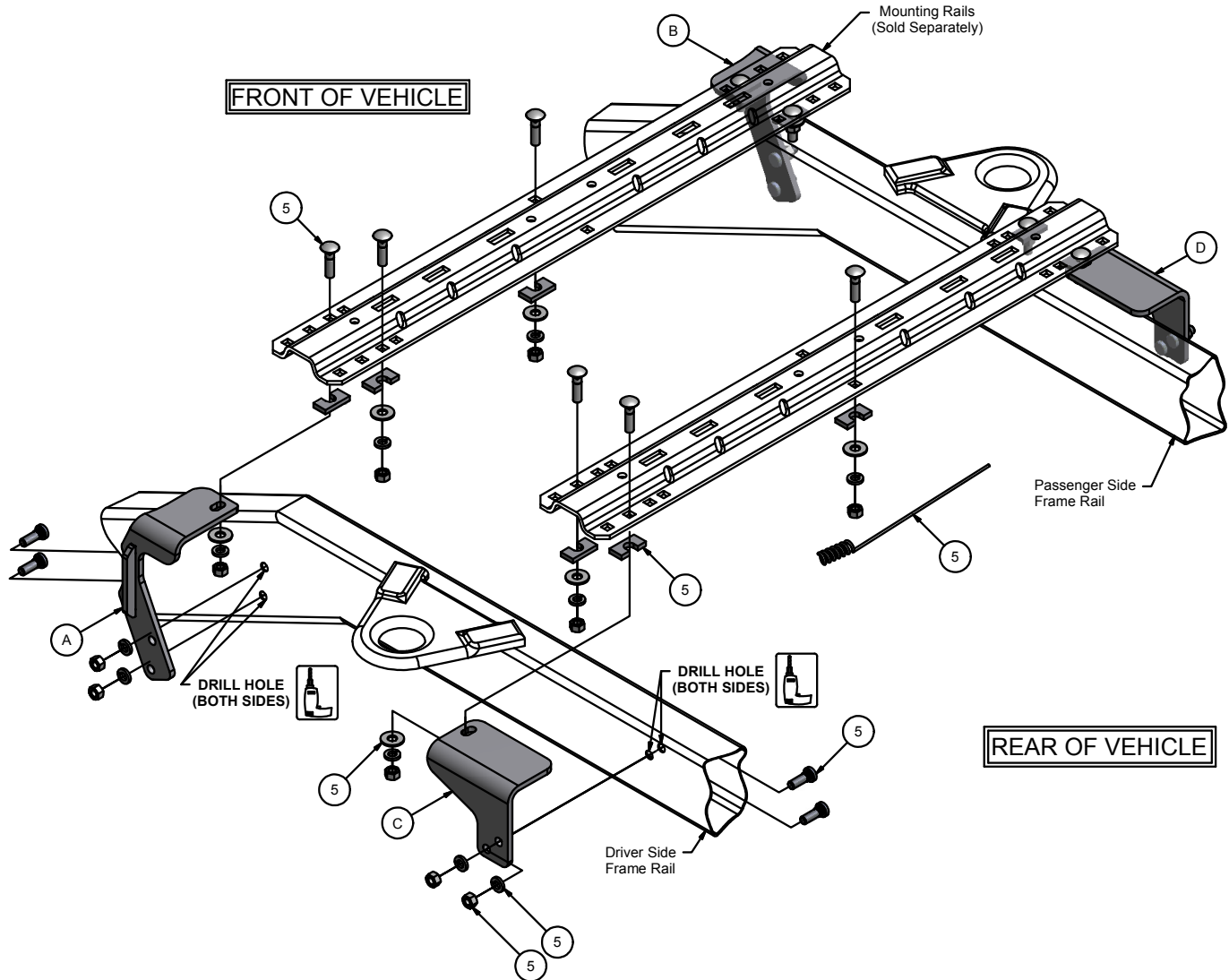

HITCH WEIGHT: 19 LBS.
 INSTALL TIME: 90 MINUTES
 INSTALL NOTES:

- DRILLING REQUIRED

FISHWIRE TECHNIQUE

INSERT COILED END OF FISHWIRE TOOL THROUGH HITCH MOUNTING HOLE IN VEHICLE FRAME RAIL AND OUT THE ACCESS HOLE. PASS COILED END OF FISHWIRE THROUGH SPACER AND THREAD BOLT INTO COIL. KINK WIRE TO KEEP SPACER SEPERATE FROM BOLT AS SHOWN. PULL FISHWIRE, SPACER, AND BOLT THROUGH FRAME AND OUT MOUNTING HOLE. USE FISHWIRE TO GUIDE HITCH DURING MOUNTING AND PREVENT LOSS OF BOLT / SPACER INSIDE FRAME RAIL.

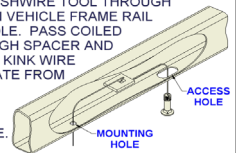

NOTE: SOME VEHICLES MAY FISHWIRE THROUGH END OF FRAME

GENERAL INSTRUCTIONS FOR MOUNTING RAIL INSTALLATION

TOOLS

3/16" drill	3/4" Socket & Open End Wrench
17/32" drill	100 lb-ft Torque Wrench
1" drill	"C" Clamps

1. The following instructions should be used to mount the 5th wheel. Care and attention to detail will ensure a quality installation. Check parts against parts list to become familiar with parts in kit. (See Fig. 1)
2. Raise rear of truck high enough to allow jack stands to be placed under rear spring hanger bracket of truck. This will provide maximum room to install the 5th wheel brackets.



WARNING:

If the truck is raised, be sure that the truck is properly blocked and restrained to prevent the truck from falling. Failure to do so may result in the truck suddenly falling, causing death or serious injury.

3. Do not install mounting rails over plastic bed liners. Plastic bed liners must be cut out of the way. Mounting rails may be installed on spray in liner. **Note:** Consult installer for recommended curing time.
4. Use only the supplied bolts, nuts, and washers to install this kit.
5. Specific instructions for most commonly used vehicles are included. If these instructions do not apply to your vehicle, be sure that each end of each base rail is connected to the vehicle frame. Each frame bracket must be bolted to the vehicle frame with two bolts, unless optional weld is used.



CAUTION:



These instructions are guidelines only. Actual installation is the responsibility of the installer and the owner. Always measure truck and trailer before installing hitch to be sure that there is clearance at the cab and at the bumper to allow for turns.

To prevent the trailer from hitting the cab with the trailer turned 90°, the center of the hitch should be at least 52" from the back of the cab when using a long bed truck. (Actual distance required will depend on trailer width and king pin location.) Short bed (Minimum 38" from back cab to axle center line) trucks require a minimum of a 13" extended pin box for regular maneuvers and do not apply.

6. Measurements are given from Rear Edge of truck bed to rear edge of the mounting rail closest to the Rear Edge of truck for most vehicle applications (See Fig. 2).
7. **Center hitch between fender wells and make sure rails are square. Adjust position of rails until both diagonal measurements are the same. This should allow installation of a gooseneck or other 5th wheels to these rails (See Fig. 2).**



CAUTION:



Check for obstructions before drilling. Failure to do so could result in damaged fuel or brake lines, structural members, etc. CURT MANUFACTURING does its best to communicate tow vehicle manufacturer changes; however, it is ultimately the responsibility of the installer to prevent damage due to installation.

8. Drill 10 holes identified in Fig. 2. (Hole location will vary for individual vehicle applications.) Drill all holes with 3/16" drill and enlarge them with a 17/32" drill. Always use sharp drill bits. A 3/16" pilot hole will greatly speed drilling larger holes. Install 1/2" carriage bolts into holes. Install 5/16" thick slotted spacer above or below bed to fill corrugations in bed floor.

9. Secure bolts through mounting brackets with serrated washers, lock washers, and hex nuts. Secure the other four bolts through the bed with flat washers, lock washers, and nuts.

10. Drill two holes in frame for each bracket. Select the holes which will give the greatest spread between bolts. Install eight 1/2"-13x1-3/8" ribbed neck bolts, (thread pointing out), lock washers, and hex nuts. Tighten nuts until bolt heads seat. Lubrication of knurls of all rib neck bolts is recommended.

Note: On vehicles with heavy duty suspensions, check for interference with bolts where brackets are mounted to frame. If interference with suspension spring results, cut bolt flush to nut outboard of frame or use weld option.



WARNING:

DO NOT lubricate threads. It may cause bolt failure.



CAUTION:



Check for obstructions before drilling. Failure to do so could result in damaged fuel or brake lines, structural members, etc. CURT MANUFACTURING does its best to communicate tow vehicle manufacturer changes; however, it is ultimately the responsibility of the installer to prevent damage due to installation.



CAUTION:



It is important that 17/32" drill be used for holes in chassis frame as rib neck bolts may break if too small a hole is used and neck may not grip if too large a hole is used.

11. Torque all nuts to 110 lb-ft

12. Pull wire provided to pull rib neck bolts through frame as needed per application

Drill locations will vary. See individual installation for location

Use mounting channel/cross member assembly to position rails (not included).

**** Diagonal Measurements must be the same for smooth**

Operation of 16500 rolling units **

Fig. 2

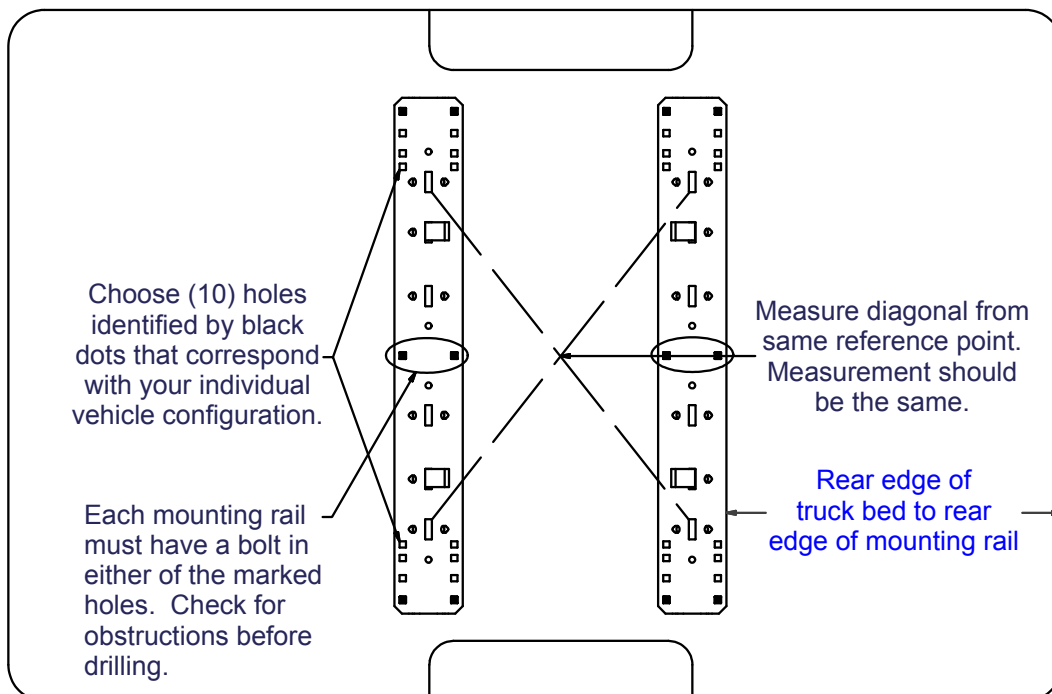

DODGE '09 AND NEWER 1500, INCLUDING MEGACAB

IMPORTANT NOTES FOR THIS INSTALLATION:

1. **Rib neck bolts will need to be pulled through access holes in frame with supplied pull wire (see below).
2. Do not drill thru both wall of frame. Drill only thru wall of frame to which bracket is mounted.
3. It is very important that brackets in Row 2 are against rear side of Bed Sill as shown. Due to dimensional instability in Bed Sill placement with the Dodge truck, interference could result when drilling in Row 3. Observe caution note below and double check all areas prior to drilling.
4. *Due to tubular frames having thinner walls than previous C channel frames, extra caution needs to be used when mounting with the optional welding.

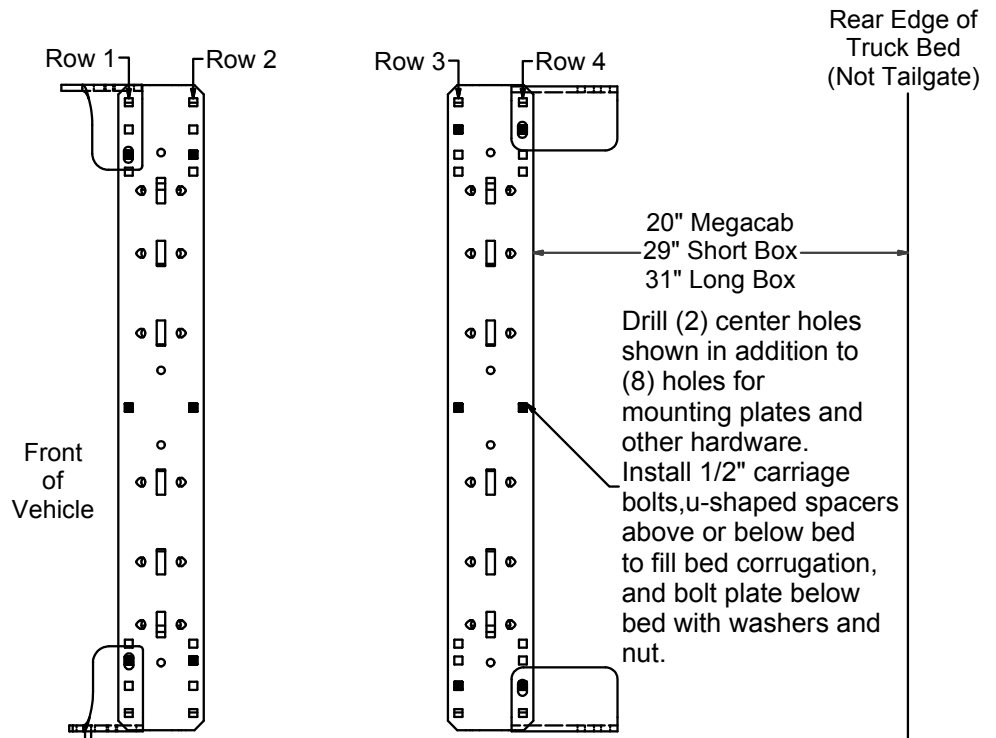

Measure from rear edge of truck bed to rear edge of mounting rail

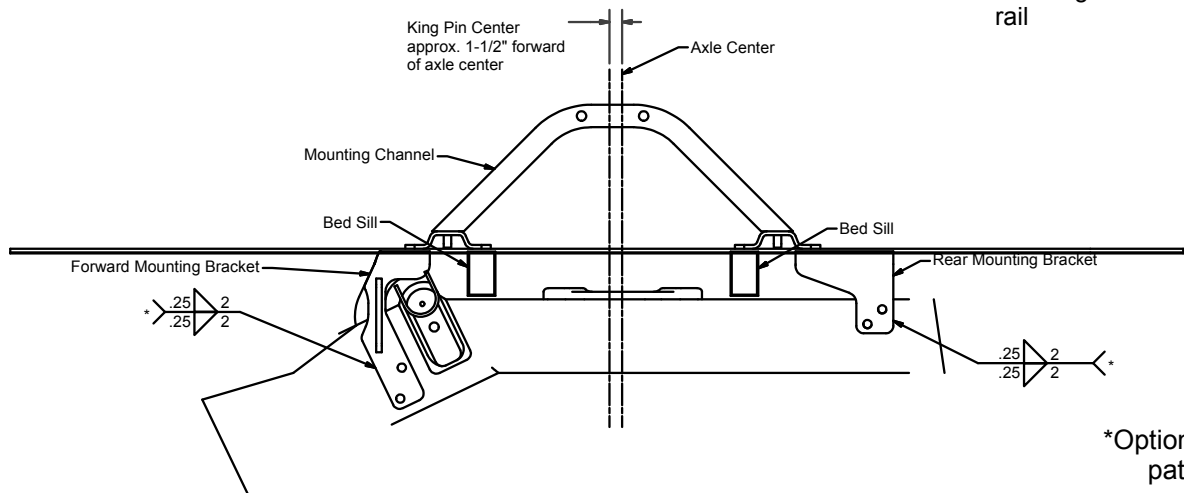

Check for obstructions before drilling. Failure to do so could result in damaged fuel or brake lines, structural members, etc. CURT MANUFACTURING does its best to communicate tow vehicle manufacturer changes; however, it is ultimately the responsibility of the installer to prevent damage due to installation.