

15703**CHEVY SILVERADO & GMC SIERRA 2500 & 3500 HD**

GROSS LOAD CAPACITY WHEN USED AS A WEIGHT CARRYING HITCH: 18,000 LBS. TRAILER WEIGHT & 2,700 LBS. TONGUE WEIGHT.
GROSS LOAD CAPACITY WHEN USED AS A WEIGHT DISTRIBUTION HITCH: 18,000 LBS. TRAILER WEIGHT & 2,700 LBS. TONGUE WEIGHT

DO NOT EXCEED VEHICLE MANUFACTURER'S RECOMMENDED TOWING CAPACITY.

Parts List			
ITEM	QTY	PART NUMBER	DESCRIPTION
1	4	9_16-12 FLANGE NUT	HEX FLANGE NUT
2	2	CM-SP70	.250 x 1.00 x 2.50" 9/16" SQUARE HOLE SPACER
3	4	9_16-12 x 1 3/4	CARRIAGE BOLT
4	2	CM-SP73	.250 x 1.25 x 2.00" 9/16" SQUARE HOLE SPACER
5	4	7/16-14 x 1 1/4	CARRIAGE BOLT
6	4	7/16-14	HEX FLANGE NUT
7	2	15703-MS	.313" MOUNTING STRAP

TOOLS REQUIRED

RATCHET WRENCH
 TORQUE WRENCH
 21mm SOCKET
 11/16" SOCKET
 7/8" SOCKET

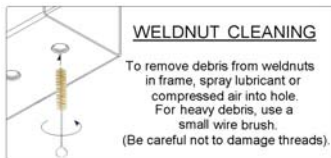

HITCH WEIGHT: 74 LBS.

INSTALL TIME

PROFESSIONAL: 30 MINUTES

NOVICE (DIY): 60 MINUTES

INSTALL NOTES:

- MAY REQUIRE DRILLING

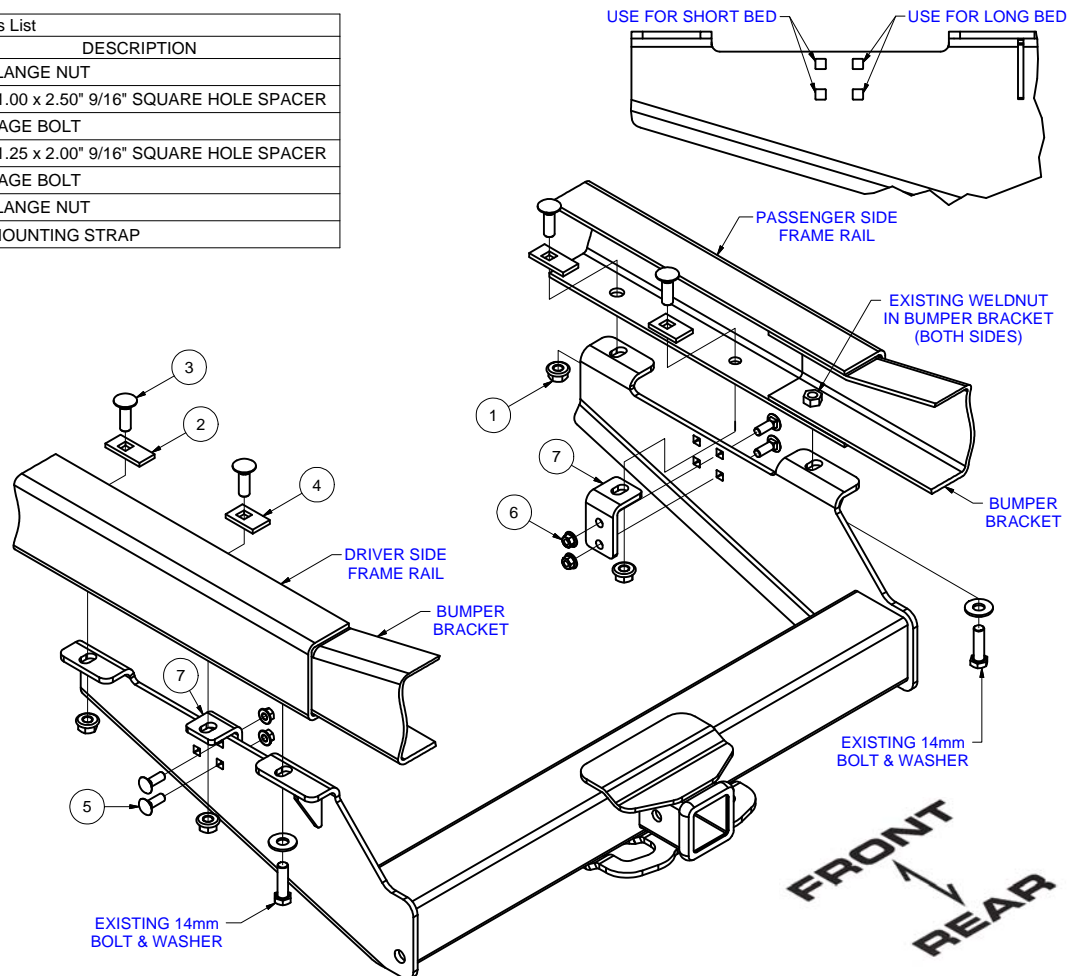
**INSTALLATION STEPS**

1. Remove spare tire for ease of installation.
2. Remove the 14mm bolts and washers that are located in the rear most bottom section of each frame rail. Save bolts for Step (3).
3. Raise hitch into position aligning the rear most holes in the hitch with 14mm weldnuts which the bolts were previously removed. Loosely attach hitch using 14mm hardware which was removed in Step (1)
4. Place 9/16" bolts and SP-70 spacers into forward-most mounting holes in the truck frame.
5. Install mounting straps to the inside of hitch side plates using two 7/16" bolts per side. These should be positioned to line up with holes in the vehicle frame rail, see diagram above for bed configurations.
6. Place the remaining SP-73 spacers and 9/16 bolts into position into center mouning locations. Attach to the mounting strap using 9/16" flange nuts.
7. Torque all 7/16" fasteners to 70 ft-lbs.
 Torque all 9/16" fasteners to 150 ft-lbs.
 Torque all 14mm fasteners to 154 ft-lbs.
8. Reinstall spare tire.

PERIODICALLY CHECK THIS RECEIVER HITCH TO ENSURE THAT ALL FASTENERS ARE TIGHT AND THAT ALL STRUCTURAL COMPONENTS ARE SOUND.