

14010

CHEVROLET / GMC 2500 / 3500 (LONG BOX)

GROSS LOAD CAPACITY WHEN USED AS A WEIGHT CARRYING HITCH: 10,000 LBS. TRAILER WEIGHT & 1,000 LBS. TONGUE WEIGHT.
GROSS LOAD CAPACITY WHEN USED AS A WEIGHT DISTRIBUTION HITCH: 12,000 LBS. TRAILER WEIGHT & 1,200 LBS. TONGUE WEIGHT

DO NOT EXCEED VEHICLE MANUFACTURER'S RECOMMENDED TOWING CAPACITY.

Parts List			
ITEM	QTY	PART NUMBER	DESCRIPTION
1	2	1/2-13 x 1 3/4	CARRIAGE BOLT
2	2	CM-SP1	.250 x 1.50 x 2.00" SQUARE HOLE SPACER
3	2	M14 - 2 x 45 HEX	HEX BOLT
4	6	HFN 1213	HEX FLANGE NUT
5	4	1/2-13 x 1 1/4	CARRIAGE BOLT
6	2	9/16" CONICAL WASHER	CONICAL TOOTHED WASHER
7	2	14010-ST	.250" STRAP PLATE

TOOLS REQUIRED
RATCHET
TORQUE WRENCH
10" EXTENSION
10mm & 21mm SOCKET
3/4" SOCKET

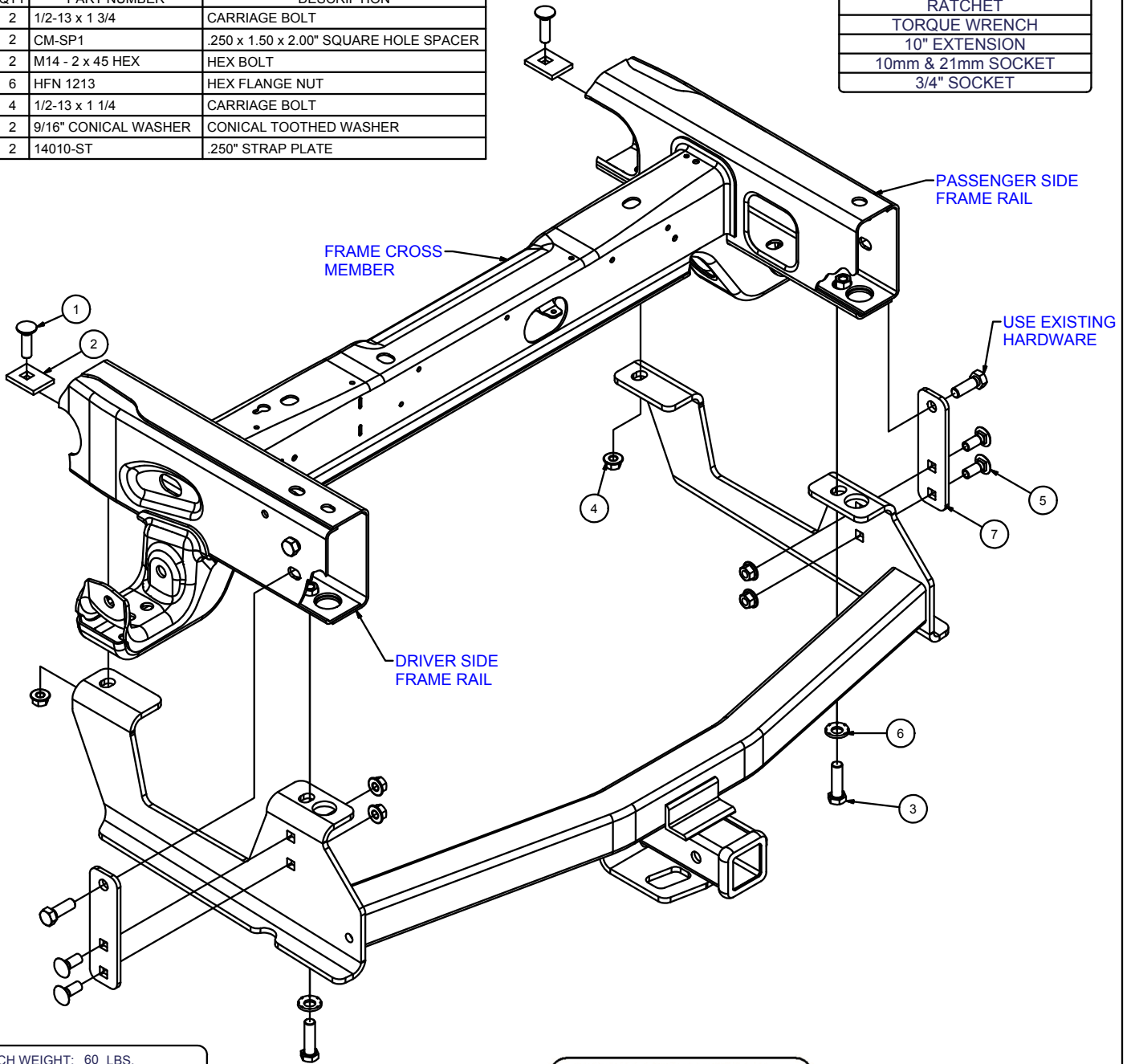

HITCH WEIGHT: 60 LBS.

INSTALL TIME

PROFESSIONAL: 20 MINUTES

NOVICE (DIY): 40 MINUTES

INSTALL NOTES:

- LOWER SPARE TIRE FOR EASE OF INSTALLATION
- NO DRILLING REQUIRED

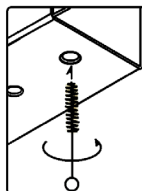

WELDNUIT CLEANING

To remove debris from weldnuts in frame, spray lubricant or compressed air into hole. For heavy debris, use a small wire brush. (Be careful not to damage threads).

CONICAL TOOTHED WASHER ORIENTATION DIAGRAM

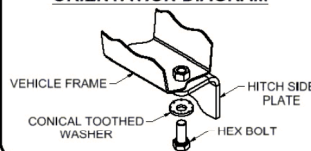

PERIODICALLY CHECK THIS RECEIVER HITCH TO ENSURE THAT ALL FASTENERS ARE TIGHT AND THAT ALL STRUCTURAL COMPONENTS ARE SOUND.

14010**CHEVROLET & GMC 2500 / 3500 (LONG BOX)**

GROSS LOAD CAPACITY WHEN USED AS A WEIGHT CARRYING HITCH: 10,000 LBS. TRAILER WEIGHT & 1,000 LBS. TONGUE WEIGHT.
GROSS LOAD CAPACITY WHEN USED AS A WEIGHT DISTRIBUTION HITCH: 12,000 LBS. TRAILER WEIGHT & 1,200 LBS. TONGUE WEIGHT

*****DO NOT EXCEED VEHICLE MANUFACTURER'S RECOMMENDED TOWING CAPACITY.*****

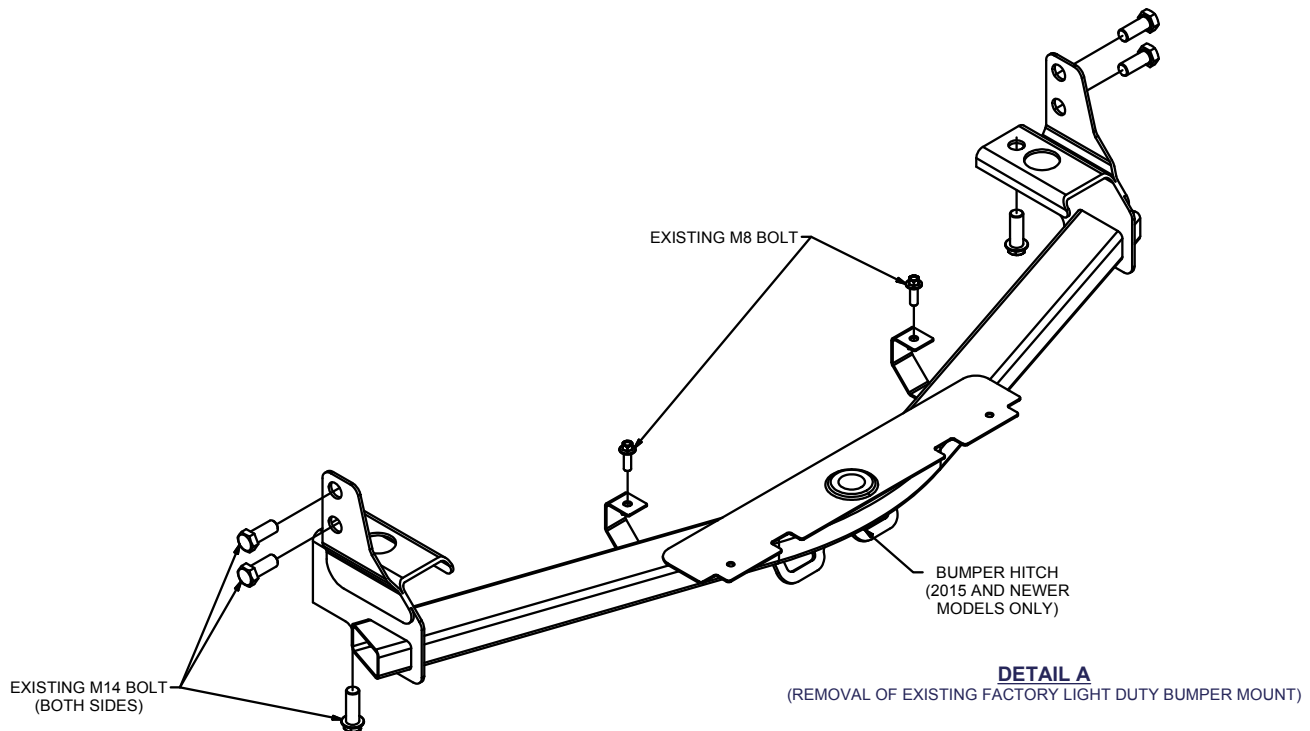
**INSTALLATION STEPS**

1. Temporarily lower spare tire from vehicle to ease installation.

NOTE: If removing factory hitch, retain the hardware for CURT hitch install.

2. On 2015 and newer non-hitch equipped vehicles you will need to remove a factory light duty bumper mount hitch prior to hitch installation.
Remove this light duty bumper hitch as follows (See Detail A);
 - a. Remove (2) M8 bolts connecting the center hitch tabs to the bumper and return to owner.
 - b. Remove and retain (4) M14 bolts that secure the hitch to the side of the frame rails.
 - c. Remove (2) M14 bolts that secure the rear of the hitch to the weldnuts in the bottom of the frame rails.
 - d. Remove the hitch and return to owner.
3. Raise hitch into position, locating holes in hitch over weldnuts in vehicle frame. Weldnut cleaning may be necessary. (See WELDNUT CLEANING DIAGRAM)
4. Install M14 bolts and conical toothed washers through hitch into weldnuts in the bottom of vehicle frame.
5. Install 1/2" carriage bolts, spacers, and nuts as shown above.
6. Install (2) M14 bolts removed from Step 2b into the side of the frame rail. Also install (2) carriage bolts through each strap plate into the side plate.
7. Torque all M14 fasteners to 126 ft-lbs, and all 1/2" fasteners to 110 ft-lbs.
8. Raise spare tire back into position on vehicle if lowered.

PERIODICALLY CHECK THIS RECEIVER HITCH TO ENSURE THAT ALL FASTENERS ARE TIGHT AND THAT ALL STRUCTURAL COMPONENTS ARE SOUND.