

YEARS: 2016-PRESENT

MAKE: BMW

MODEL: X1

STYLE: SUV

WEIGHT CARRYING:

TRAILER WEIGHT: 3,500 LBS.
TONGUE WEIGHT: 525 LBS.

PRO INSTALL TIME: 40 MIN.

NOVICE INSTALL TIME: 80 MIN.

IF YOU ARE HESITANT TO UNDERTAKE THIS TASK ON YOUR OWN, CONTACT AN AUTHORIZED CURT INSTALLER FOR ADDITIONAL ASSISTANCE.

INSTALLATION REQUIRES:

RATCHET	TORQUE WRENCH	POWER DRILL
8mm 3/4" SOCKET	6" SOCKET EXTENSION	DIE GRINDER
DRILL BIT 5/16" 9/16"	PRY BAR	MARKER
SAFETY GLASSES		

INSTALLATION TIPS:

1. BEFORE YOU BEGIN INSTALLATION, READ ALL INSTRUCTIONS THOROUGHLY.
2. TO EASE INSTALLATION, 2 PEOPLE MAY BE REQUIRED.
3. USING PROPER TOOLS WILL GREATLY IMPROVE THE QUALITY OF THE INSTALL AND REDUCE THE TIME REQUIRED.

LEVEL OF DIFFICULTY: MODERATE

EASY	MODERATE	CHALLENGING
	DRILLING REQUIRED	
	HOLE ENLARGEMENT REQUIRED	
	FISHWIRE TECHNIQUE	
	REVERSE FISHWIRE TECHNIQUE	
	LOWER (2) EXHAUST HANGERS	

VEHICLE PHOTO:



REPRESENTATIVE PHOTO

HITCH ILLUSTRATION:

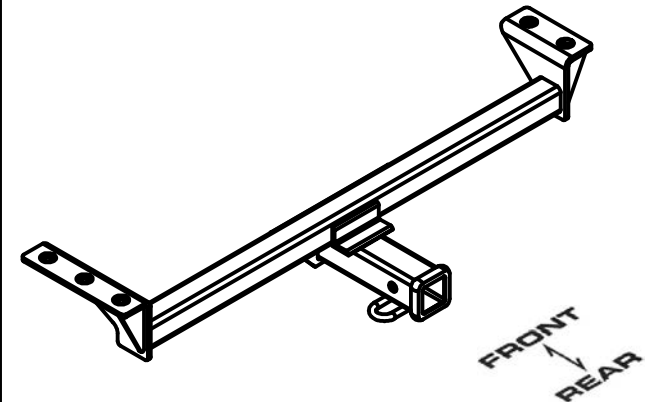

MAKE SURE YOUR HITCH MATCHES

INSTALLATION WALKTHROUGH:

Parts List			
ITEM	QTY	PART NUMBER	DESCRIPTION
1	5	1/2-13 x 1 1/4, GR8	CARRIAGE BOLT
2	5	HFN 1213, GR8	HEX FLANGE NUT
3	5	CM-SP12	.250 x 1.00 x 2.00" SQUARE HOLE SPACER
4	5	1_2 FISHWIRE	1/2" FISHWIRE

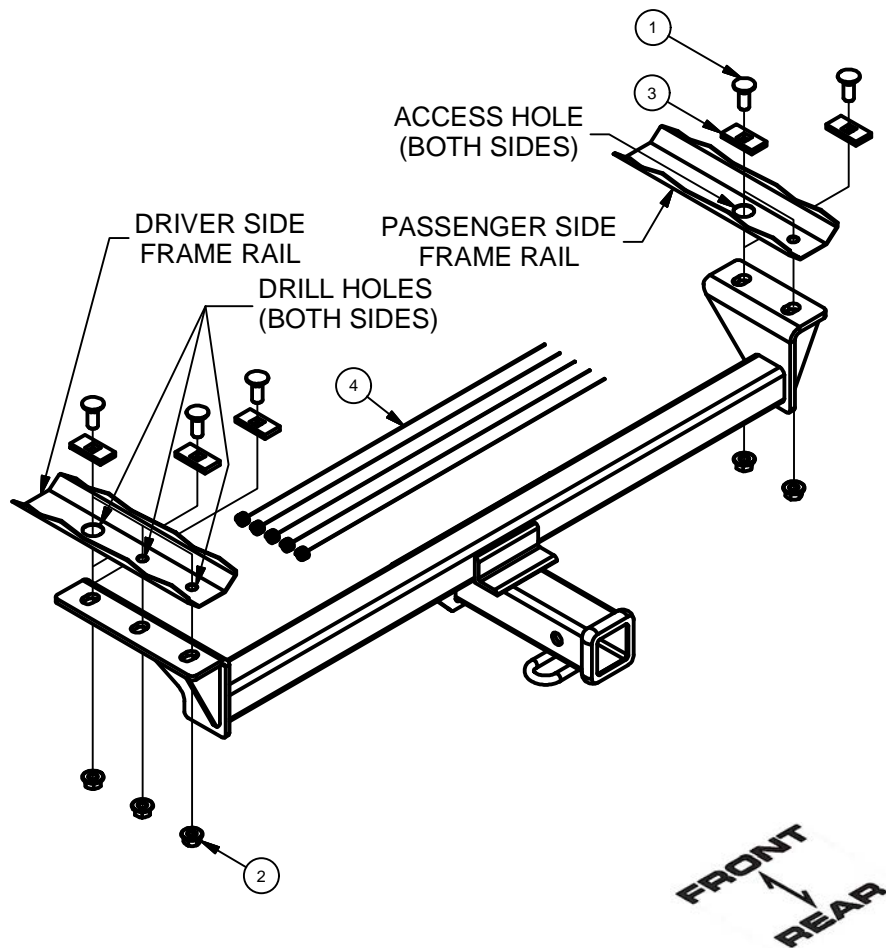

1. Lower the exhaust by removing the (2) rearmost rubber exhaust isolators from the frame mounted hangers. Be sure to support the exhaust during installation to prevent damage. (See Rubber Isolator Removal Diagram)

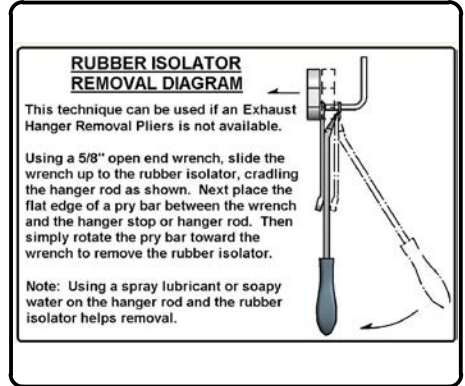
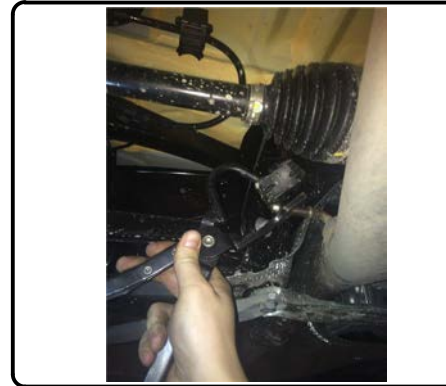

2. Temporarily remove lower fascia by removing (2) push clips (1) on each side using pry tool. Then remove (12) hex head screws along the bottom fascia using 8mm socket. Gently unclip lower fascia, set aside for reinstallation.

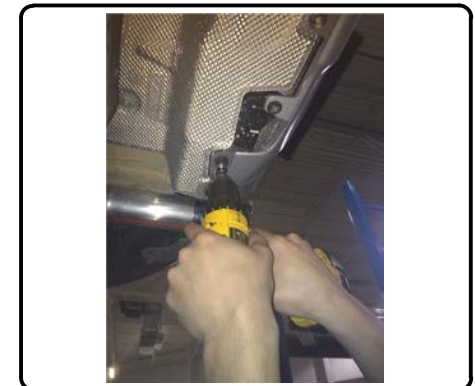

INSTALLATION WALKTHROUGH:

3. Raise hitch into position against back of the frame rail. Using the hitch as a template, center the holes on the frame and use a paint pen to mark out the (5) hole locations.

Note: Clearing away caulk could ease installation.



4. Lower the hitch and use a drill and 5/16" drill bit to drill (5) holes located at the marked areas from step 3. Then use 9/16" drill bit to open up the holes to the final size.

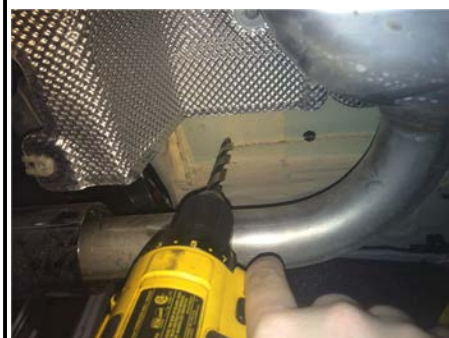

5. Use a die grinder to open up the (2) forward most holes (1) on each frame rail. (See hole enlargement diagram)

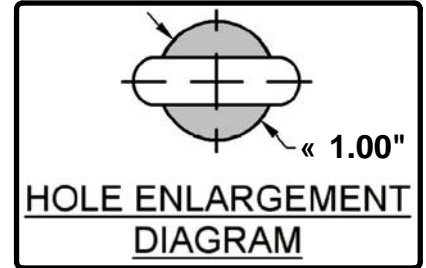
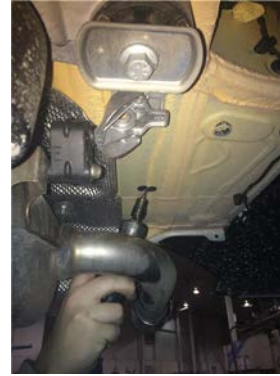

6. Using the forward-most holes that were enlarged in step 5, fishwire 1/2" carriage bolts (2) on driver side (1) on passenger side and CM-SP12 spacers (2) on driver side (1) on passenger side into the rear-most holes. (See fishwire diagram)

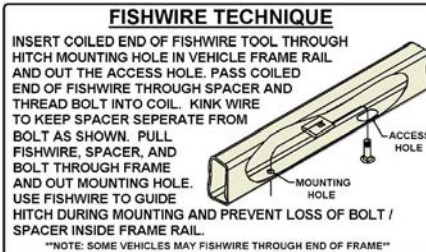

INSTALLATION WALKTHROUGH:

7. Using the forward-most holes that were enlarged in step 5 , reverse fishwire (2) 1/2" carriage bolts and (2) CM-SP12 spacers into the frame.
(See reverse fishwire diagram)

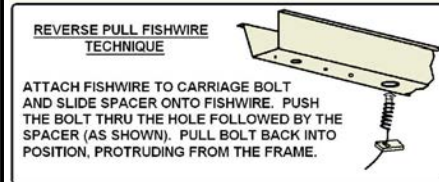

8. Raise hitch into position running the fishwires through the holes on the hitch. Remove fishwires and loosely fasten (5) 1/2" flange nuts.



9. Torque all fasteners to 110 ft-lbs. Raise the exhaust and reinstall the rubber isolators. Reinstall lower fascia removed in step 2.



TOWING SAFETY INFORMATION

Gross Trailer Weight / GTW

The Gross Trailer Weight is the weight of the trailer & cargo. Measure this by putting the fully loaded trailer on a vehicle scale.



Tongue Weight / TW

The downward force that is exerted on the hitch ball by the coupler. The tongue weight will vary depending on where the load is positioned in relationship to the trailer axle(s). To measure the tongue weight, use either a commercial scale or a bathroom scale with the coupler at towing height. When using a bathroom scale with heavier tongue weights, use the method shown and multiply the scale reading by 3.

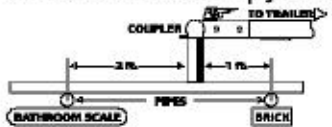

Weight Carrying / WC

The total weight of both the trailer and the cargo inside. Never exceed the weight capacity of your trailer hitch.

Weight Distribution / WD

Used to balance the weight of the cargo between the front and rear wheels throughout the trailer, allowing for better steering, braking, and level riding.



Sway Control

A device used to reduce the lateral movements of the trailer that are caused by the wind. This works in conjunction with a weight distribution hitch. Do not use this on a class 1 or 2 hitch, or with surge brakes.

How Much Can You Safely Tow?

TONGUE WEIGHT (lb.)	1000	2000	3000	4000	5000	6000	7000	8000	10,000	12,000	
CLASS 1	CLASS 1										
CLASS 2	CLASS 2										
CLASS 3	CLASS 3										
CLASS 4	CLASS 4										
CLASS 5	CLASS 5										
TRAILER TYPE	1000	2000	3000	4000	5000	6000	7000	8000	10,000	12,000	
Coupler											
1-1/2" Inc.	1100	1200	1300	1400	1500	1600					
Weighted											
1-1/2" Inc.	2100	2400	2700	3000	3300	3600	3900	4200	4500	4800	
Weighted											
1-1/2" Inc.	2800	3200	3600	4000	4400	4800	5200	5600	6000	6400	
2-1/2" Wheel											

Refer to owner's manual for towing capabilities and limitations.

Ball Mount

The ball mount is placed inside the opening of the receiver hitch which is mounted to the vehicle. Make sure a hitch pin and clip is properly securing the ball mount to the receiver hitch before you begin towing.

- A: Rise. B: Drop. C: Hole Size. D: Length.

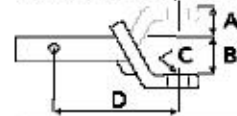

Trailer Ball

The connection from the hitch to the trailer. There are many factors that determine the correct hitch ball:

- Number one is the hitch ball's gross trailer weight rating.
- The mounting platform must be at least 3/8" thick.
- The hole diameter must not be more than 1/16" larger than the threaded shank.
- Every time you tow, check the nut and lock washer to make sure they are fastened securely.
- A: Ball Dia. B: Shank Length. C: Shank Dia. D: Shank Rise.

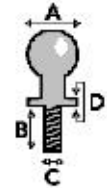

Coupler

The component that is placed over the trailer ball to connect the vehicle to the trailer. Be sure that the coupler size matches the size of the hitch ball and that the coupler handle is securely fastened. To determine what size hitch ball you need for your application you will need to know the size of coupler that is on the trailer. Be sure your coupler is properly adjusted to the ball you are using.

NOTE: For added security the use of safety devices such as Coupler Safety Pins and Locks is strongly recommended.

Safety Chains

Safety chains are a requirement and should be crossed under the tongue of the trailer so that the tongue will not drop to the road if it becomes separated from the hitch. Always leave enough slack so you can turn. Never allow the safety chains to drag on the ground and never attach the chains to the bumper.

Trailer Classification: Safety Chain Breaking Force - Minimum

Class 1: 2,000 lbs. (8.9 kN)

Class 2: 3,500 lbs. (15.6 kN)

Class 3: 5,000 lbs. (22.2 kN)

The strength rating of each length of safety chain or its equivalent and its attachments shall be equal to or exceed in minimum breaking force the GVWR (Gross Vehicle Weight Rating) of the trailer.

Electrical

Trailer lights, Electric Brakes, Break-away systems - Every time you tow, be sure to check that all components are working properly.

Wiring identification by color:



CURT DISCLAIMER: WIRING COLOR SHOWN WORK IN CONJUNCTION WITH CURT MANUFACTURING PRODUCTS.

13303

BMW X1

GROSS LOAD CAPACITY WHEN USED AS A WEIGHT CARRYING HITCH: 3,500 LBS. TRAILER WEIGHT & 525 LBS. TONGUE WEIGHT.

WARNING: *** DO NOT EXCEED VEHICLE MANUFACTURER'S RECOMMENDED TOWING CAPACITY. ***



Parts List			
ITEM	QTY	PART NUMBER	DESCRIPTION
1	5	1/2-13 x 1 1/4, GR8	CARRIAGE BOLT
2	5	HFN 1213, GR8	HEX FLANGE NUT
3	5	CM-SP12	.250 x 1.00 x 2.00" SQUARE HOLE SPACER
4	5	1_2 FISHWIRE	1/2" FISHWIRE

FISHWIRE TECHNIQUE

INSERT COILED END OF FISHWIRE TOOL THROUGH HITCH MOUNTING HOLE IN VEHICLE FRAME RAIL AND OUT THE ACCESS HOLE. PASS COILED END OF FISHWIRE THROUGH SPACER AND THREAD BOLT INTO COIL. KINK WIRE TO KEEP SPACER SEPERATE FROM BOLT AS SHOWN. PULL FISHWIRE, SPACER, AND BOLT THROUGH FRAME AND OUT MOUNTING HOLE. USE FISHWIRE TO GUIDE HITCH DURING MOUNTING AND PREVENT LOSS OF BOLT / SPACER INSIDE FRAME RAIL.

NOTE: SOME VEHICLES MAY FISHWIRE THROUGH END OF FRAME

REVERSE PULL FISHWIRE TECHNIQUE

ATTACH FISHWIRE TO CARRIAGE BOLT AND SLIDE SPACER ONTO FISHWIRE. PUSH THE BOLT THRU THE HOLE FOLLOWED BY THE SPACER (AS SHOWN). PULL BOLT BACK INTO POSITION, PROTRUDING FROM THE FRAME.

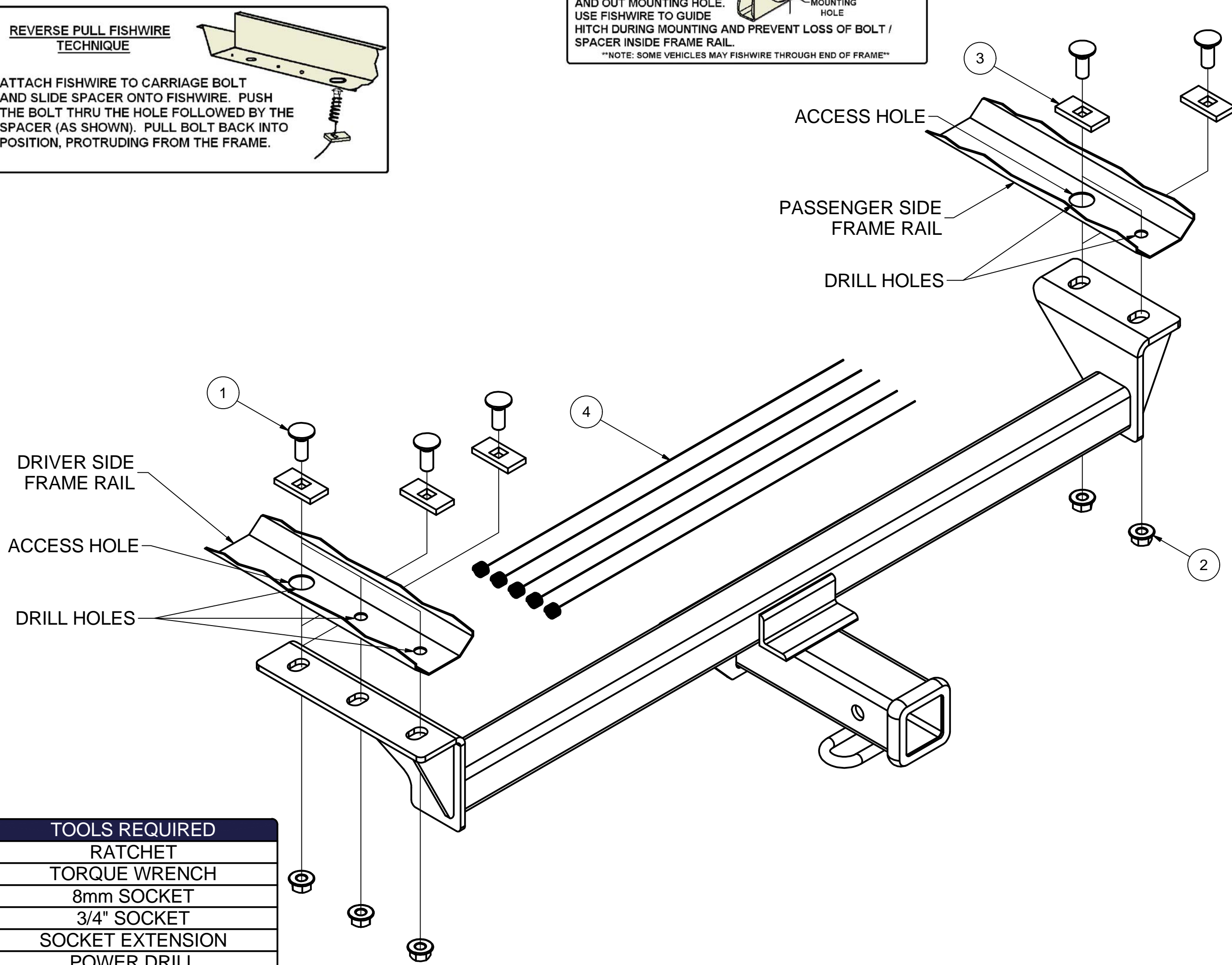

TOOLS REQUIRED
RATCHET
TORQUE WRENCH
8mm SOCKET
3/4" SOCKET
SOCKET EXTENSION
POWER DRILL
5/16" AND 9/16" DRILL BIT
SAFETY GLASSES
DIE GRINDER
PAINT MARKER
PRY BAR

HITCH WEIGHT: 33 LBS.

INSTALL TIME

PROFESSIONAL: 40 MINUTES

NOVICE (DIY): 80 MINUTES

INSTALL NOTES:

- DRILLING REQUIRED
- FISHWIRE
- REVERSE FISHWIRE
- LOWER EXHAUST

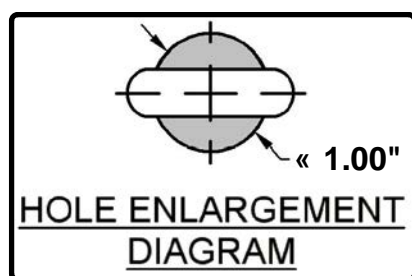

RUBBER ISOLATOR REMOVAL DIAGRAM

This technique can be used if an Exhaust Hanger Removal Pliers is not available.

Using a 5/8" open end wrench, slide the wrench up to the rubber isolator, cradling the hanger rod as shown. Next place the flat edge of a pry bar between the wrench and the hanger stop or hanger rod. Then simply rotate the pry bar toward the wrench to remove the rubber isolator.

Note: Using a spray lubricant or soapy water on the hanger rod and the rubber isolator helps removal.

FRONT
↑
REAR

PERIODICALLY CHECK THIS RECEIVER HITCH TO ENSURE THAT ALL FASTENERS ARE TIGHT AND THAT ALL STRUCTURAL COMPONENTS ARE SOUND.

INSTALLATION STEPS

1. Lower the exhaust by removing the (2) rearmost rubber exhaust isolators from the frame mounted hangers. Be sure to support the exhaust during installation to prevent damage. (See Rubber Isolator Removal Diagram.)
2. Temporarily remove lower fascia by removing (2) push clips (1) on each side using pry tool. Then remove (12) hex head screws along the bottom fascia using 8mm socket. Gently unclip lower fascia, set aside for reinstallation.
3. Raise hitch into position against the back of the frame rail. Using the hitch as a template, center the holes on the frame rail and use a paint pen to mark out the (5) hole locations.
Note: Clearing away caulk could ease installaion.
4. Lower the hitch and use a drill and 5/16" drill bit to drill (5) holes located at the marked areas from step 3. Then, use a 9/16" drill bit to open up the holes to the final size.
5. Use a die grinder to open up the (2) forward-most holes (1) on each frame rail. (See hole enlargement diagram)
6. Using the forward-most holes that were enlarged in step 5, fishwire 1/2" carriage bolts (2) on driver side (1) on passenger side and CM-SP12 spacers (2) on driver side (1) on passenger side into the rear-most holes. (See fishwire diagram)
7. Using the forward-most holes that were enlarged in step 5, reverse fishwire (2) 1/2" carriage bolts and (2) CM-SP12 spacers into the frame. (See reverse fishwire diagram).
8. Raise hitch into position running the fishwires through the holes on the hitch. Remove fishwires and loosely fasten (5) 1/2" flange nuts.
9. Torque all fasteners to 110 ft-lbs. Raise the exhaust and reinstall the rubber isolators. Reinstall lower fascia removed in step 2.

PERIODICALLY CHECK THIS RECEIVER HITCH TO ENSURE THAT ALL FASTENERS ARE TIGHT AND THAT ALL STRUCTURAL COMPONENTS ARE SOUND.