



# 13207 INSTALLATION INSTRUCTIONS



Safety glasses should be worn at all times while installing this product.

YEARS: 2014-PRESENT

MAKE: RAM

MODEL: PROMASTER

STYLE: VAN

**WARNING: NEVER EXCEED YOUR VEHICLE MANUFACTURER'S RECOMMENDED TOWING CAPACITY**

**WEIGHT CARRYING:**  
TRAILER WEIGHT: 6,000 LBS.  
TONGUE WEIGHT: 750 LBS.





**WEIGHT DISTRIBUTION:**  
TRAILER WEIGHT: 7,500 LBS.  
TONGUE WEIGHT: 750 LBS.

**PRO INSTALL TIME: 20 MIN.**  
**NOVICE INSTALL TIME: 40 MIN.**  
*IF YOU ARE HESITANT TO UNDERTAKE THIS TASK ON YOUR OWN, CONTACT AN AUTHORIZED CURT INSTALLER FOR ADDITIONAL ASSISTANCE.*

**INSTALLATION TIPS:**  
1. BEFORE YOU BEGIN INSTALLATION, READ ALL INSTRUCTIONS THOROUGHLY.  
2. TO EASE INSTALLATION, 2 PEOPLE MAY BE REQUIRED.  
3. USING PROPER TOOLS WILL GREATLY IMPROVE THE QUALITY OF THE INSTALL AND REDUCE THE TIME REQUIRED.



**INSTALLATION REQUIRES:**

 RATCHET	 3/4" 7/8" SOCKET	 TORQUE WRENCH
 SCREW DRIVER		

**LEVEL OF DIFFICULTY: EASY**

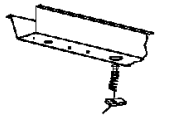
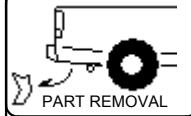
EASY	MODERATE	CHALLENGING
	NO DRILLING REQUIRED	
	REVERSE FISHWIRE (2) FASTENERS	
	REMOVE (2) RUBBER PLUGS FROM FRAME RAIL	

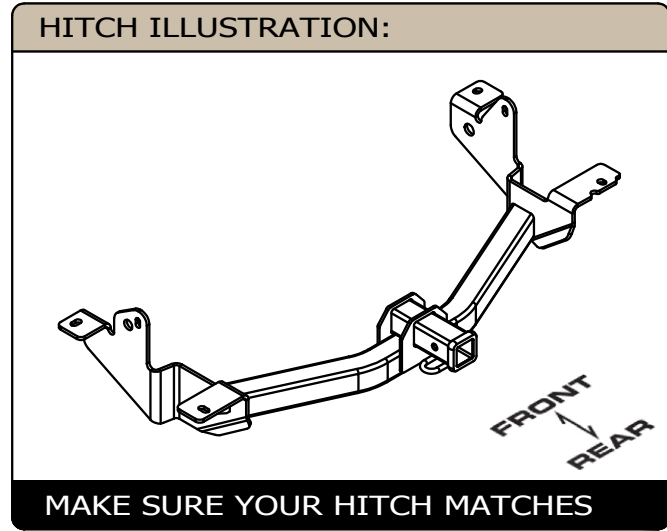

## INSTALLATION WALKTHROUGH:

Parts List			
ITEM	QTY	PART NUMBER	DESCRIPTION
1	1	9_16-12 x 2.5 CARRIAGE BOLT	CARRIAGE BOLT
2	1	9_16-12 x 2 CARRIAGE BOLT	CARRIAGE BOLT
3	2	CM-SP70	.250 x 1.00 x 2.50" 9/16" SQUARE HOLE SPACER
4	2	9_16-12 FLANGE NUT	HEX FLANGE NUT
5	2	9_16 FISHWIRE	9/16" FISHWIRE
6	2	1/2-13	HANDLE NUT
7	2	1/2-13 x 5 1/2	HEX BOLT
8	2	FW12	FW, 12, ZP
9	2	1_2 - 13 x 1 1_2 HEX, GR8	HEX BOLT
10	2	1/2	CONICAL TOOTHED WASHER
11	2	HFN 1213, GR8	HEX FLANGE NUT
12	1	13207-SP	.625 x 2.00 SPACER

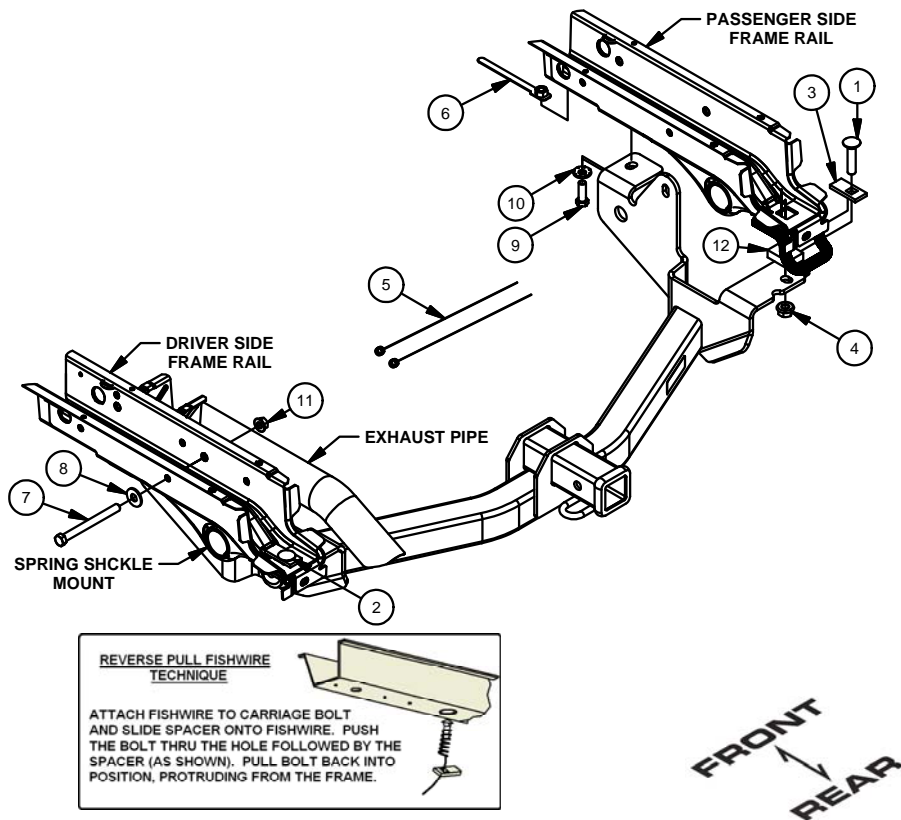

1. Remove the rearwardmost rubber plugs in the frame rails and foil (if present) covering the mounting holes. Return to owner. Fishwire the 9/16" x 2 1/2" carriage bolt and CM-SP70 spacer on the side with the recovery loop, and the 9/16" x 2" carriage bolt and CM-SP70 spacer into the holes that had the rubber plugs.

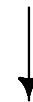

- 2a. Raise the hitch on the driver side with the forwardmost tab over the leaf spring and angle hitch to get the forwardmost tab on the passenger side over the leaf spring. Once in position, lift the driver side bracket up to the frame rail and slide the hitch over the rear bumper stud and the inner frame stud.



## INSTALLATION WALKTHROUGH:

2b. Loosely secure driver side bracket with a 9/16" hex flange nut. Pushing the hitch toward the driver side, raise the passenger side bracket up to the frame. Slide the 13207-SP between the hitch and the frame with the bolt passing through and loosely secure with a 9/16" hex flange nut.



3. Slide the (2) 1/2" handle nuts into the grooved section of the frame over the forwardmost tabs and secure with 1/2" x 1 1/2" hex bolts and conical tooth washers. Slide the 1/2" x 5 1/2" hex bolts with washers through the frame and hitch brackets. Secure with 1/2" hex flange nuts.



4. Torque all 9/16" fasteners to 150 lb-ft and all 1/2" fasteners to 110 lb-ft.





## TOWING SAFETY INFORMATION

### Gross Trailer Weight / GTW

The Gross Trailer Weight is the weight of the trailer & cargo. Measure this by putting the fully loaded trailer on a vehicle scale.

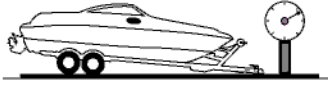

### Tongue Weight / TW

The downward force that is exerted on the hitch ball by the coupler. The tongue weight will vary depending on where the load is positioned in relationship to the trailer axle(s). To measure the tongue weight, use either a commercial scale or a bathroom scale with the coupler at towing height. When using a bathroom scale with heavier tongue weights, use the method shown and multiply the scale reading by 3.

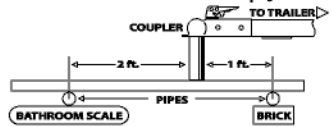

### Weight Carrying / WC

The total weight of both the trailer and the cargo inside. Never exceed the weight capacity of your trailer hitch.

### Weight Distribution / WD

Used to balance the weight of the cargo between the front and rear wheels throughout the trailer, allowing for better steering, braking, and level riding.



### Sway Control

A device used to reduce the lateral movements of the trailer that are caused by the wind. This works in conjunction with a weight distribution hitch. Do not use this on a class 1 or 2 hitch, or with surge brakes.

### How Much Can You Safely Tow?

TONGUE WEIGHT (lb)	1000	2000	3000	4000	5000	6000	7000	8000	10,000	12,000
Tongue weight should be about 10 to 15 percent of the gross trailer weight.										
CLASS 1										
CLASS 2										
CLASS 3										
CLASS 4										
CLASS 5										
TRAILER TYPE										
Camper	11'	12'	13'	14'	15'	16'				
lbs.	1100	1200	1300	1400	1500	1600				
Vacation	18'	19'	20'	21'	22'	24'	26'	28'	30'	32'
lbs.	2100	2400	2700	3000	3300	3600	3900	4200	4500	4800
Vacation	18'	19'	20'	21'	22'	24'	26'	28'	30'	32'
lbs.	2800	3200	3600	4000	4400	4800	5200	5600	6000	6400
5th Wheel										

**Refer to owner's manual for towing capabilities and limitations.**

### Ball Mount

The ball mount is placed inside the opening of the receiver hitch which is mounted to the vehicle. Make sure a hitch pin and clip is properly securing the ball mount to the receiver hitch before you begin towing.

- A: Rise. B: Drop. C: Hole Size. D: Length.

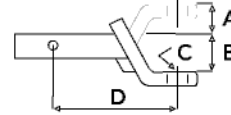

### Trailer Ball

The connection from the hitch to the trailer. There are many factors that determine the correct hitch ball:

- Number one is the hitch ball's gross trailer weight rating.
- The mounting platform must be at least 3/8" thick.
- The hole diameter must not be more than 1/16" larger than the threaded shank.
- Every time you tow, check the nut and lock washer to make sure they are fastened securely.
- A: Ball Dia. B: Shank Length. C: Shank Dia. D: Shank Rise.

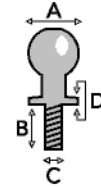

### Coupler

The component that is placed over the trailer ball to connect the vehicle to the trailer. Be sure that the coupler size matches the size of the hitch ball and that the coupler handle is securely fastened. To determine what size hitch ball you need for your application you will need to know the size of coupler that is on the trailer. Be sure your coupler is properly adjusted to the ball you are using.

NOTE: For added security the use of safety devices such as Coupler Safety Pins and Locks is strongly recommended.

### Safety Chains

Safety chains are a requirement and should be crossed under the tongue of the trailer so that the tongue will not drop to the road if it becomes separated from the hitch. Always leave enough slack so you can turn. Never allow the safety chains to drag on the ground and never attach the chains to the bumper.

Trailer Classification: Safety Chain Breaking Force - Minimum

Class 1: 2,000 lbs. (8.9 kN)

Class 2: 3,500 lbs. (15.6 kN)

Class 3: 5,000 lbs. (22.2 kN)

The strength rating of each length of safety chain or its equivalent and its attachments shall be equal to or exceed in minimum breaking force the GVWR (Gross Vehicle Weight Rating) of the trailer.

### Electrical

Trailer lights, Electric Brakes, Break-away systems - Every time you tow, be sure to check that all components are working properly.

Wiring identification by color:

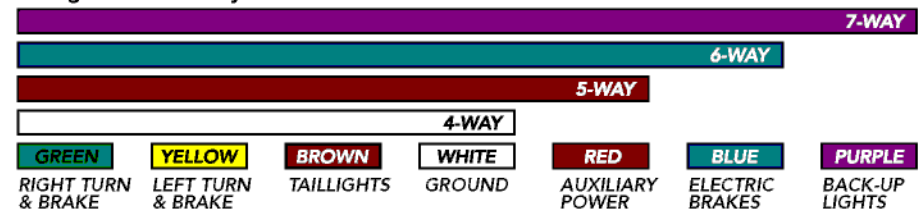

CURT DISCLAIMER: WIRING COLOR SHOWN WORK IN CONJUNCTION WITH CURT MANUFACTURING PRODUCTS.

**13207****RAM Promaster****3/5/2015**

**GROSS LOAD CAPACITY WHEN USED AS A WEIGHT CARRYING HITCH: 6,000 LBS. TRAILER WEIGHT & 750 LBS. TONGUE WEIGHT.  
GROSS LOAD CAPACITY WHEN USED AS A WEIGHT DISTRIBUTION HITCH: 7,500 LBS. TRAILER WEIGHT & 750 LBS. TONGUE WEIGHT**

\*\*\*DO NOT EXCEED VEHICLE MANUFACTURER'S RECOMMENDED TOWING CAPACITY.\*\*\*

Parts List			
ITEM	QTY	PART NUMBER	DESCRIPTION
1	1	9_16-12 x 2.5 CARRIAGE BOLT	CARRIAGE BOLT
2	1	9_16-12 x 2 CARRIAGE BOLT	CARRIAGE BOLT
3	2	CM-SP70	.250 x 1.00 x 2.50" 9/16" SQUARE HOLE SPACER
4	2	9_16-12 FLANGE NUT	HEX FLANGE NUT
5	2	9_16 FISHWIRE	9/16" FISHWIRE
6	2	1/2-13	HANDLE NUT
7	2	1/2-13 x 5 1/2	HEX BOLT
8	2	FW12	FW, 12, ZP
9	2	1_2 - 13 x 1 1_2 HEX, GR8	HEX BOLT
10	2	1/2	CONICAL TOOTHED WASHER
11	2	HFN 1213, GR8	HEX FLANGE NUT
12	1	13207-SP	.625 x 2.00 SPACER

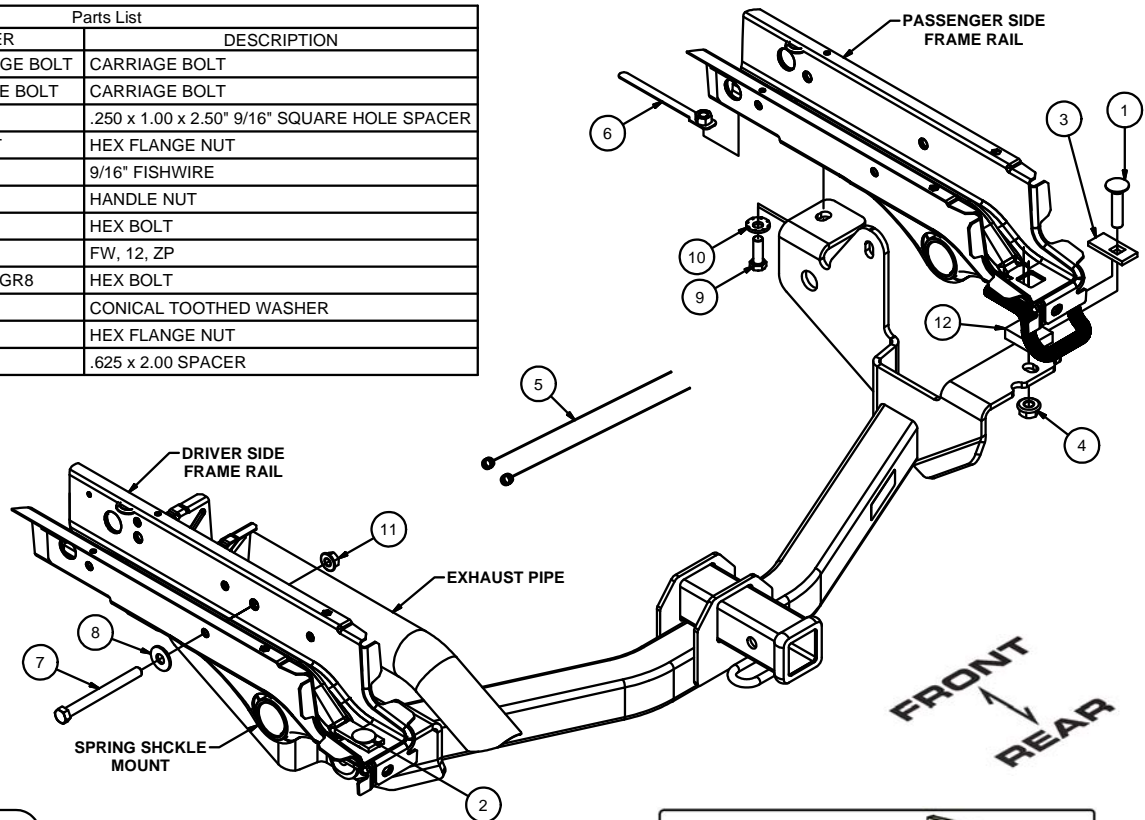

HITCH WEIGHT: 60 LBS.

**INSTALL TIME**

PROFESSIONAL: 20 MINUTES

NOVICE (DIY): 40 MINUTES

**INSTALL NOTES:**

- REMOVE RUBBER PLUGS
- REVERSE FISHWIRE
- NO DRILLING

**TOOLS REQUIRED**

RATCHET

TORQUE WRENCH

3/4" SOCKET

7/8" SOCKET

SMALL SCREW DRIVER

**REVERSE PULL FISHWIRE TECHNIQUE**

ATTACH FISHWIRE TO CARRIAGE BOLT AND SLIDE SPACER ONTO FISHWIRE. PUSH THE BOLT THRU THE HOLE FOLLOWED BY THE SPACER (AS SHOWN). PULL BOLT BACK INTO POSITION, PROTRUDING FROM THE FRAME.

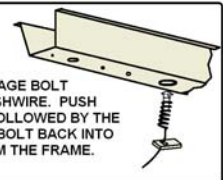
**INSTALLATION STEPS**

1. Remove the rearwardmost rubber plugs in the frame rails and foil (if present) covering the mounting holes. Return to owner. Fishwire the 9/16" x 2 1/2" carriage bolt and CM-SP70 spacer on the side with the recovery loop, and the 9/16" x 2" carriage bolt and CM-SP70 spacer into the holes that had the rubber plugs.
2. Raise the hitch on the driver side with the forwardmost tab over the leaf spring and angle hitch to get the forwardmost tab on the passenger side over the leaf spring. Once in position, lift the driver side bracket up to the frame rail and slide the hitch over the rear bumper stud and the inner frame stud, loosely secure with a 9/16" hex flange nut. Pushing the hitch toward the driver side, raise the passenger side bracket up to the frame. Slide the 13207-SP between the hitch and the frame with the bolt passing through and loosely secure with a 9/16" hex flange nut.
3. Slide the (2) 1/2" handle nuts into the grooved section of the frame over the forwardmost tabs and secure with 1/2" x 1 1/2" hex bolts and conical tooth washers. Slide the 1/2" x 5 1/2" hex bolts with washers through the frame and hitch brackets. Secure with 1/2" hex flange nuts.
4. Torque all 9/16" fasteners to 150 lb-ft and all 1/2" fasteners to 110 lb-ft.

PERIODICALLY CHECK THIS RECEIVER HITCH TO ENSURE THAT ALL FASTENERS ARE TIGHT AND THAT ALL STRUCTURAL COMPONENTS ARE SOUND.

Learn more about trailer hitches and towing we have.