



Safety glasses should be worn at all times while installing this product.

YEARS: 2010-PRESENT

MAKE: SUBARU

MODEL: LEGACY

STYLE: SEDAN

WARNING: NEVER EXCEED YOUR VEHICLE MANUFACTURER'S RECOMMENDED TOWING CAPACITY

WEIGHT CARRYING:
 TRAILER WEIGHT: 4,000 LBS.
 TONGUE WEIGHT: 600 LBS.

WEIGHT DISTRIBUTION:
 TRAILER WEIGHT: N/A LBS.
 TONGUE WEIGHT: N/A LBS.

PRO INSTALL TIME: 45 MIN.
NOVICE INSTALL TIME: 90 MIN.

IF YOU ARE HESITANT TO UNDERTAKE THIS TASK ON YOUR OWN, CONTACT AN AUTHORIZED CURT INSTALLER FOR ADDITIONAL ASSISTANCE.

INSTALLATION TIPS:

- BEFORE YOU BEGIN INSTALLATION, READ ALL INSTRUCTIONS THOROUGHLY.
- TO EASE INSTALLATION, 2 PEOPLE MAY BE REQUIRED.
- USING PROPER TOOLS WILL GREATLY IMPROVE THE QUALITY OF THE INSTALL AND REDUCE THE TIME REQUIRED.



INSTALLATION REQUIRES:

SPRAY LUBRICANT	PRY BAR	WIRE
RATCHET	8" SOCKET EXTENSION	10mm 3/4" SOCKET
MARKER	AVIATION SHEARS	DIE GRINDER
POWER DRILL	DRILL BIT 17/32"	TORQUE WRENCH

LEVEL OF DIFFICULTY: CHALLENGING

EASY	MODERATE	CHALLENGING
		LOWER EXHAUST
		HOLE ENLARGEMENT
		FISHWIRE HARDWARE
		HEAT SHIELD TRIMMING
		DRILLING REQUIRED

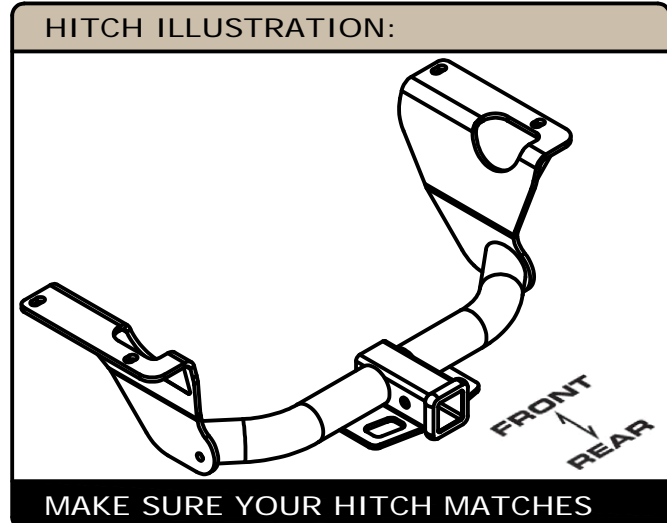

INSTALLATION WALKTHROUGH:

Parts List			
ITEM	QTY	PART NUMBER	DESCRIPTION
1	4	CM-SP6	.250 x 1.00 x 3.00" SQUARE HOLE SPACER
2	4	1/2-13 x 1 1/2	CARRIAGE BOLT
3	4	HFN 1213	HEX FLANGE NUT
4	2	1_2 FISHWIRE	1/2" FISHWIRE

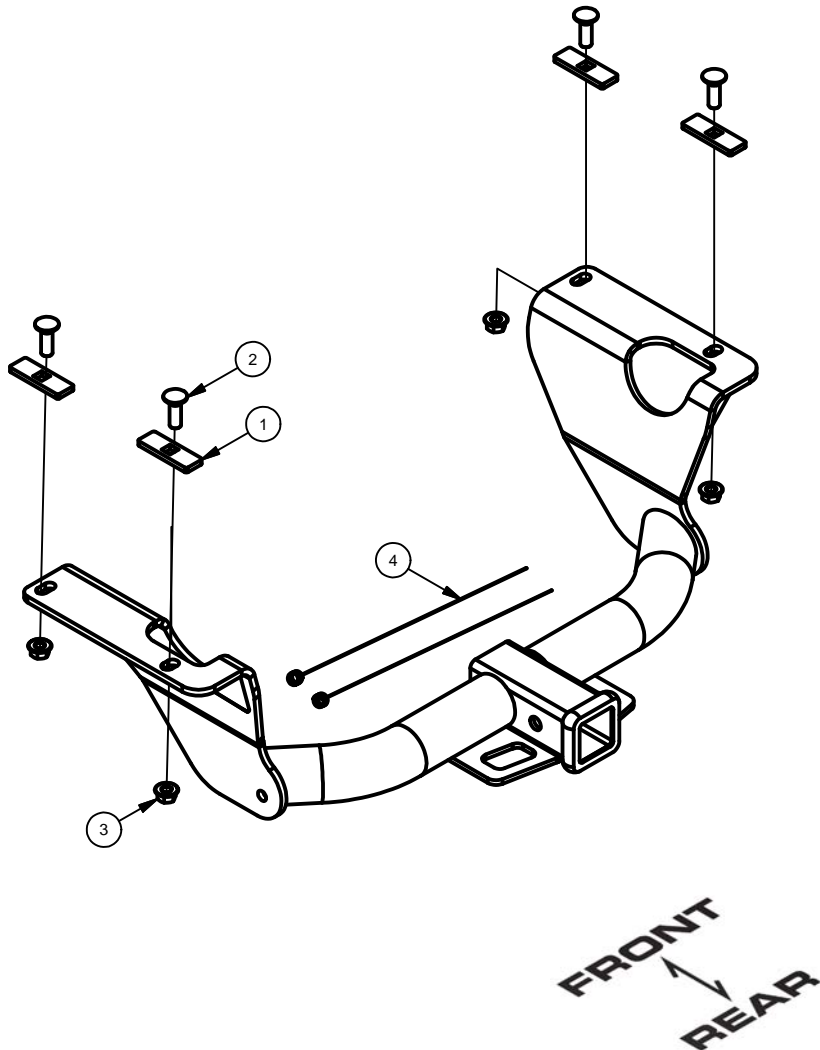

1. Remove (2) rearmost rubber isolators from exhaust muffler. One isolator is located towards outside of vehicle and one is located towards inside of vehicle.



2. Remove (1) rubber isolator from exhaust tube forward of muffler.



RUBBER ISOLATOR REMOVAL DIAGRAM

This technique can be used if an Exhaust Hanger Removal Pliers is not available.

Using a 5/8" open end wrench, slide the wrench up to the rubber isolator, cradling the hanger rod as shown. Next place the flat edge of a pry bar between the wrench and the hanger stop or hanger rod. Then simply rotate the pry bar toward the wrench to remove the rubber isolator.

Note: Using a spray lubricant or soapy water on the hanger rod and the rubber isolator helps removal.

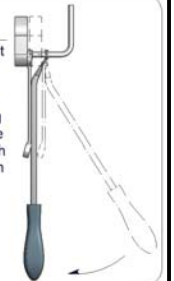

INSTALLATION WALKTHROUGH:

3. Use wire to tie up exhaust and prevent damage to exhaust tube.



4. Remove (4) screws from vehicle heat shield with 10mm socket. Remove heat shield from vehicle. Save screws for reinstallation in Step 13. Save heat shield for trimming and reinstallation.



5. Trim heat shield with aviation shears according to diagram.

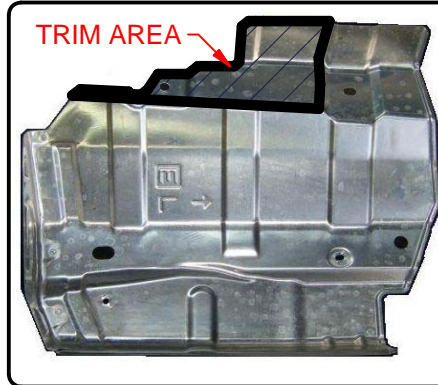

6. Remove (4) rubber plugs from frame rails. (2) plugs per frame rail. Return plugs to customer.



INSTALLATION WALKTHROUGH:

7. Enlarge front (2) holes where rubber plugs were removed in Step 6 with die grinder. Enlarge only enough to allow CM-SP6 spacers and 1/2" carriage bolts to pass through.

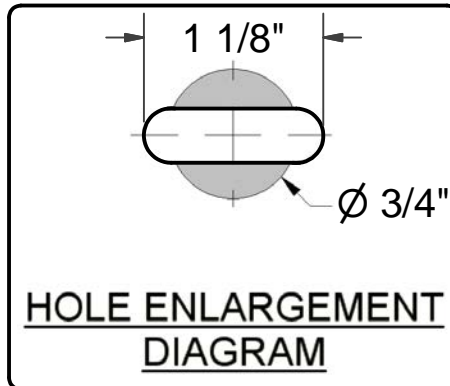

8. Fishwire 1/2" carriage bolts and CM-SP6 spacers through enlarged holes and out rear mounting holes using supplied fishwire tools.

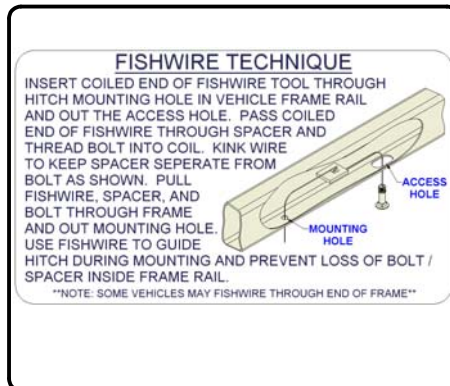

9. Raise hitch into position and secure hitch to vehicle with 1/2" hex flange nuts on fishwired bolts from Step 8. Only hand tighten bolts at this time with 3/4" socket.



10. Center hitch on vehicle. Using the hitch as a template, drill front (2) holes in frame rails. Drill one hole per frame rail using a 17/32" drill bit

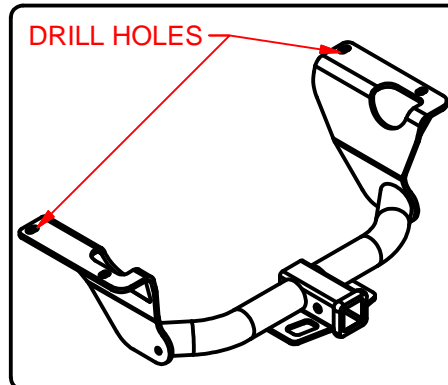

INSTALLATION WALKTHROUGH:

11. Fishwire 1/2" carriage bolts and CM-SP6 spacers through enlarged holes and out front mounting holes using supplied fishwire tools.

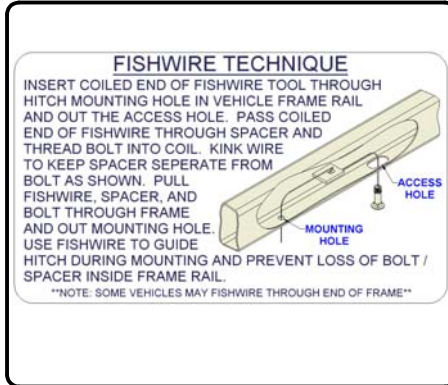

12. Secure hitch to vehicle with 1/2" hex flange nuts on fishwired bolts from Step 11. Only hand tighten bolts at this time with 3/4" socket.



13. Reinstall trimmed heat shield with (3) screws saved from Step 4. Use 10mm socket to tighten heat shield screws.

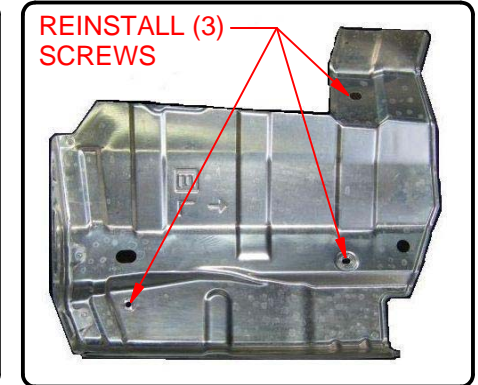

14. Torque 1/2" hardware to 110 lb-ft.

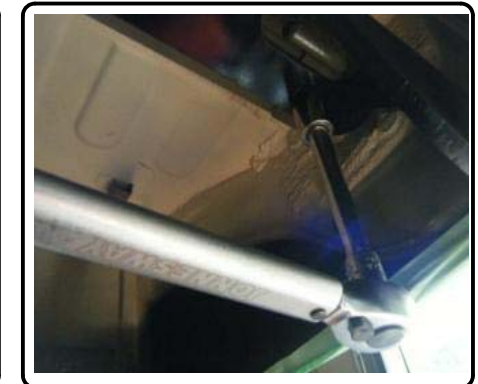

INSTALLATION WALKTHROUGH:

15. Reattach (2) rubber isolators on vehicle muffler.



16. Reattach (1) rubber isolators on vehicle exhaust tube forward of muffler. Remove wire previously holding up exhaust.



13158

SUBARU LEGACY

GROSS LOAD CAPACITY WHEN USED AS A WEIGHT CARRYING HITCH: 4,000 LBS. TRAILER WEIGHT & 600 LBS. TONGUE WEIGHT.

DO NOT EXCEED VEHICLE MANUFACTURER'S RECOMMENDED TOWING CAPACITY.

WARNING: ALL NON-TRAILER LOADS APPLIED TO THIS PRODUCT MUST BE SUPPORTED BY AUXILIARY STABILIZING STRAPS.

** FAILURE TO PROPERLY SUPPORT NON-TRAILER LOADS WILL VOID PRODUCT WARRANTY**

Parts List				
ITEM	QTY	PART NUMBER	DESCRIPTION	
2	4	1/2-13 x 1 1/2	CARRIAGE BOLT	
1	4	CM-SP6	.250 x 1.00 x 3.00" SQUARE HOLE SPACER	
3	4	HFN 1213	HEX FLANGE NUT	
4	2	1_2 FISHWIRE	1/2" FISHWIRE	

TOOLS REQUIRED
10 AND 3/4" SOCKETS
8" EXTENSION
SOCKET WRENCH
TORQUE WRENCH
DRILL AND 17/32" BIT
ROTARY TOOL / CARBIDE BIT
TIN SNIPS / FILE

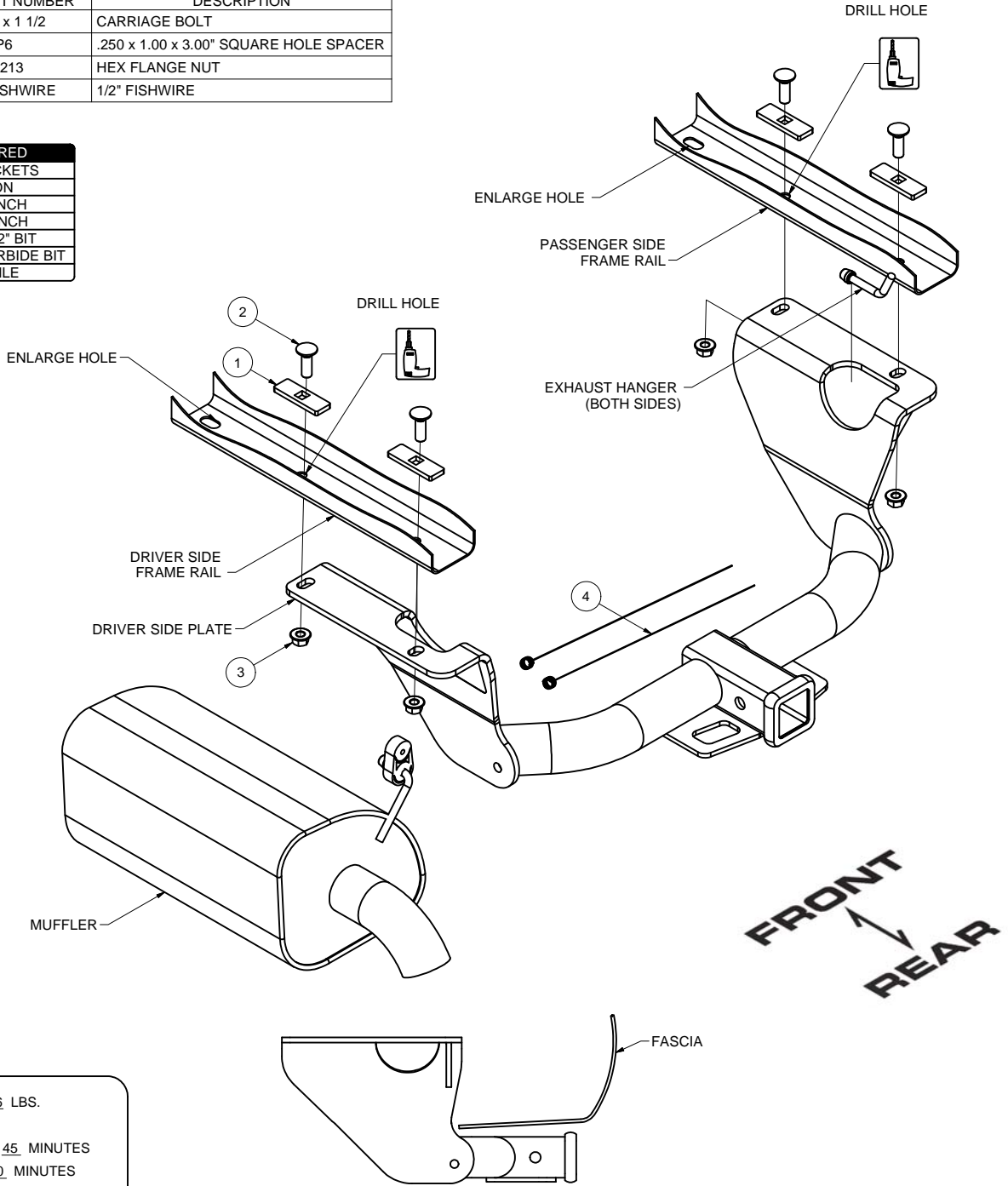

HITCH WEIGHT: .36 LBS.
INSTALL TIME
 PROFESSIONAL: .45 MINUTES
 NOVICE (DIY): .90 MINUTES
INSTALL NOTES:
 - DRILLING REQUIRED
 - FISHWIRE HARDWARE
 - LOWER EXHAUST
 - TRIM HEAT SHIELD

INSTALLED HITCH POSITION

PERIODICALLY CHECK THIS RECEIVER HITCH TO ENSURE THAT ALL FASTENERS ARE TIGHT AND THAT ALL STRUCTURAL COMPONENTS ARE SOUND.

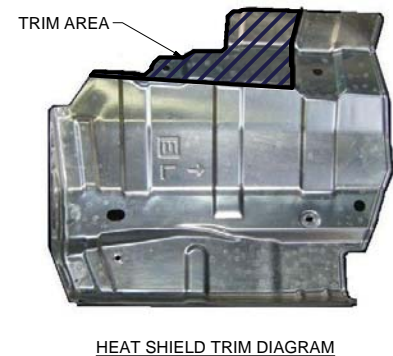
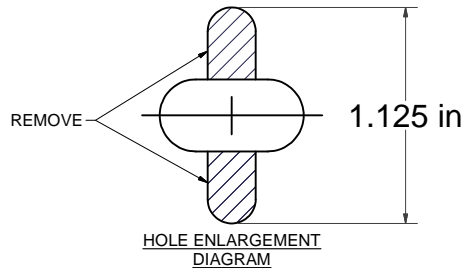
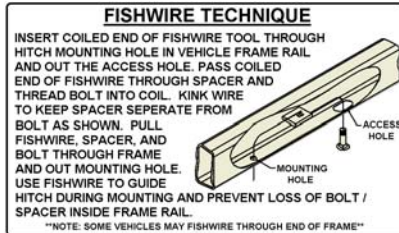

INSTALLATION STEPS

1. Lower the exhaust by removing two (2) rubber exhaust isolators per muffler and one (1) isolator per exhaust tube from the frame mounted hangers. (See RUBBER ISOLATOR REMOVAL DIAGRAM.)
2. Tie up exhaust with wire high enough to avoid damaging exhaust tubes.
3. Remove the muffler heat shield(s) by removing four (4) screws per heat shield. Save screws for reinstallation in Step 14. Save heat shield for trimming and reinstallation.
4. Trim heat shield to clear hitch side plates. (See HEAT SHIELD TRIM DIAGRAM.)
5. Remove two (2) rubber plugs from each frame rail. Return plugs to customer.
6. Enlarge front hole in each frame rail to allow the 1/2" carriage bolt and CM-SP6 spacer to be inserted into frame rail. (See HOLE ENLARGEMENT DIAGRAM.)
7. Fishwire 1/2" carriage bolts and CM-SP6 spacers through enlarged holes and out rear mounting holes in each frame rail. (See FISHWIRE TECHNIQUE diagram.)
8. Raise the hitch into position.
9. Center the hitch on vehicle and loosely secure hitch to vehicle with 1/2" hex flange nuts.
10. Using hitch as a template, mark and drill front holes in frame rails.
11. Fishwire 1/2" carriage bolts and CM-SP6 spacers through enlarged holes and out drilled holes.
12. Secure 1/2" hardware from Step 11 with 1/2" hex flange nuts.
13. Torque 1/2" hardware to 110 lb-ft.
14. Reinstall the heat shield with screws saved from Step 3.
15. Raise the exhaust and reinstall rubber isolators.

PERIODICALLY CHECK THIS RECEIVER HITCH TO ENSURE THAT ALL FASTENERS ARE TIGHT AND THAT ALL STRUCTURAL COMPONENTS ARE SOUND.