

YEARS: 2015

MAKE: KIA

MODEL: SEDONA

STYLE: VAN

**WARNING: NEVER EXCEED YOUR VEHICLE MANUFACTURER'S RECOMMENDED TOWING CAPACITY**

**WEIGHT CARRYING:**  
 TRAILER WEIGHT: 4,000 LBS.  
 TONGUE WEIGHT: 400 LBS.

**WEIGHT DISTRIBUTION:**  
 TRAILER WEIGHT: 4,000 LBS.  
 TONGUE WEIGHT: 400 LBS.

**PRO INSTALL TIME: 30 MIN.**  
**NOVICE INSTALL TIME: 60 MIN.**

IF YOU ARE HESITANT TO UNDERTAKE THIS TASK ON YOUR OWN, CONTACT AN AUTHORIZED CURT INSTALLER FOR ADDITIONAL ASSISTANCE.

**INSTALLATION TIPS:**

- BEFORE YOU BEGIN INSTALLATION, READ ALL INSTRUCTIONS THOROUGHLY.
- TO EASE INSTALLATION, 2 PEOPLE MAY BE REQUIRED.
- USING PROPER TOOLS WILL GREATLY IMPROVE THE QUALITY OF THE INSTALL AND REDUCE THE TIME REQUIRED.



**INSTALLATION REQUIRES:**

SAFETY GLASSES	WIRE PIPE BRUSH	SPRAY LUBRICANT
SCREW DRIVER	RATCHET	12" SOCKET EXTENSION
19mm SOCKET	TORQUE WRENCH	

**LEVEL OF DIFFICULTY: EASY**

EASY	MODERATE	CHALLENGING
		LOWER EXHAUST
		WELDNUT CLEANING
		PART REMOVAL
		NO DRILLING

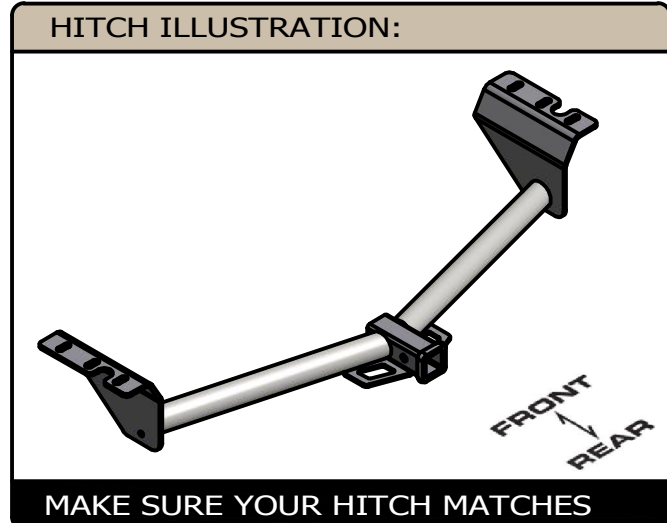

# INSTALLATION WALKTHROUGH:

Parts List			
ITEM	QTY	PART NUMBER	DESCRIPTION
1	6	M12-1.25 x 35mm	HEX BOLT
2	6	1/2"	CONICAL TOOTHED WASHER

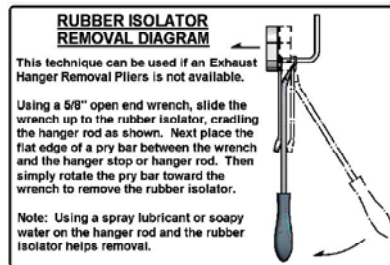
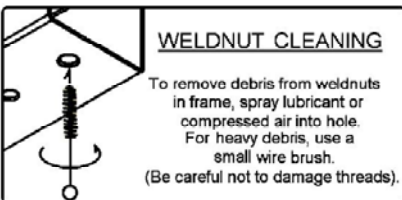
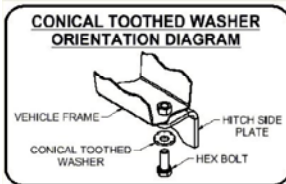
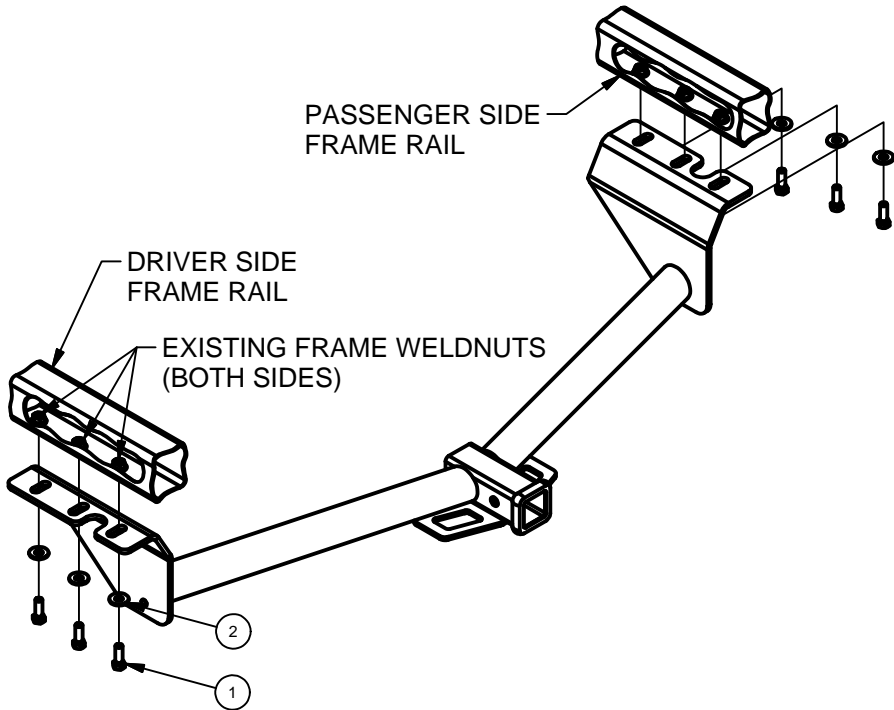

FRONT  
↓  
REAR

1.) Remove the driver side plastic panel, if equipped. Remove the plastic rivets and screws (6 places) securing the panel and return to owner.



2.) Lower the exhaust by removing the (4) rearmost rubber isolators from the muffler hangers. Support exhaust from underneath.

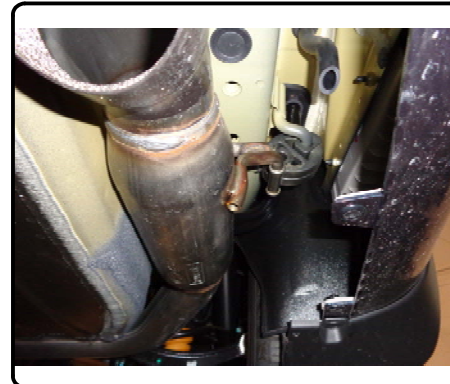

## INSTALLATION WALKTHROUGH:

Note: Weldnut cleaning may be required prior to hitch installation. Use a wire brush and/or spray lubricant to clean the weldnut threads.

3.) Raise hitch into position and loosely secure by installing M12 bolts and washers with a 19mm socket as shown.



4.) Torque all M12 hardware to 86 ft-lb. Reattach all exhaust hangers.

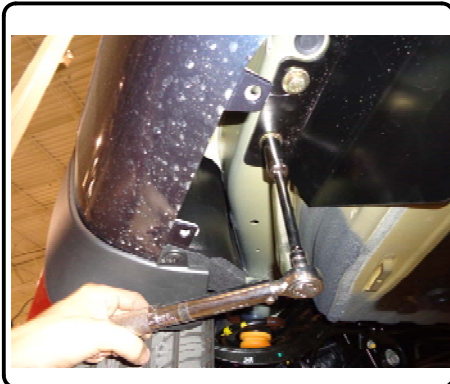

Installation complete



**13115****KIA SEDONA**

**GROSS LOAD CAPACITY WHEN USED AS A WEIGHT CARRYING HITCH: 4,000 LBS. TRAILER WEIGHT & 400 LBS. TONGUE WEIGHT.  
GROSS LOAD CAPACITY WHEN USED AS A WEIGHT DISTRIBUTION HITCH: 4,000 LBS. TRAILER WEIGHT & 400 LBS. TONGUE WEIGHT**

**\*\*\*DO NOT EXCEED VEHICLE MANUFACTURER'S RECOMMENDED TOWING CAPACITY.\*\*\***

Parts List

ITEM	QTY	PART NUMBER	DESCRIPTION
1	6	M12-1.25 x 35mm	HEX BOLT
2	6	1/2"	CONICAL TOOTHED WASHER

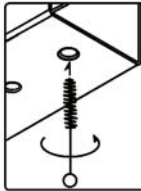
**WELDNUT CLEANING**

To remove debris from weldnuts in frame, spray lubricant or compressed air into hole. For heavy debris, use a small wire brush. (Be careful not to damage threads).

**RUBBER ISOLATOR REMOVAL DIAGRAM**

This technique can be used if an Exhaust Hanger Removal Pliers is not available.

Using a 5/8" open end wrench, slide the wrench up to the rubber isolator, cradling the hanger rod as shown. Next place the flat edge of a pry bar between the wrench and the hanger stop or hanger rod. Then simply rotate the pry bar toward the wrench to remove the rubber isolator.

Note: Using a spray lubricant or soapy water on the hanger rod and the rubber isolator helps removal.

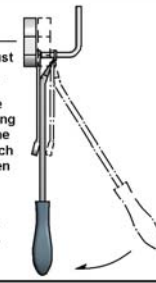
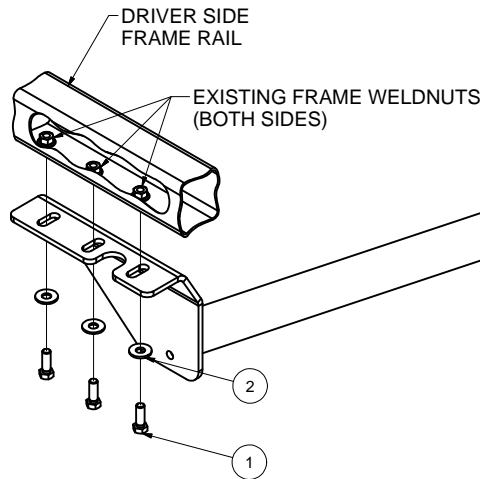
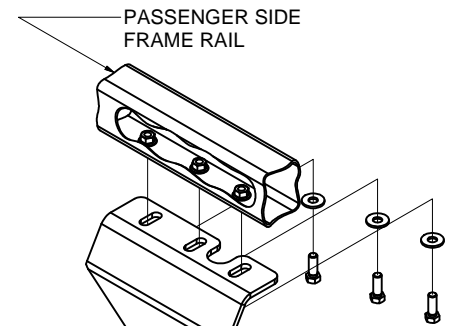
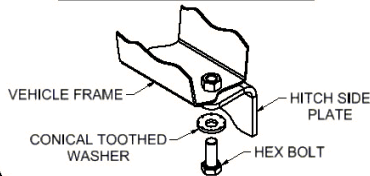
**CONICAL TOOTHED WASHER ORIENTATION DIAGRAM**

**FRONT**  
↑  
**REAR**

**TOOLS REQUIRED**

WIRE BRUSH  
SCREWDRIVER  
SPRAY LUBRICANT  
19mm SOCKET  
RATCHET  
SOCKET EXTENSION  
TORQUE WRENCH

HITCH WEIGHT: 43 LBS.

**INSTALL TIME**

PROFESSIONAL: 30 MINUTES

NOVICE (DIY): 60 MINUTES

**INSTALL NOTES:**

- WELDNUT CLEANING
- PART REMOVAL
- LOWER EXHAUST
- NO DRILLING

**INSTALLATION STEPS**

Note: Weldnut cleaning may be required prior to hitch installation. Use a wire brush and/or spray lubricant to clean the weldnut threads.

- 1.) Remove the driver side plastic panel, if equipped. Remove the plastic rivets and screws (6 places) securing the panel and return to owner.
- 2.) Lower the exhaust by removing the (4) rearmost rubber isolators from the muffler hangers. Support exhaust from underneath.
- 3.) Raise hitch into position and loosely secure by installing M12 bolts and washers with a 19mm socket as shown.
- 4.) Torque all M12 hardware to 86 ft-lb. Reattach all exhaust hangers.

PERIODICALLY CHECK THIS RECEIVER HITCH TO ENSURE THAT ALL FASTENERS ARE TIGHT AND THAT ALL STRUCTURAL COMPONENTS ARE SOUND.

Learn more about trailer hitches and towing we have.