

12335

DODGE JOURNEY



GROSS LOAD CAPACITY WHEN USED AS A WEIGHT CARRYING HITCH: 3,500 LBS. *TRAILER WEIGHT* & 350 LBS. TONGUE WEIGHT.  
**\*\*\*DO NOT EXCEED VEHICLE MANUFACTURER'S RECOMMENDED TOWING CAPACITY.\*\*\***

		Parts List	
ITEM	QTY	PART NUMBER	DESCRIPTION
1	2	CM-SP4	.250 x 1.50 x 3.00" SQUARE HOLE SPACER
2	6	HFN 1213	HEX FLANGE NUT
3	6	1/2-13 x 1 1/2	CARRIAGE BOLT
4	2	1_2 FISHWIRE	1/2" FISHWIRE
5	4	CM-SP12	.250 x 1.00 x 2.00" SQUARE HOLE SPACER
6	2	CM-SP38	1/2" WEDGE SPACER

TOOLS REQUIRED
RATCHET
3/4" SOCKET
TORQUE WRENCH
5/8" OPEN END WRENCH
SMALL PRY BAR

PASSENGER SIDE FRAME RAIL

FISHWIRE CARRIAGE BOLTS THROUGH SPACE BETWEEN THE BUMPER BEAM AND THE FRAME RAIL (FOR BOTH SIDES)

**FISHWIRE TECHNIQUE**

INSERT COILED END OF FISHWIRE TOOL THROUGH HITCH MOUNTING HOLE IN VEHICLE FRAME RAIL AND OUT THE ACCESS HOLE. PASS COILED END OF FISHWIRE THROUGH SPACER AND THREAD BOLT INTO COIL. KINK WIRE TO KEEP SPACER SEPARATE FROM BOLT AS SHOWN. PULL FISHWIRE, SPACER, AND BOLT THROUGH FRAME AND OUT MOUNTING HOLE. USE FISHWIRE TO GUIDE HITCH DURING MOUNTING AND PREVENT LOSS OF BOLT / SPACER INSIDE FRAME RAIL.

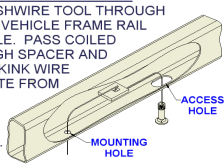

\*\*NOTE: SOME VEHICLES MAY FISHWIRE THROUGH END OF FRAME\*\*

**RUBBER ISOLATOR REMOVAL DIAGRAM**

This technique can be used if an Exhaust Hanger Removal Pliers is not available.

Using a 5/8" open end wrench, slide the wrench up to the rubber isolator, cradling the hanger rod as shown. Next place the flat edge of a pry bar between the wrench and the hanger stop or hanger rod. Then simply rotate the pry bar toward the wrench to remove the rubber isolator.

Note: Using a spray lubricant or soapy water on the hanger rod and the rubber isolator helps removal.

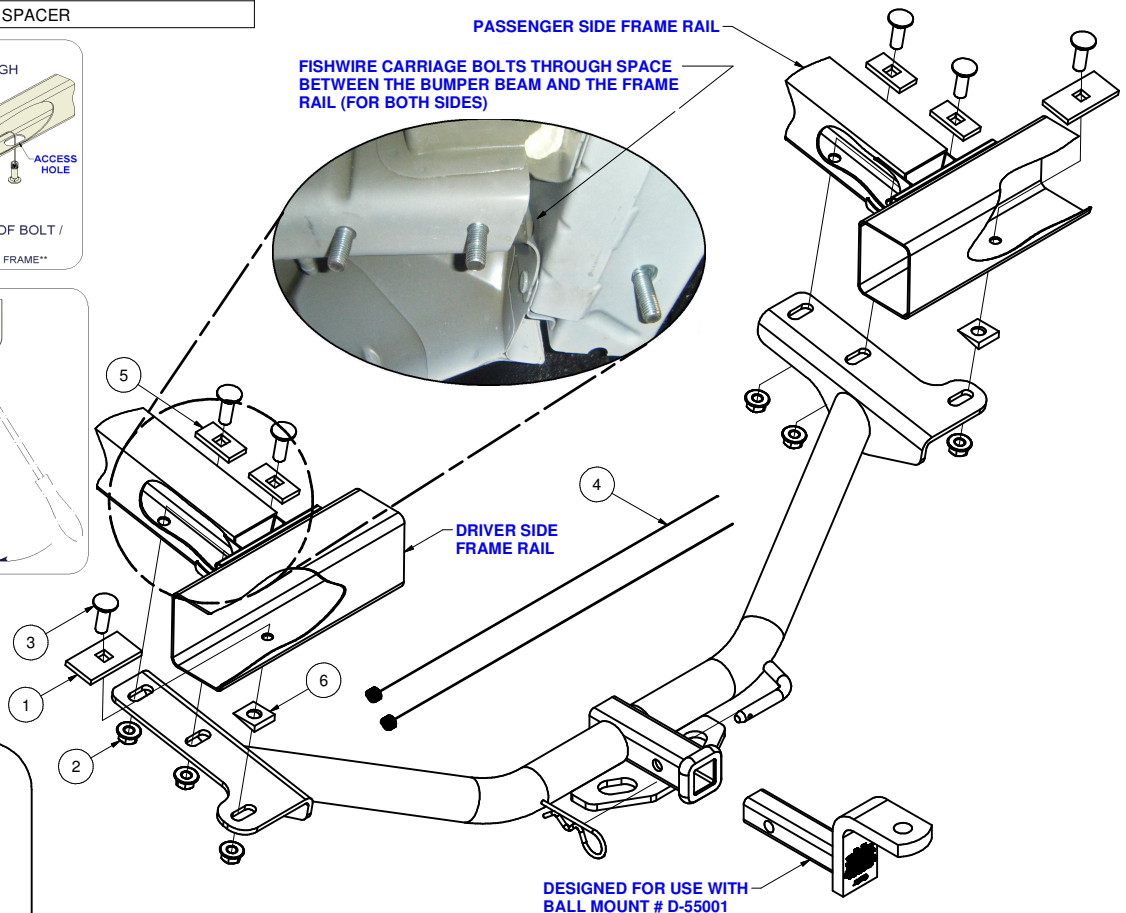
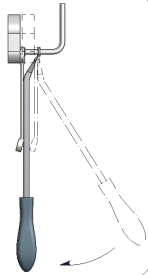

HITCH WEIGHT: 26 LBS.

INSTALL TIME: 45 MINUTES

INSTALL NOTES:

- LOWER EXHAUST
- FISHWIRE HARDWARE

**INSTALLATION STEPS**

- 1) Lower exhaust by removing (4) rubber isolators. Use an open end wrench (5/8" or larger) and a pry bar as shown above to remove isolators. Note: Spraying a lubricant or soapy water on the metal hanger rod and the rubber isolator helps removal.
- 2) Fishwire the carriage bolts and small square hole spacers through the space between the bumper beam and the end of the frame rail for both sides.
- 3) Fishwire the remaining carriage bolts and large spacers through the bumper beam and into position.
- 4) Raise hitch into position with the "wedge" shaped spacers between as shown and secure with hex flange nuts.
- 5) Torque all 1/2" fasteners to 110 lb-ft.
- 6) Raise exhaust back into position and reinstall the (4) rubber isolators removed in step 1.  
 Note: re-apply lubricant or soapy water to ease installation.

**PERIODICALLY CHECK THIS RECEIVER HITCH TO ENSURE THAT ALL FASTENERS ARE TIGHT AND THAT ALL STRUCTURAL COMPONENTS ARE SOUND.**

Find more CURT products on our website.

Learn more about trailer hitches and towing we have.