

YEARS: 2013-PRESENT

MAKE: FORD

MODEL: ESCAPE

STYLE: SUV







WARNING: NEVER EXCEED YOUR VEHICLE MANUFACTURER'S RECOMMENDED TOWING CAPACITY

WEIGHT CARRYING:
 TRAILER WEIGHT: 3,500 LBS.
 TONGUE WEIGHT: 350 LBS.

PRO INSTALL TIME: 40 MIN.
NOVICE INSTALL TIME: 80 MIN.

IF YOU ARE HESITANT TO UNDERTAKE THIS TASK ON YOUR OWN, CONTACT AN AUTHORIZED CURT INSTALLER FOR ADDITIONAL ASSISTANCE.





INSTALLATION REQUIRES:

 TORQUE WRENCH	 RATCHET	 6" SOCKET EXTENSION
 13mm 10mm 11/16" SOCKET	 DIE GRINDER	 AVIATION SHEARS
 SAFETY GLASSES		

INSTALLATION TIPS:

- BEFORE YOU BEGIN INSTALLATION, READ ALL INSTRUCTIONS THOROUGHLY.
- TO EASE INSTALLATION, 2 PEOPLE MAY BE REQUIRED.
- USING PROPER TOOLS WILL GREATLY IMPROVE THE QUALITY OF THE INSTALL AND REDUCE THE TIME REQUIRED.

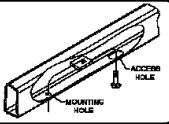
LEVEL OF DIFFICULTY: MODERATE

EASY	MODERATE	CHALLENGING
	- TEMPORARILY LOWER EXHAUST	
	- TRIM HEAT SHIELD	
	- FISHWIRE HARDWARE	
	- ENLARGE ACCESS HOLE	

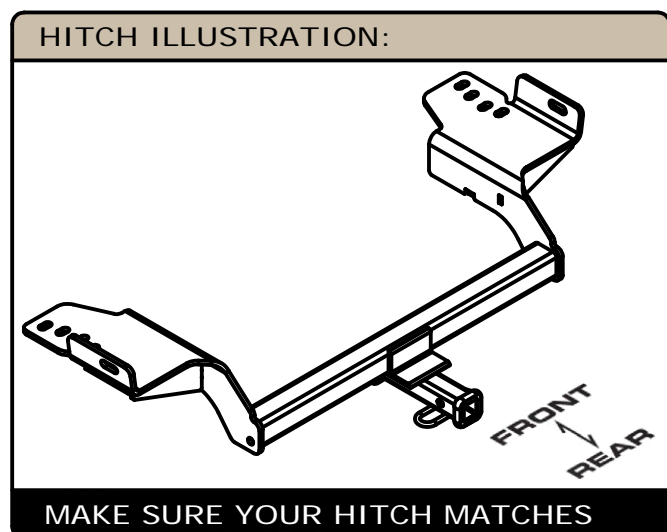

INSTALLATION WALKTHROUGH:

Parts List

ITEM	QTY	PART NUMBER	DESCRIPTION
1	6	7_16 FISHWIRE	7/16" FISHWIRE
2	6	7/16-14 x 1 1/2	CARRIAGE BOLT
3	6	CM-SP7	.250 x 1.00 x 2.00" SQUARE HOLE SPACER
4	6	7/16-14	HEX FLANGE NUT
5	4	5/16"	WASHER
6	4	M8 - 1.25 x 30 HEX BOLT	HEX HEAD BOLT

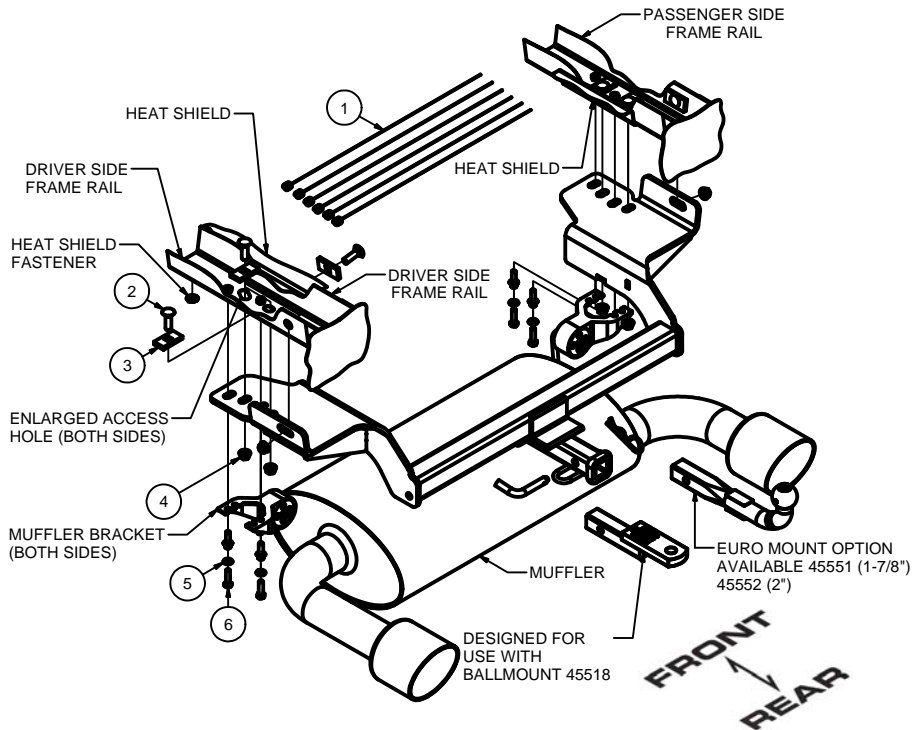

RUBBER ISOLATOR REMOVAL DIAGRAM

This technique can be used if an Exhaust Hanger Removal Pliers is not available.

Using a 5/8" open end wrench, slide the wrench up to the rubber isolator, cradling the hanger rod as shown. Next place the flat edge of a pry bar between the wrench and the hanger stop or hanger rod. Then simply rotate the pry bar toward the wrench to remove the rubber isolator.

Note: Using a spray lubricant or soapy water on the hanger rod and the rubber isolator helps removal.

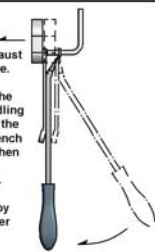

WELDNUT CLEANING

To remove debris from weldnuts in frame, spray lubricant or compressed air into hole. For heavy debris, use a small wire brush. (Be careful not to damage threads).

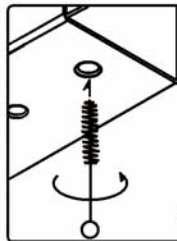

1. Lower exhaust by removing the (4) 8mm bolts from the muffler brackets and the forward rubber isolator. Return the (4) 8mm bolts to the owner.

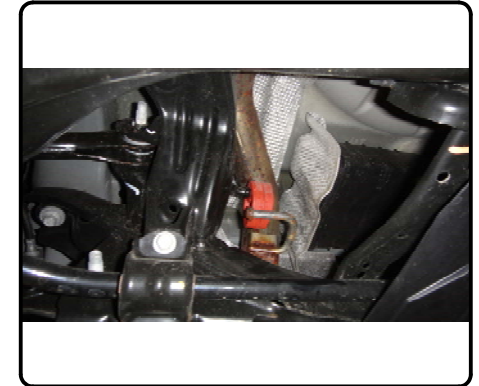

2. Remove the (1) fastener securing the heat shield to the bottom of the driver side frame rail. Trim the portion of the heat shield covering the mounting areas of the driver and passenger side frame rails, see trim diagram. After trimming re-attach the heat shield to the bottom of the driver side.

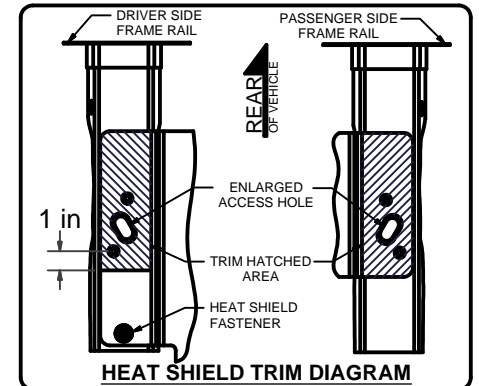

INSTALLATION WALKTHROUGH:

3. Enlarge the access holes to allow 7/16" carriage bolts to pass through. Fishwire the 7/16" carriage bolts and SP7 spacers in the enlarged access hole and out the (2) rear-most mounting holes, both sides. Reverse fishwire the 7/16" carriage bolt and SP7 spacer in the enlarged access hole, both sides. **Note:** Leave fishwires attached to prevent loss into the frame rails. Push the side fasteners back into the frame rail prior to raising the hitch into position.



4. Slide the hitch in from the rear passenger side of the vehicle over the exhaust and into position. **Note:** Feed the fishwires through the mounting holes while raising the hitch.

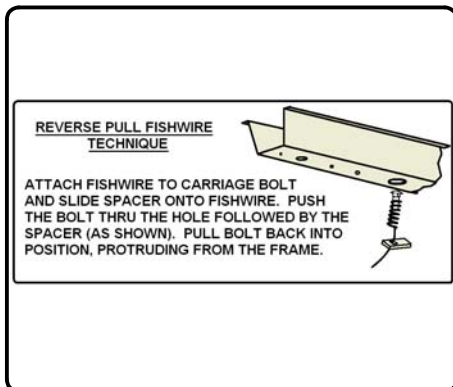
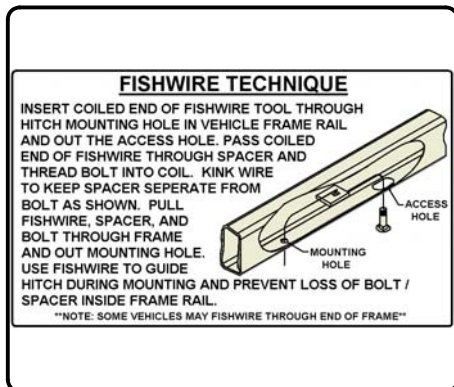

5. Remove the fishwires from the carriage bolts in the bottom of the frame rails and loosely secure the hitch with 7/16" flange nuts. Pull the fishwires through the side mounting holes and loosely secure them with 7/16" flange nuts. Re-attach the muffler brackets to the bottom of the hitch into the original mounting holes using the provided M8-1.25 hex bolts and 5/16" washers.



6. Torque all 7/16" hardware to 70 ft-lbs. Torque all M8 hardware to 23 ft-lbs. Re-attach rubber isolator removed in Step 1.

Installation complete



12111

FORD ESCAPE

GROSS LOAD CAPACITY WHEN USED AS A WEIGHT CARRYING HITCH: 30 LBS. TRAILER WEIGHT & 35 LBS. TONGUE WEIGHT.
 DO NOT EXCEED VEHICLE MANUFACTURER'S RECOMMENDED TOWING CAPACITY.
WARNING: ALL NON-TRAILER LOADS APPLIED TO THIS PRODUCT MUST BE SUPPORTED BY 18050 STABILIZING STRAPS.
 ** FAILURE TO PROPERLY SUPPORT NON-TRAILER LOADS WILL VOID PRODUCT WARRANTY**

Parts List			
ITEM	QTY	PART NUMBER	DESCRIPTION
1	6	7_16 FISHWIRE	7/16" FISHWIRE
2	6	7/16-14 x 1 1/2	CARRIAGE BOLT
3	6	CM-SP7	.250 x 1.00 x 2.00" SQUARE HOLE SPACER
4	6	7/16-14	HEX FLANGE NUT
5	4	5/16"	WASHER
6	4	M8 - 1.25 x 30 HEX BOLT	HEX HEAD BOLT

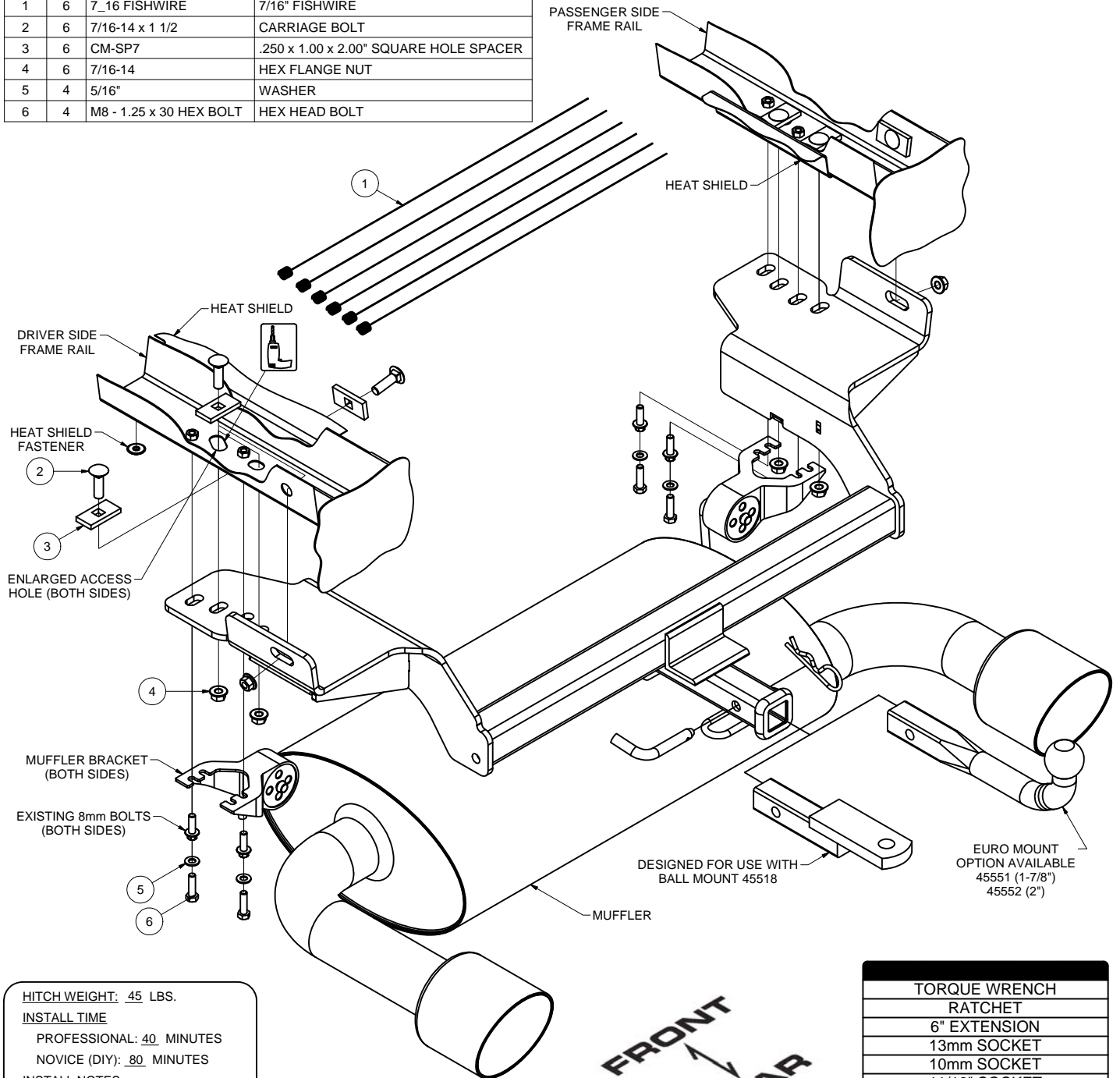

HITCH WEIGHT: 45 LBS.
INSTALL TIME
 PROFESSIONAL: 40 MINUTES
 NOVICE (DIY): 80 MINUTES
INSTALL NOTES:
 - HOLE ENLARGEMENT
 - FISHWIRE HARDWARE
 - TRIM HEAT SHIELD
 - TEMPORARILY LOWER EXHAUST

TORQUE WRENCH
RATCHET
6" EXTENSION
13mm SOCKET
10mm SOCKET
11/16" SOCKET
DIE GRINDER
SHEARS
SAFETY GLASSES

PERIODICALLY CHECK THIS RECEIVER HITCH TO ENSURE THAT ALL FASTENERS ARE TIGHT AND THAT ALL STRUCTURAL COMPONENTS ARE SOUND.

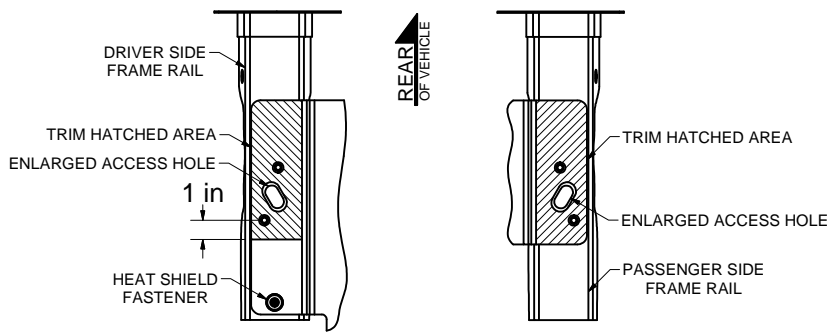
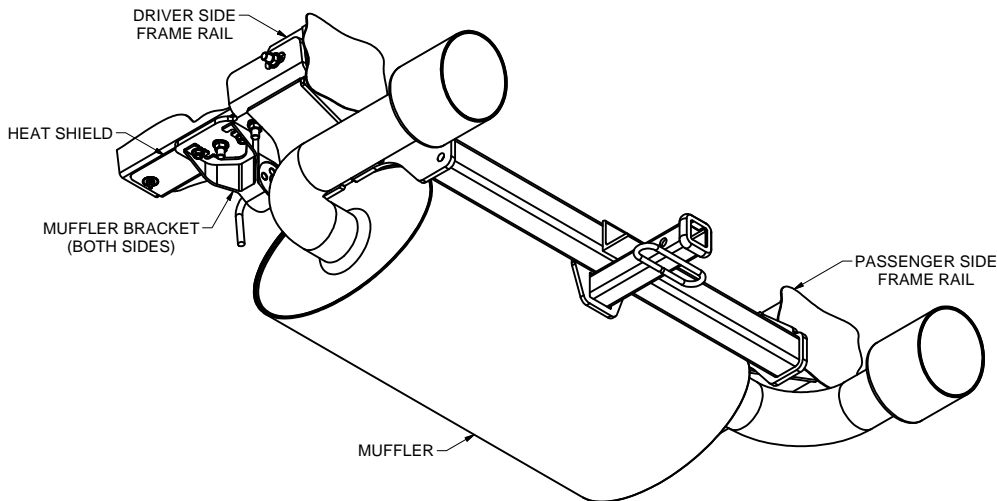
**HEAT SHIELD TRIM DIAGRAM****INSTALLED HITCH****RUBBER ISOLATOR REMOVAL DIAGRAM**

This technique can be used if an Exhaust Hanger Removal Pliers is not available.

Using a 5/8" open end wrench, slide the wrench up to the rubber isolator, cradling the hanger rod as shown. Next place the flat edge of a pry bar between the wrench and the hanger stop or hanger rod. Then simply rotate the pry bar toward the wrench to remove the rubber isolator.

Note: Using a spray lubricant or soapy water on the hanger rod and the rubber isolator helps removal.

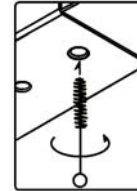
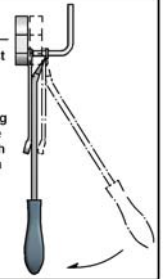
**WELDNUT CLEANING**

To remove debris from weldnuts in frame, spray lubricant or compressed air into hole. For heavy debris, use a small wire brush. (Be careful not to damage threads).

FISHWIRE TECHNIQUE

INSERT COILED END OF FISHWIRE TOOL THROUGH HITCH MOUNTING HOLE IN VEHICLE FRAME RAIL AND OUT THE ACCESS HOLE. PASS COILED END OF FISHWIRE THROUGH SPACER AND THREAD BOLT INTO COIL. KINK WIRE TO KEEP SPACER SEPARATE FROM BOLT AS SHOWN. PULL FISHWIRE, SPACER, AND BOLT THROUGH FRAME AND OUT MOUNTING HOLE. USE FISHWIRE TO GUIDE HITCH DURING MOUNTING AND PREVENT LOSS OF BOLT / SPACER INSIDE FRAME RAIL.

"NOTE: SOME VEHICLES MAY FISHWIRE THROUGH END OF FRAME"

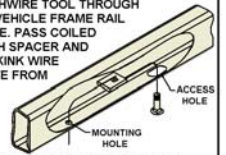
**REVERSE PULL FISHWIRE TECHNIQUE**

ATTACH FISHWIRE TO CARRIAGE BOLT AND SLIDE SPACER ONTO FISHWIRE. PUSH THE BOLT THRU THE HOLE FOLLOWED BY THE SPACER (AS SHOWN). PULL BOLT BACK INTO POSITION, PROTRUDING FROM THE FRAME.

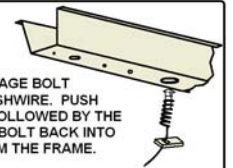
**INSTALLATION STEPS**

1. Lower exhaust by removing the (4) 8mm bolts from the muffler brackets and the forward rubber isolator. Return the (4) 8mm bolts to the owner. See Rubber Isolator Removal Diagram
2. Remove the (1) fastener securing the heat shield to the bottom of the driver side frame rail. Trim the portion of the heat shield covering the mounting areas of the driver and passenger side frame rails, see trim diagram. After trimming re-attach the heat shield to the bottom of the driver side.
3. Enlarge the access holes to allow 7/16" carriage bolts to pass through.
4. Fishwire the 7/16" carriage bolts and SP7 spacers in the enlarged access hole and out the (2) rear-most mounting holes, both sides. Reverse fishwire the 7/16" carriage bolt and SP7 spacer in the enlarged access hole, both sides. See Fishwire Diagrams. **Note:** Leave fishwires attached to prevent loss into the frame rails. Push the side fasteners back into the frame rail prior to raising the hitch into position.
5. Slide the hitch in from the rear passenger side of the vehicle over the exhaust and into position. **Note:** Feed the fishwires through the mounting holes while raising the hitch.
6. Remove the fishwires from the carriage bolts in the bottom of the frame rails and loosely secure the hitch with 7/16" flange nuts. Pull the fishwires through the side mounting holes and loosely secure them with 7/16" flange nuts.
7. Re-attach the muffler brackets to the bottom of the hitch into the original mounting holes using the provided M8-1.25 hex bolts and 5/16" washers.
8. Torque all 7/16" hardware to 70 ft-lbs. Torque all M8 hardware to 23 ft-lbs.
9. Re-attach rubber isolator removed in Step 1.

PERIODICALLY CHECK THIS RECEIVER HITCH TO ENSURE THAT ALL FASTENERS ARE TIGHT AND THAT ALL STRUCTURAL COMPONENTS ARE SOUND.