



Safety glasses should be worn at all times while installing this product.

YEARS: 2016

MAKE: KIA

MODEL: SOUL

STYLE: HATCHBACK





WARNING: NEVER EXCEED YOUR VEHICLE MANUFACTURER'S RECOMMENDED TOWING CAPACITY

WEIGHT CARRYING:
 TRAILER WEIGHT: 2000 LBS.
 TONGUE WEIGHT: 200 LBS.

PRO INSTALL TIME: 30 MIN.
NOVICE INSTALL TIME: 60 MIN.

IF YOU ARE HESITANT TO UNDERTAKE THIS TASK ON YOUR OWN, CONTACT AN AUTHORIZED CURT INSTALLER FOR ADDITIONAL ASSISTANCE.



INSTALLATION REQUIRES:

 SAFETY GLASSES	 SPRAY LUBRICANT	 RATCHET
 12" SOCKET EXTENSION	 10mm 17mm SOCKET	 TORQUE WRENCH
 SCREW DRIVER		

INSTALLATION TIPS:

- BEFORE YOU BEGIN INSTALLATION, READ ALL INSTRUCTIONS THOROUGHLY.
- TO EASE INSTALLATION, 2 PEOPLE MAY BE REQUIRED.
- USING PROPER TOOLS WILL GREATLY IMPROVE THE QUALITY OF THE INSTALL AND REDUCE THE

LEVEL OF DIFFICULTY: EASY

<i>EASY</i>	<i>MODERATE</i>	<i>CHALLENGING</i>
	LOWER EXHAUST	
	USE EXISTING WELDNUTS	
	NO DRILLING REQUIRED	

VEHICLE PHOTO:



REPRESENTATIVE PHOTO

HITCH ILLUSTRATION:

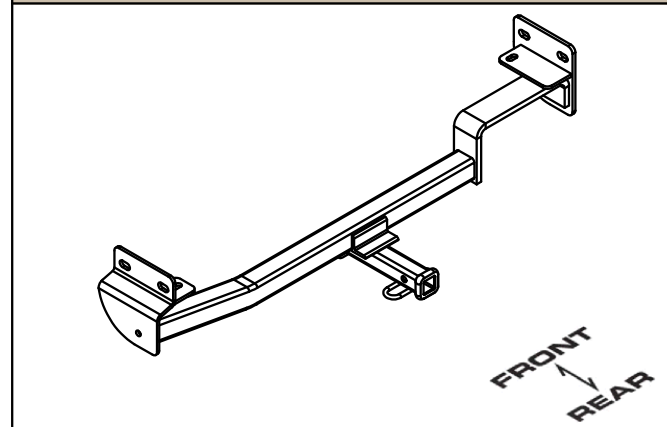

MAKE SURE YOUR HITCH MATCHES

INSTALLATION WALKTHROUGH:

Parts List			
ITEM	QTY	PART NUMBER	DESCRIPTION
1	6	M10 - 1.25 x 30	HEX BOLT
2	6	7/16"	CONICAL TOOTHED WASHER

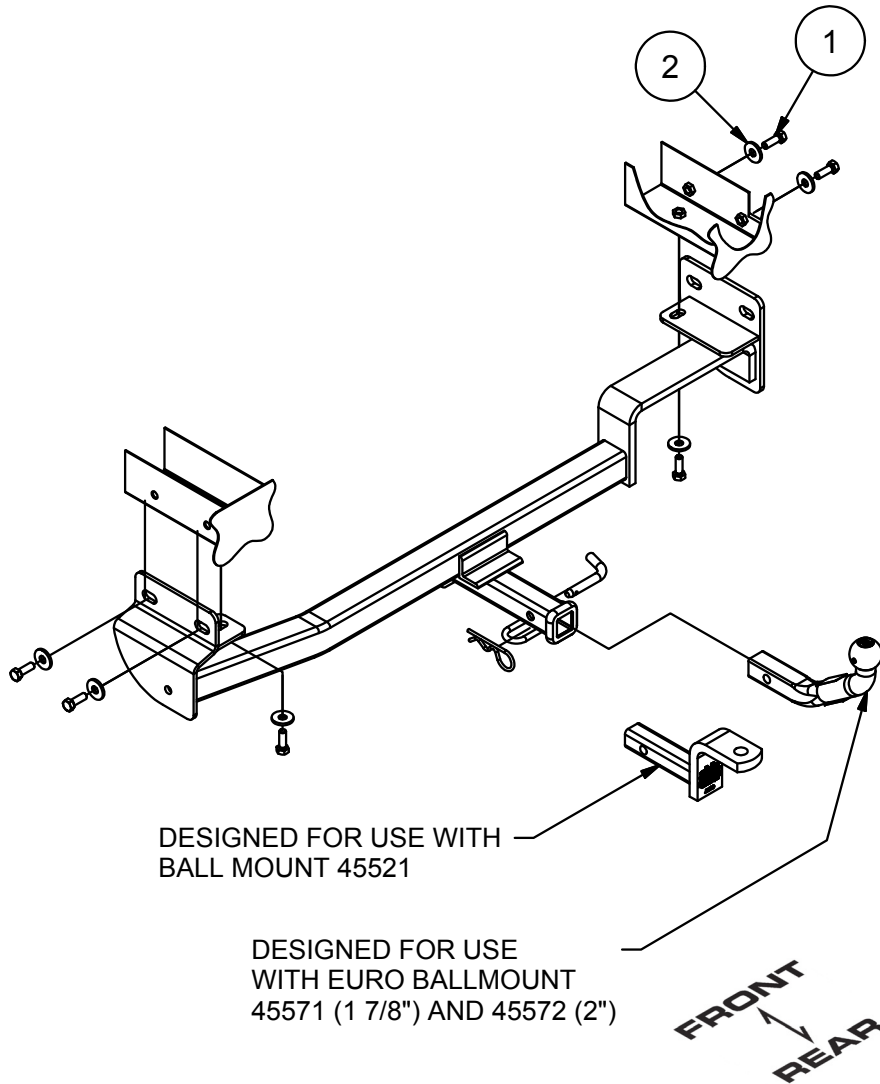

Note: Be careful around the brake lines and the canister.

1. Remove the (3) Phillips screws and (2) Phillips push pins from each fender well. Pull the wheel well liner gently away from the car and gently separate the wheel well liner from fender to allow for hitch installation.

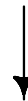

2. Lower exhaust by removing rubber exhaust hangers from hanger rods in (1) location on the passenger side.



INSTALLATION WALKTHROUGH:

3. Optional - For ease of install.

Remove the (3) nuts that hold on the canister. Use a flat blade screwdriver to disengage the spring clips on the canister for removal. Carefully suspend canister during hitch installation.



4. Raise the hitch into position and align the holes in the side plates with the holes in the sides of the frame rails. Secure the hitch with 7/16" conical toothed washers and M10 hex bolts into each weldnut
Torque all M10 hex bolts to 48 ft-lbs.

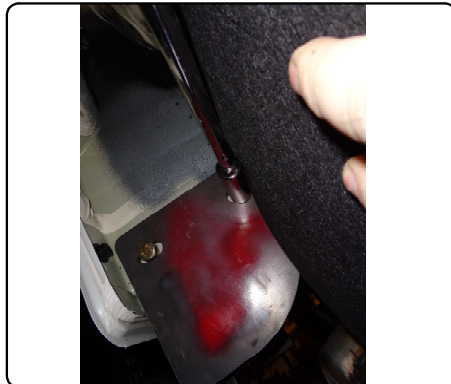

5. Raise exhaust back into position and secure to vehicle hanger.

If Step 3 was executed:

Raise canister back into position and reattach using factory hardware.

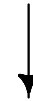

6. Reattach wheel well liners and splash shields with factory hardware. Trimming of the drivers wheel well liner may be required to give the driver side plate more clearance.

Installation Complete

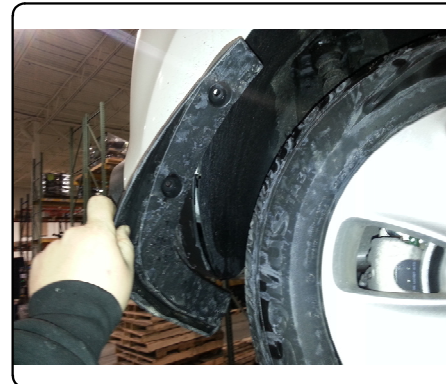

TOWING SAFETY INFORMATION

Gross Trailer Weight / GTW

The Gross Trailer Weight is the weight of the trailer & cargo. Measure this by putting the fully loaded trailer on a vehicle scale.

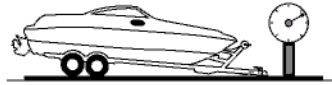

Tongue Weight / TW

The downward force that is exerted on the hitch ball by the coupler. The tongue weight will vary depending on where the load is positioned in relationship to the trailer axle(s). To measure the tongue weight, use either a commercial scale or a bathroom scale with the coupler at towing height. When using a bathroom scale with heavier tongue weights, use the method shown and multiply the scale reading by 3.

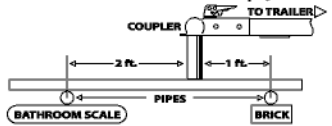

Weight Carrying / WC

The total weight of both the trailer and the cargo inside. Never exceed the weight capacity of your trailer hitch.

Weight Distribution / WD

Used to balance the weight of the cargo between the front and rear wheels throughout the trailer, allowing for better steering, braking, and level riding.



Sway Control

A device used to reduce the lateral movements of the trailer that are caused by the wind. This works in conjunction with a weight distribution hitch. Do not use this on a class 1 or 2 hitch, or with surge brakes.

How Much Can You Safely Tow?

TONGUE WEIGHT (lb)	1000	2000	3000	4000	5000	6000	7000	8000	10,000	12,000
Tongue weight should be about 10 to 15 percent of the gross trailer weight.										
CLASS 1										
CLASS 2										
CLASS 3										
CLASS 4										
CLASS 5										
TRAILER TYPE										
Camper	11'	12'	13'	14'	15'	16'				
lbs.	1100	1200	1300	1400	1500	1600				
Vacation	18'	19'	20'	21'	22'	24'	26'	28'	30'	32'
lbs.	2100	2400	2700	3000	3300	3600	3900	4200	4500	4800
Vacation	18'	19'	20'	21'	22'	24'	26'	28'	30'	32'
lbs.	2800	3200	3600	4000	4400	4800	5200	5600	6000	6400
5th Wheel										

Refer to owner's manual for towing capabilities and limitations.

Ball Mount

The ball mount is placed inside the opening of the receiver hitch which is mounted to the vehicle. Make sure a hitch pin and clip is properly securing the ball mount to the receiver hitch before you begin towing.

- A: Rise. B: Drop. C: Hole Size. D: Length.

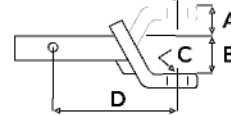

Trailer Ball

The connection from the hitch to the trailer. There are many factors that determine the correct hitch ball:

- Number one is the hitch ball's gross trailer weight rating.
- The mounting platform must be at least 3/8" thick.
- The hole diameter must not be more than 1/16" larger than the threaded shank.
- Every time you tow, check the nut and lock washer to make sure they are fastened securely.
- A: Ball Dia. B: Shank Length. C: Shank Dia. D: Shank Rise.

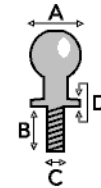

Coupler

The component that is placed over the trailer ball to connect the vehicle to the trailer. Be sure that the coupler size matches the size of the hitch ball and that the coupler handle is securely fastened. To determine what size hitch ball you need for your application you will need to know the size of coupler that is on the trailer. Be sure your coupler is properly adjusted to the ball you are using.

NOTE: For added security the use of safety devices such as Coupler Safety Pins and Locks is strongly recommended.

Safety Chains

Safety chains are a requirement and should be crossed under the tongue of the trailer so that the tongue will not drop to the road if it becomes separated from the hitch. Always leave enough slack so you can turn. Never allow the safety chains to drag on the ground and never attach the chains to the bumper.

Trailer Classification: Safety Chain Breaking Force - Minimum

Class 1: 2,000 lbs. (8.9 kN)

Class 2: 3,500 lbs. (15.6 kN)

Class 3: 5,000 lbs. (22.2 kN)

The strength rating of each length of safety chain or its equivalent and its attachments shall be equal to or exceed in minimum breaking force the GVWR (Gross Vehicle Weight Rating) of the trailer.

Electrical

Trailer lights, Electric Brakes, Break-away systems - Every time you tow, be sure to check that all components are working properly.

Wiring identification by color:

7-WAY						
6-WAY						
5-WAY						
4-WAY						
GREEN	YELLOW	BROWN	WHITE	RED	BLUE	PURPLE
RIGHT TURN & BRAKE	LEFT TURN & BRAKE	TAILLIGHTS	GROUND	AUXILIARY POWER	ELECTRIC BRAKES	BACK-UP LIGHTS

CURT DISCLAIMER: WIRING COLOR SHOWN WORK IN CONJUNCTION WITH CURT MANUFACTURING PRODUCTS.

11419**KIA SOUL****GROSS LOAD CAPACITY WHEN USED AS A WEIGHT CARRYING HITCH: 2000 LBS. TRAILER WEIGHT & 200 LBS. TONGUE WEIGHT.*******DO NOT EXCEED VEHICLE MANUFACTURER'S RECOMMENDED TOWING CAPACITY.*******WARNING: ALL NON-TRAILER LOADS APPLIED TO THIS PRODUCT MUST BE SUPPORTED BY 18050 STABILIZING STRAPS.****Parts List**

ITEM	QTY	PART NUMBER	DESCRIPTION
1	6	M10 - 1.25 x 30	HEX BOLT
2	6	7/16"	CONICAL TOOTHED WASHER

TOOLS REQUIRED

PHILLIPS SCREWDRIVER
FLAT BLADE SCREWDRIVER
10mm AND 17mm SOCKETS
12" EXTENSION
RATCHET
TORQUE WRENCH

**RUBBER ISOLATOR
REMOVAL DIAGRAM**

This technique can be used if an Exhaust Hanger Removal Pliers is not available.

Using a 5/8" open end wrench, slide the wrench up to the rubber isolator, cradling the hanger rod as shown. Next place the flat edge of a pry bar between the wrench and the hanger stop or hanger rod. Then simply rotate the pry bar toward the wrench to remove the rubber isolator.

Note: Using a spray lubricant or soapy water on the hanger rod and the rubber isolator helps removal.

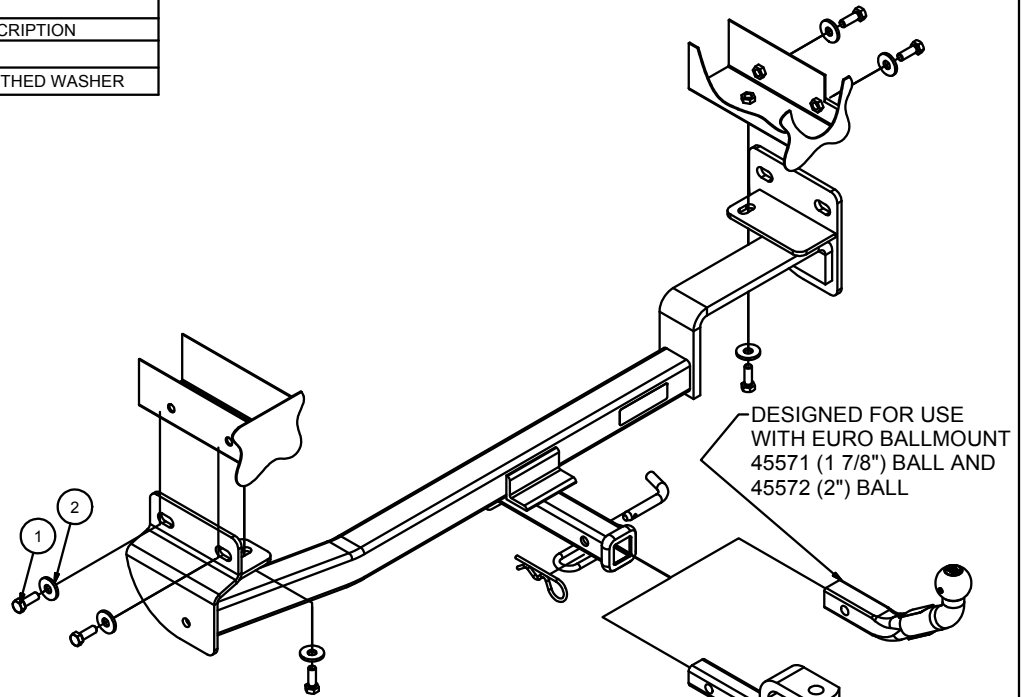
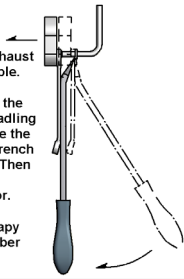
**HITCH WEIGHT:** 28 LBS.**INSTALL TIME**

PROFESSIONAL: 30 MINUTES

NOVICE (DIY): 60 MINUTES

INSTALL NOTES:

- NO DRILLING
- LOWER EXHAUST

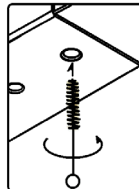
**WELDNUT CLEANING**

To remove debris from weldnuts in frame, spray lubricant or compressed air into hole. For heavy debris, use a small wire brush. (Be careful not to damage threads).

DESIGNED FOR USE WITH BALL MOUNT #45521/D-21

FRONT
REAR**INSTALLATION STEPS**

1. Remove the splash shields and liners in both rear wheel wells by removing the (4) push fasteners and (6) screws securing them. Gently separate the wheel well liner from the fender well to allow for hitch installation.
2. Lower the exhaust by removing the (1) rearmost rubber isolator from the hanger. (See Rubber Isolator Removal Diagram.)
3. Optional - For ease of install - Remove the (3) nuts securing the canister at the driver side frame rail using 10mm socket. Use a small screwdriver on the spring clips to remove canister from frame. Carefully suspend canister during hitch installation.
4. Raise the hitch into position and align the holes in the side plates with the holes in the sides of the frame rails. Secure the hitch with 7/16" conical toothed washers and M10 hex bolts into each weldnut.

Torque all M10 hex bolts to 48 ft-lbs.

5. Raise exhaust back into position and secure to vehicle hanger.

If Step 3 was executed: Raise canister back into position and reattach using factory hardware.

6. Reinstall the splash shields into the wheel wells. Trimming of drivers wheel well may be required around driver side plate.

Installation Complete

PERIODICALLY CHECK THIS RECEIVER HITCH TO ENSURE THAT ALL FASTENERS ARE TIGHT AND THAT ALL STRUCTURAL COMPONENTS ARE SOUND.