



Safety glasses should be worn at all times while installing this product.

YEARS: 2015

MAKE: VOLKSWAGEN

MODEL: JETTA TDI

STYLE: SEDAN





**WARNING: NEVER EXCEED YOUR VEHICLE MANUFACTURER'S RECOMMENDED TOWING CAPACITY**

**WEIGHT CARRYING:**  
 TRAILER WEIGHT: 2,000 LBS.  
 TONGUE WEIGHT: 200 LBS.

**PRO INSTALL TIME: 45 MIN.**  
**NOVICE INSTALL TIME: 90 MIN.**

IF YOU ARE HESITANT TO UNDERTAKE THIS TASK ON YOUR OWN, CONTACT AN AUTHORIZED CURT INSTALLER FOR ADDITIONAL ASSISTANCE.



**INSTALLATION REQUIRES:**

|  |  |   |
|--|--|---|
| <br><b>13mm 1/2"</b><br>SOCKET | <br><b>#25 TORXBIT SOCKET</b> | <br><b>10"</b><br>SOCKET EXTENSION |
| <br>RATCHET                   | <br>TORQUE WRENCH            |   |
|  |  |   |
|  |  |   |

**INSTALLATION TIPS:**

- BEFORE YOU BEGIN INSTALLATION, READ ALL INSTRUCTIONS THOROUGHLY.
- TO EASE INSTALLATION, 2 PEOPLE MAY BE REQUIRED.
- USING PROPER TOOLS WILL GREATLY IMPROVE THE QUALITY OF THE INSTALL AND REDUCE THE TIME REQUIRED.

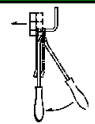
**LEVEL OF DIFFICULTY: MODERATE**

| EASY   | MODERATE                  | CHALLENGING |
|--|---------------------------|-------------|
|   | TEMPORARILY LOWER EXHAUST |             |
|  | NO DRILLING               |             |
|  |                           |             |
|  |                           |             |

**VEHICLE PHOTO:**



REPRESENTATIVE PHOTO

**HITCH ILLUSTRATION:**

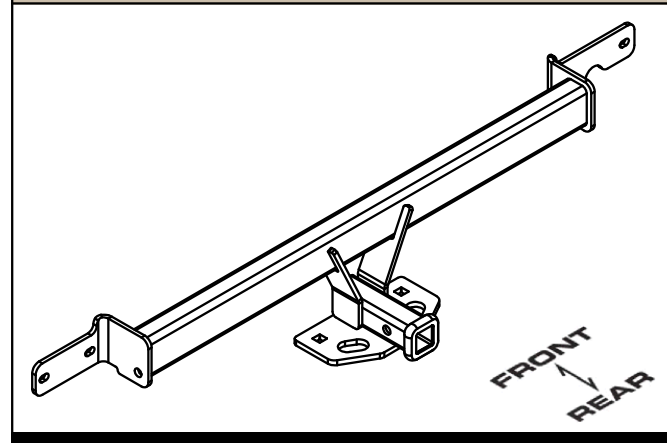

MAKE SURE YOUR HITCH MATCHES

## INSTALLATION WALKTHROUGH:

| Parts List |     |                     |                              |
|------------|-----|---------------------|------------------------------|
| ITEM       | QTY | PART NUMBER         | DESCRIPTION                  |
| 1          | 4   | M8 - 1.25 x 30 HFB  | M8-1.25 x 30 HEX FLANGE BOLT |
| 2          | 4   | 1/2-13 x 1 1/2, GR8 | CARRIAGE BOLT                |
| 3          | 4   | HFN 1213, GR8       | HEX FLANGE NUT               |
| 4          | 2   | 11410-SP            | .250" SPACER                 |
| 5          | 1   | 11410-TB            | .313" TAIL BRACKET           |

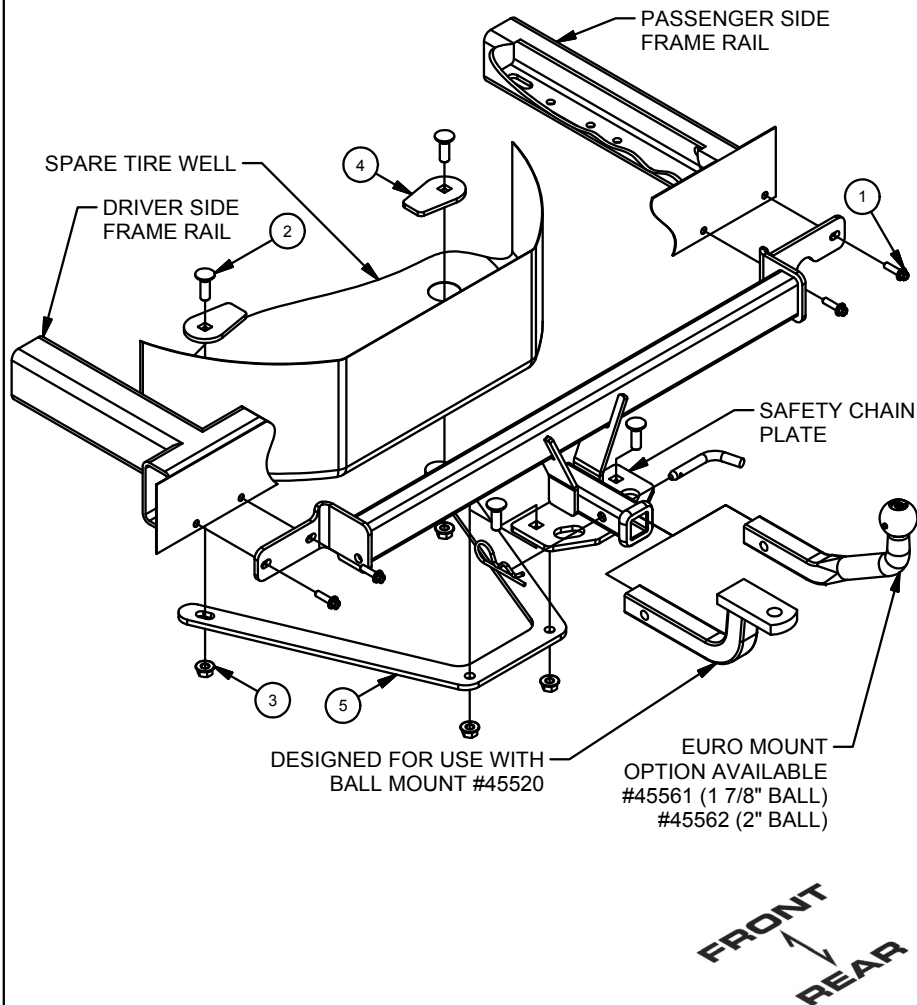

1. Remove (3) torx head bumper cover retention screws. Temporarily lower the exhaust by removing the rubber exhaust isolator. (Save screws for use in Step 4)



2. Remove the (4) lowest M8 bolts from the bumper beam and return to vehicle owner.



## INSTALLATION WALKTHROUGH:

3. Raise hitch into position starting with the drivers side carefully pulling out the bumper cover to allow the hitch to slide into position. Secure the hitch in place using the supplied (4) M8 hex flange bolts as shown below.



4. Place (2) 1/2" carriage bolts into the square holes in the chain loop plate. Reattach exhaust and secure bumper cover using the (2) outer fasteners removed in Step 1. Note: Center attachment is no longer accessible.



5. Remove the contents of the trunk including the spare tire. Remove both plugs from the spare tire well and return to vehicle owner.

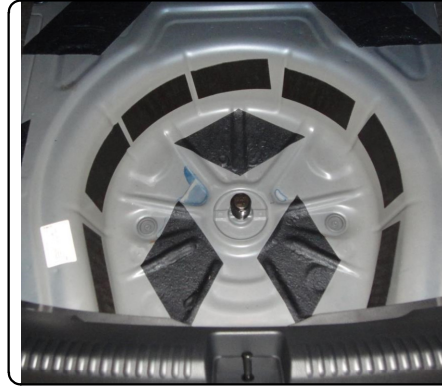

6. Use silicone caulk (or equivalent) to seal the tire well plug hole from exhaust fumes and water by putting a bead around each hole inside the spare tire well. Place a 11410-SP spacer onto each hole and put a bead of caulk around each square hole. Install a 1/2" carriage bolt into each hole.



## INSTALLATION WALKTHROUGH:

7. Raise 11410-TB tail bracket into position over carriage bolts in spare tire well and hitch safety chain plate, secure with (4) 1/2" hex flange nuts.



8. Return spare tire and other items removed in Step 8 to the trunk. Torque 1/2" fasteners to 110 ft-lbs and M8 fasteners to 23 ft-lbs.

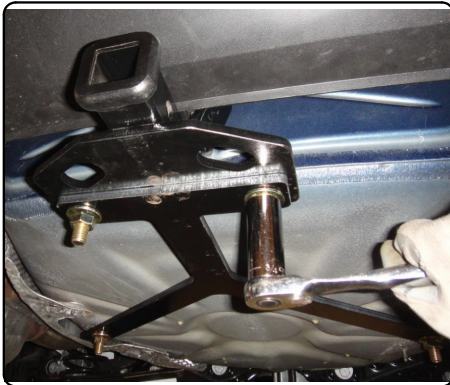

## TOWING SAFETY INFORMATION

### Gross Trailer Weight / GTW

The Gross Trailer Weight is the weight of the trailer & cargo. Measure this by putting the fully loaded trailer on a vehicle scale.

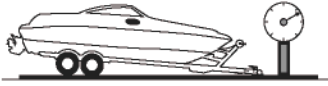

### Tongue Weight / TW

The downward force that is exerted on the hitch ball by the coupler. The tongue weight will vary depending on where the load is positioned in relationship to the trailer axle(s). To measure the tongue weight, use either a commercial scale or a bathroom scale with the coupler at towing height. When using a bathroom scale with heavier tongue weights, use the method shown and multiply the scale reading by 3.

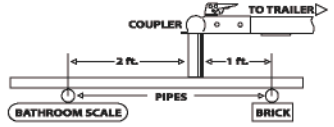

### Weight Carrying / WC

The total weight of both the trailer and the cargo inside. Never exceed the weight capacity of your trailer hitch.

### Weight Distribution / WD

Used to balance the weight of the cargo between the front and rear wheels throughout the trailer, allowing for better steering, braking, and level riding.



### Sway Control

A device used to reduce the lateral movements of the trailer that are caused by the wind. This works in conjunction with a weight distribution hitch. Do not use this on a class 1 or 2 hitch, or with surge brakes.

### How Much Can You Safely Tow?

| TONGUE WEIGHT lbs   | 1000 | 2000 | 3000 | 4000 | 5000 | 6000 | 7000 | 8000 | 10,000 | 12,000 |
|---|------|------|------|------|------|------|------|------|--------|--------|
| Tongue weight should be about 10 to 15 percent of the gross trailer weight. |      |      |      |      |      |      |      |      |        |        |
| CLASS 1   |      |      |      |      |      |      |      |      |        |        |
| CLASS 2   |      |      |      |      |      |      |      |      |        |        |
| CLASS 3   |      |      |      |      |      |      |      |      |        |        |
| CLASS 4   |      |      |      |      |      |      |      |      |        |        |
| CLASS 5   |      |      |      |      |      |      |      |      |        |        |
| <b>Camper</b>   | 11'  | 12'  | 13'  | 14'  | 15'  | 16'  |      |      |        |        |
| lbs   | 1100 | 1200 | 1300 | 1400 | 1500 | 1600 |      |      |        |        |
| <b>Vacation</b>   | 14'  | 16'  | 18'  | 20'  | 22'  | 24'  | 26'  | 28'  | 30'    | 32'    |
| lbs   | 2100 | 2400 | 2700 | 3000 | 3300 | 3600 | 3900 | 4200 | 4500   | 4800   |
| <b>Vacation</b>   | 14'  | 16'  | 18'  | 20'  | 22'  | 24'  | 26'  | 28'  | 30'    | 32'    |
| lbs   | 2800 | 3200 | 3600 | 4000 | 4400 | 4800 | 5200 | 5600 | 6000   | 6400   |
| <b>5th Wheel</b>  |      |      |      |      |      |      |      |      |        |        |

Refer to owner's manual for towing capabilities and limitations.

### Ball Mount

The ball mount is placed inside the opening of the receiver hitch which is mounted to the vehicle. Make sure a hitch pin and clip is properly securing the ball mount to the receiver hitch before you begin towing.

- A: Rise. B: Drop. C: Hole Size. D: Length.

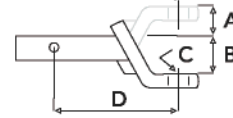

### Trailer Ball

The connection from the hitch to the trailer. There are many factors that determine the correct hitch ball:

- Number one is the hitch ball's gross trailer weight rating.
- The mounting platform must be at least 3/8" thick.
- The hole diameter must not be more than 1/16" larger than the threaded shank.
- Every time you tow, check the nut and lock washer to make sure they are fastened securely.
- A: Ball Dia. B: Shank Dia. C: Shank Length. D: Shank Rise.

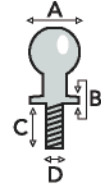

### Coupler

The component that is placed over the trailer ball to connect the vehicle to the trailer. Be sure that the coupler size matches the size of the hitch ball and that the coupler handle is securely fastened. To determine what size hitch ball you need for your application you will need to know the size of coupler that is on the trailer. Be sure your coupler is properly adjusted to the ball you are using.

NOTE: For added security the use of safety devices such as Coupler Safety Pins and Locks is strongly recommended.

### Safety Chains

Safety chains are a requirement and should be crossed under the tongue of the trailer so that the tongue will not drop to the road if it becomes separated from the hitch. Always leave enough slack so you can turn. Never allow the safety chains to drag on the ground and never attach the chains to the bumper.

Trailer Classification: Safety Chain Breaking Force - Minimum

- Class 1: 2,000 lbs. (8.9 kN)
- Class 2: 3,500 lbs. (15.6 kN)
- Class 3: 5,000 lbs. (22.2 kN)

The strength rating of each length of safety chain or its equivalent and its attachments shall be equal to or exceed in minimum breaking force the GVWR (Gross Vehicle Weight Rating) of the trailer.

### Electrical

Trailer lights, Electric Brakes, Break-away systems - Every time you tow, be sure to check that all components are working properly.

Wiring identification by color:

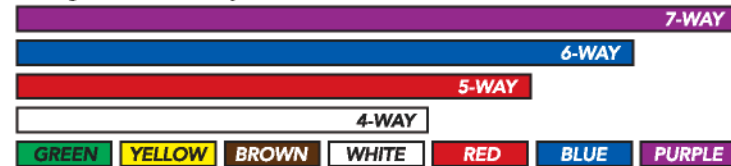

11410

## VOLKSWAGEN JETTA TDI

GROSS LOAD CAPACITY WHEN USED AS A WEIGHT CARRYING HITCH: 2000 LBS. TRAILER WEIGHT &amp; 200 LBS. TONGUE WEIGHT.

**\*\*\*DO NOT EXCEED VEHICLE MANUFACTURER'S RECOMMENDED TOWING CAPACITY.\*\*\***

WARNING: ALL NON-TRAILER LOADS APPLIED TO THIS PRODUCT MUST BE SUPPORTED BY 18050 STABILIZING STRAPS.

**\*\* FAILURE TO PROPERLY SUPPORT NON-TRAILER LOADS WILL VOID PRODUCT WARRANTY\*\***

| Parts List |     |                     |                              |
|------------|-----|---------------------|------------------------------|
| ITEM       | QTY | PART NUMBER         | DESCRIPTION                  |
| 1          | 4   | M8 - 1.25 x 30 HFB  | M8-1.25 x 30 HEX FLANGE BOLT |
| 2          | 4   | 1/2-13 x 1 1/2, GR8 | CARRIAGE BOLT                |
| 3          | 4   | HFN 1213, GR8       | HEX FLANGE NUT               |
| 4          | 2   | 11410-SP            | .250" SPACER                 |
| 5          | 1   | 11410-TB            | .313" TAIL BRACKET           |

| TOOLS REQUIRED  |
|-----------------|
| #25 TORX DRIVER |
| 13mm SOCKET     |
| 3/4" SOCKET     |
| 10" EXTENSION   |
| RATCHET         |
| TORQUE WRENCH   |

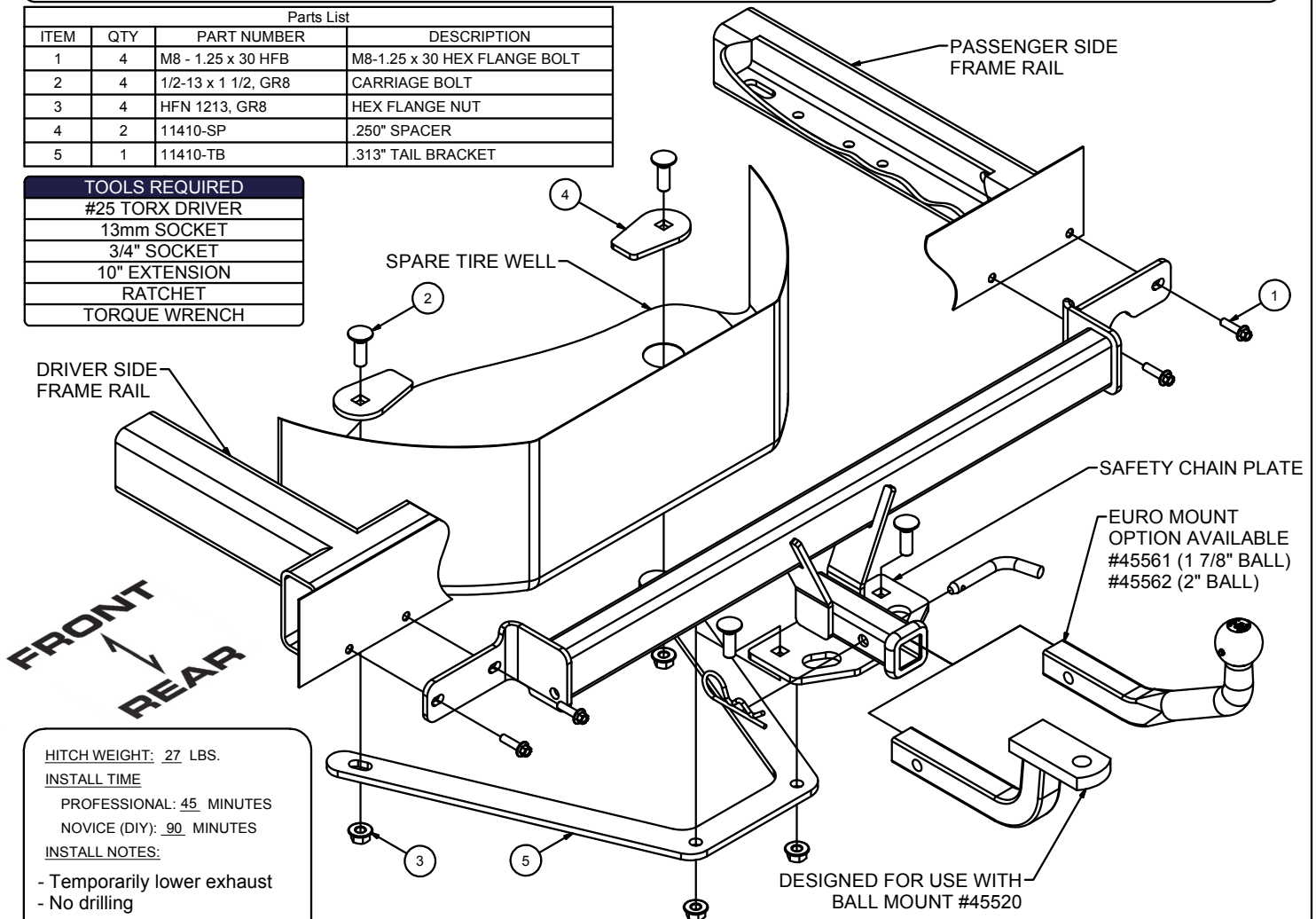

HITCH WEIGHT: 27 LBS.

## INSTALL TIME

PROFESSIONAL: 45 MINUTES

NOVICE (DIY): 90 MINUTES

## INSTALL NOTES:

- Temporarily lower exhaust
- No drilling

DESIGNED FOR USE WITH BALL MOUNT #45520

**INSTALLATION STEPS**

1. Remove (3) torx head bumper cover retention screws. Temporarily lower the exhaust by removing the rubber exhaust isolator. (Save screws for use in Step 4)
2. Remove the (4) lowest M8 bolts from the bumper beam and return to vehicle owner.
3. Raise hitch into position starting with the drivers side carefully pulling out the bumper cover to allow the hitch to slide into position. Secure the hitch in place using the supplied (4) M8 hex flange bolts as shown above.
4. Place (2) 1/2" carriage bolts into the square holes in the chain loop plate. Reattach exhaust and secure bumper cover using the (2) outer fasteners removed in Step 1. Note: Center attachment is no longer accessible.
5. Remove the contents of the trunk including the spare tire. Remove both plugs from the spare tire well and return to vehicle owner.
6. Use silicone caulk (or equivalent) to seal the tire well plug hole from exhaust fumes and water by putting a bead around each hole inside the spare tire well. Place a 11410-SP spacer onto each hole and put a bead of caulk around each square hole. Install a 1/2" carriage bolt into each hole.
7. Raise 11410-TB tail bracket into position over carriage bolts in spare tire well and hitch safety chain plate, secure with (4) 1/2" hex flange nuts.
8. Return spare tire and other items removed in Step 8 to the trunk. Torque 1/2" fasteners to 110 ft-lbs and M8 fasteners to 23 ft-lbs.

**PERIODICALLY CHECK THIS RECEIVER HITCH TO ENSURE THAT ALL FASTENERS ARE TIGHT AND THAT ALL STRUCTURAL COMPONENTS ARE SOUND.**

Learn more about trailer hitches and towing we have.