



Safety glasses should be worn at all times while installing this product.

YEARS: 2013-PRESENT

MAKE: LEXUS

MODEL: GS350

STYLE: SEDAN

WARNING: NEVER EXCEED YOUR VEHICLE MANUFACTURER'S RECOMMENDED TOWING CAPACITY

WEIGHT CARRYING:
 TRAILER WEIGHT: 2000 LBS.
 TONGUE WEIGHT: 200 LBS.

PRO INSTALL TIME: 90 MIN.
NOVICE INSTALL TIME: 180 MIN.

IF YOU ARE HESITANT TO UNDERTAKE THIS TASK ON YOUR OWN, CONTACT AN AUTHORIZED CURT INSTALLER FOR ADDITIONAL ASSISTANCE.

INSTALLATION REQUIRES:

	10mm 12mm	
FLAT & PHILLIPS SCREW DRIVERS	SOCKET	RATCHET
TORQUE WRENCH	ROTARY TOOL	MARKER
6" SOCKET EXTENSION	SAFETY GLASSES	

INSTALLATION TIPS:

- BEFORE YOU BEGIN INSTALLATION, READ ALL INSTRUCTIONS THOROUGHLY.
- TO EASE INSTALLATION, 2 PEOPLE MAY BE REQUIRED.
- USING PROPER TOOLS WILL GREATLY IMPROVE THE QUALITY OF THE INSTALL AND REDUCE THE TIME REQUIRED.

LEVEL OF DIFFICULTY: CHALLENGING

EASY	MODERATE	CHALLENGING
	TRIM UNDERBODY PANEL	
	REMOVE BUMPER	
	NO DRILLING REQUIRED	

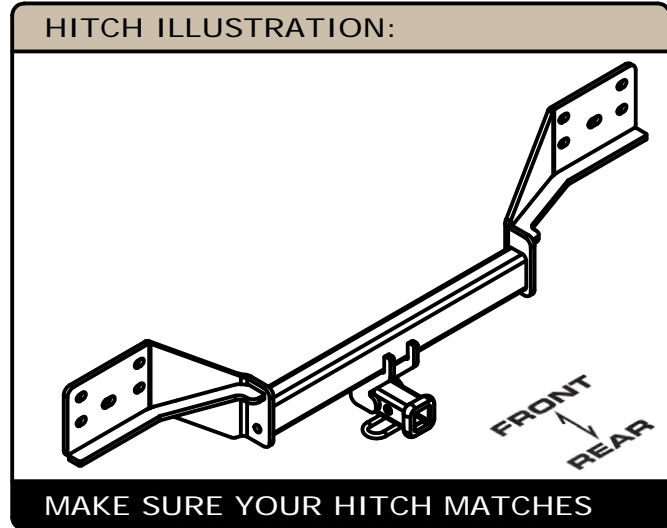

INSTALLATION WALKTHROUGH:

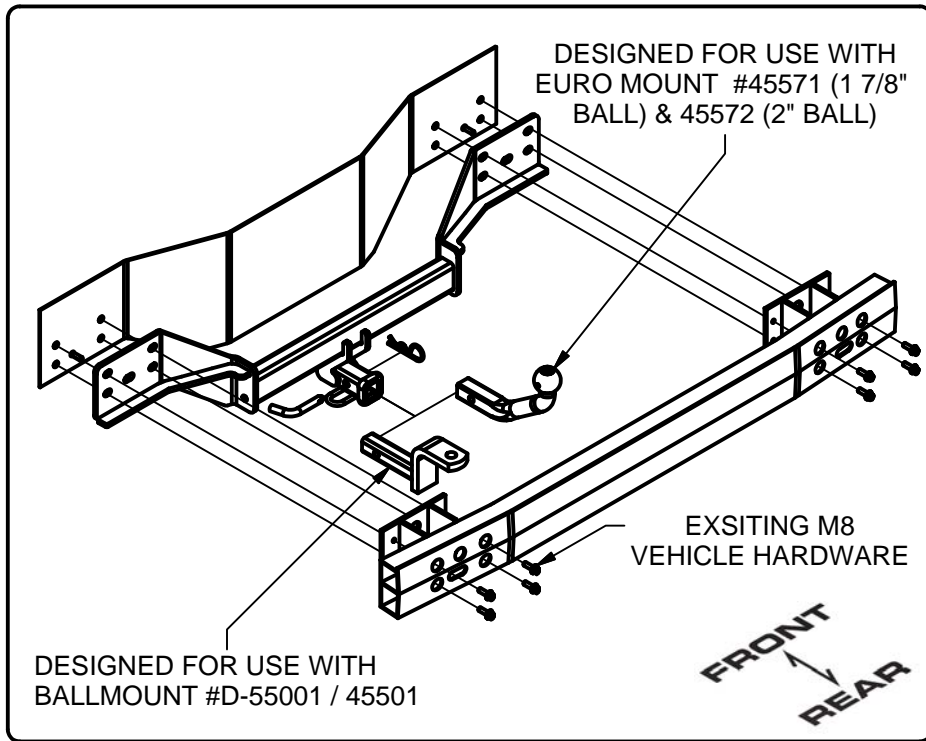

1. Begin bumper cover removal process by removing (1) screw, (1) push fastener from behind rear tire, and (1) push fastener from the wheel well.



2. Remove (1) screw hidden behind the wheel well at the top of the fascia. Remove the plastic clip by prying it out with a flat head screw driver.

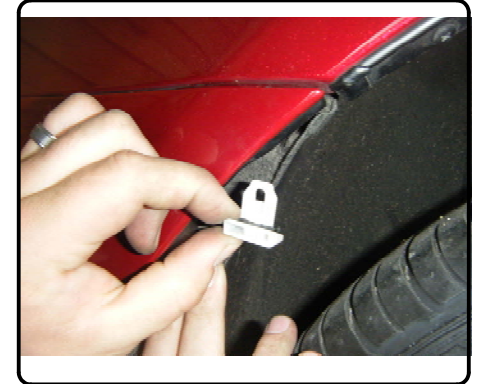

3. Remove small plastic panel between tail light and trunk opening. Remove exposed screw.

Repeat STEPS 1-3 on the other side of the vehicle.

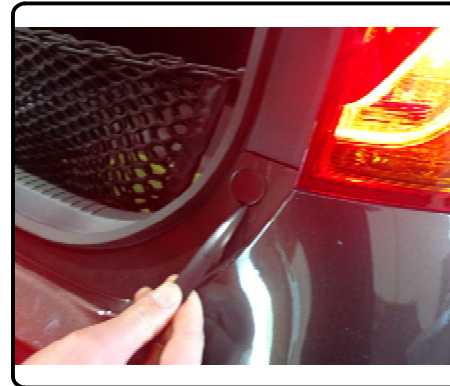

INSTALLATION WALKTHROUGH:

4. Remove (8) push fasteners from around the rear of the fascia, with a flat head screw driver.



6. Remove foam and set aside for reinstall later.



5. Carefully remove bumper cover. Pop sides off first and then pull straight back.

NOTE: Disconnect electrical connector under driver side tail light.



7. Remove bumper beam by removing (8) M8 bolts.

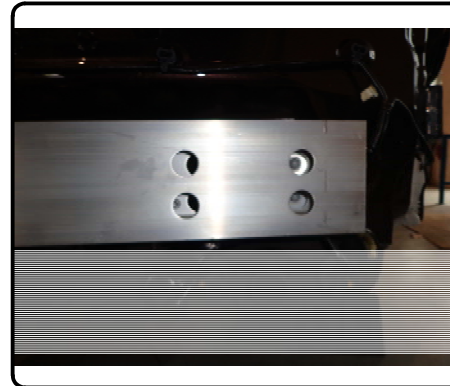

INSTALLATION WALKTHROUGH:

8. With a rotary tool remove alignment stud (each side as shown) and trim the center of the underbody panel (as shown).

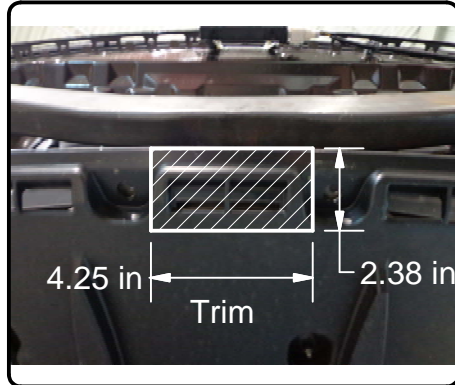
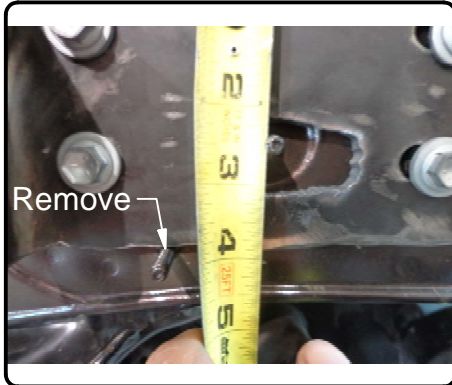

9. Raise hitch and bumper beam into position and secure to the vehicle with the M8 bolts removed in STEP 7. Torque all M8 hardware to 23 ft-lbs.



10. Reinstall bumper cover by reassembling components removed in STEPS 1-6 in reverse order.



11. Install is now complete.

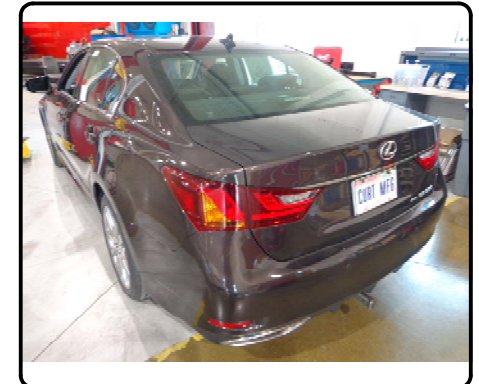

11366

LEXUS GS 350

GROSS LOAD CAPACITY WHEN USED AS A WEIGHT CARRYING HITCH: 2000 LBS. TRAILER WEIGHT & 200 LBS. TONGUE WEIGHT.

DO NOT EXCEED VEHICLE MANUFACTURER'S RECOMMENDED TOWING CAPACITY.

WARNING: ALL NON-TRAILER LOADS APPLIED TO THIS PRODUCT MUST BE SUPPORTED BY 18050 STABILIZING STRAPS.

** FAILURE TO PROPERLY SUPPORT NON-TRAILER LOADS WILL VOID PRODUCT WARRANTY**

TOOLS REQUIRED

FLAT & PHILLIPS SCREW DRIVER
10mm & 12 mm SOCKETS
RATCHET & 6" EXTENSION
TORQUE WRENCH
ROTARY TOOL
MARKER

TRIM DIAGRAM

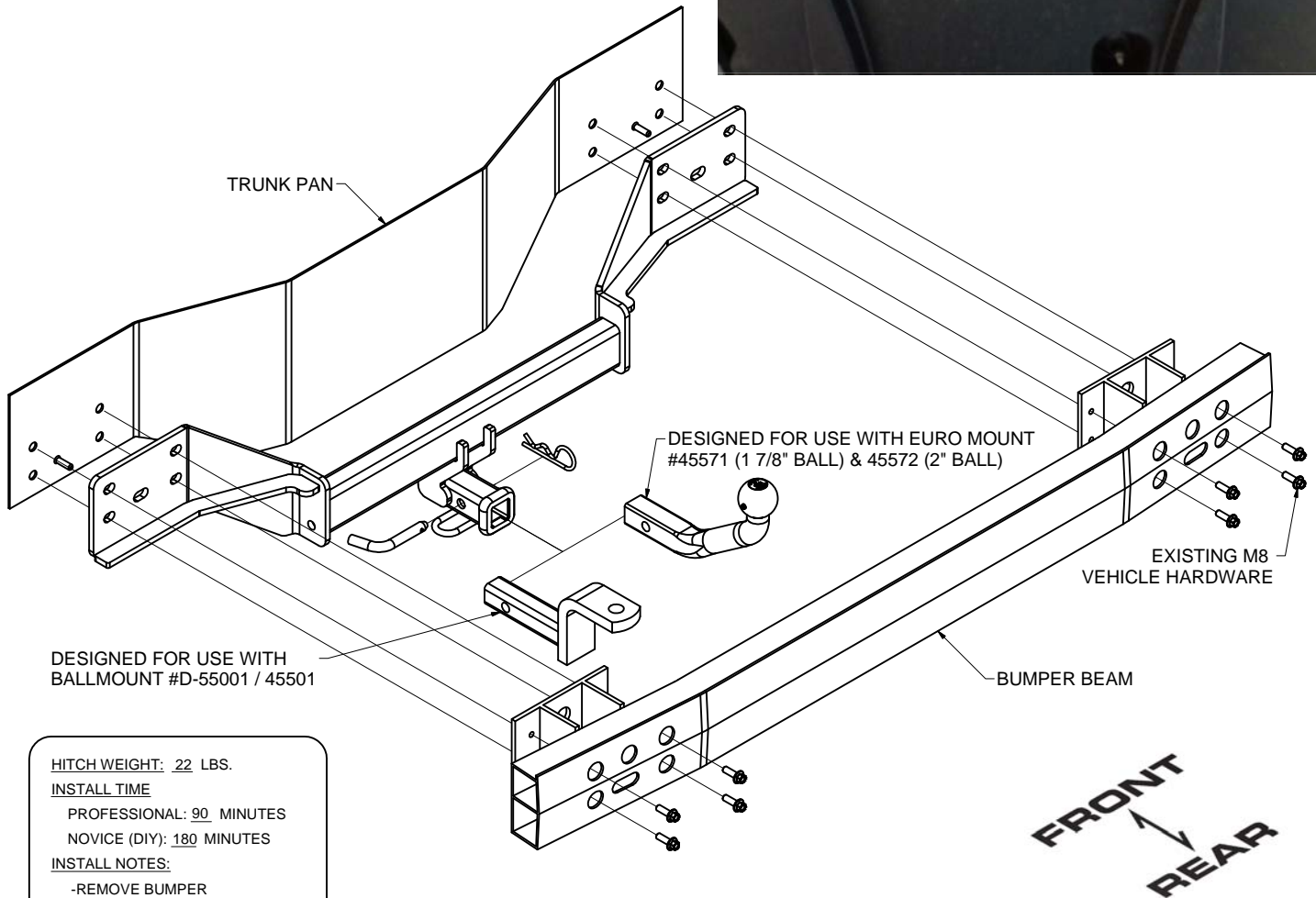
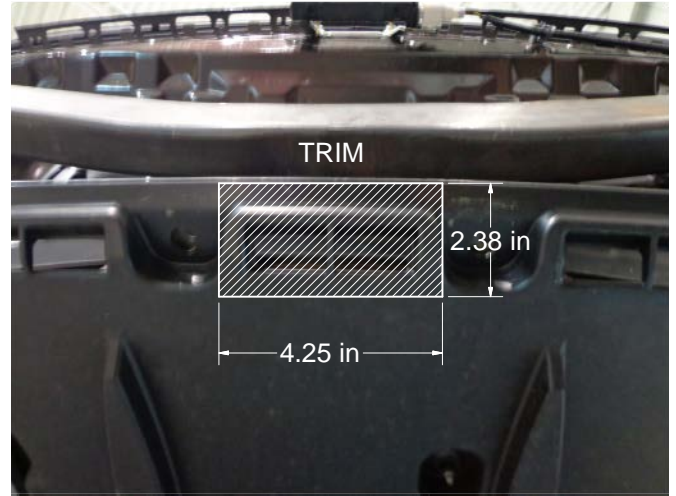

HITCH WEIGHT: 22 LBS.

INSTALL TIME

PROFESSIONAL: 90 MINUTES

NOVICE (DIY): 180 MINUTES

INSTALL NOTES:

- REMOVE BUMPER
- TRIM UNDERBODY PANEL
- NO DRILLING REQUIRED

PERIODICALLY CHECK THIS RECEIVER HITCH TO ENSURE THAT ALL FASTENERS ARE TIGHT AND THAT ALL STRUCTURAL COMPONENTS ARE SOUND.

INSTALLATION STEPS

1. Begin bumper cover removal process by removing (1) screw, (1) push fastener from behind rear tire, and (1) push fastener from the wheel well.
2. Remove (1) screw hidden behind the wheel well at the top of the fascia. Remove the plastic clip by prying it out with a flat head screw driver.
3. Remove small plastic panel between tail light and trunk opening. Remove the exposed screw. Repeat STEPS 1 -3 on the other side of the vehicle.
4. Remove (8) push fasteners from the rear of the fascia, with a flat head screw driver.
5. Carefully remove bumper cover. Pop sides off first and then pull straight back.
Note: Disconnect electrical connector under driver side tail light.
6. Remove foam and set aside for reinstall later.
7. Remove bumper beam by removing (8) M8 bolts.
8. With a rotary tool remove the lower alignment stud from bumper beam location.
9. Trim underbody panel and reinstall. See TRIM DIAGRAM.
10. Raise hitch and bumper beam into position and secure to the vehicle with the M8 bolts removed in STEP 7. Torque all M8 hardware to 23 ft-lbs.
11. Reinstall bumper cover by reassembling components removed in STEPS 1-6 in reverse order.

PERIODICALLY CHECK THIS RECEIVER HITCH TO ENSURE THAT ALL FASTENERS ARE TIGHT AND THAT ALL STRUCTURAL COMPONENTS ARE SOUND.