

15704

03-CURRENT DODGE RAM 2500/3500 WITHOUT OEM RECEIVER
 03-08 DODGE RAM 1500 BUILT AFTER NOV. 2002 WITHOUT OEM RECEIVER

GROSS LOAD CAPACITY WHEN USED AS A WEIGHT CARRYING HITCH: 18,000 LBS. TRAILER WEIGHT & 2,700 LBS. TONGUE WEIGHT.
 GROSS LOAD CAPACITY WHEN USED AS A WEIGHT DISTRIBUTION HITCH: 18,000 LBS. TRAILER WEIGHT & 2,700 LBS. TONGUE WEIGHT
***** DO NOT EXCEED VEHICLE MANUFACTURER'S RECOMMENDED TOWING CAPACITY.*****

Parts List			
ITEM	QTY	PART NUMBER	DESCRIPTION
1	2	9/16-12 x 2	HEX BOLT
2	2	9_16 FISHWIRE	9/16" FISHWIRE
3	2	9_16 WASHER USS FLAT	FLAT WASHER
4	6	9_16-12 FLANGE NUT	HEX FLANGE NUT
5	4	9_16-12 x 1 3/4	CARRIAGE BOLT
6	2	CM-SP68	.250 x 2.13 x 2.13" 9/16" SQUARE HOLE SPACER
7	2	CM-SP74	.250 x 1.50 x 3.00" 9/16" SQUARE HOLE SPACER
8	6	CM-SP8	.188 x 1.25 x 1.50" ROUND HOLE SPACER

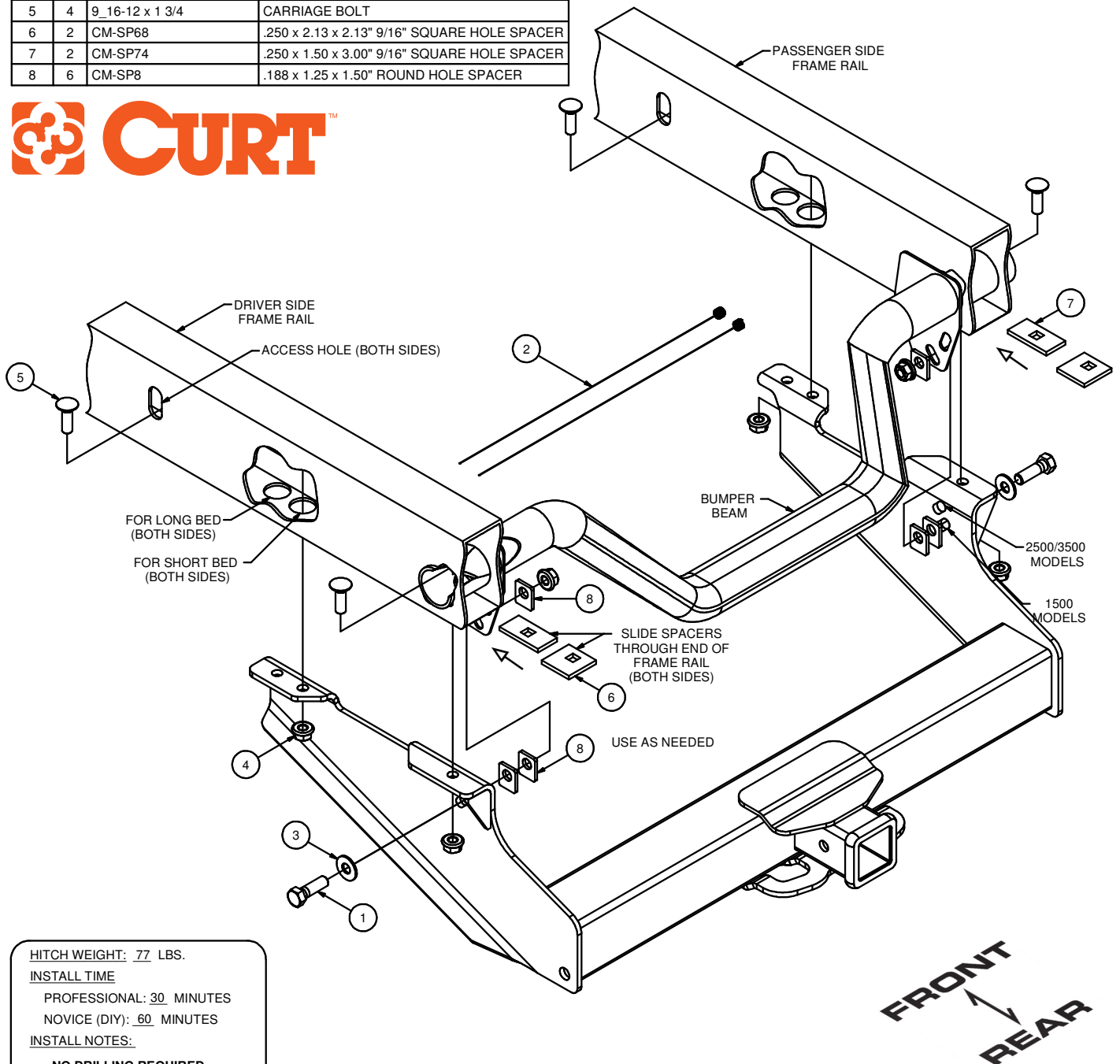

HITCH WEIGHT: 77 LBS.

INSTALL TIME

PROFESSIONAL: 30 MINUTES

NOVICE (DIY): 60 MINUTES

INSTALL NOTES:

- NO DRILLING REQUIRED
- FISHWIRE HARDWARE

PERIODICALLY CHECK THIS RECEIVER HITCH TO ENSURE THAT ALL FASTENERS ARE TIGHT AND THAT ALL STRUCTURAL COMPONENTS ARE SOUND.

15704

03-CURRENT DODGE RAM 2500/3500 WITHOUT OEM RECEIVER
03-08 DODGE RAM 1500 BUILT AFTER NOV. 2002 WITHOUT OEM RECEIVER

GROSS LOAD CAPACITY WHEN USED AS A WEIGHT CARRYING HITCH: 18,000 LBS. TRAILER WEIGHT & 2,700 LBS. TONGUE WEIGHT.
GROSS LOAD CAPACITY WHEN USED AS A WEIGHT DISTRIBUTION HITCH: 18,000 LBS. TRAILER WEIGHT & 2,700 LBS. TONGUE WEIGHT

*** DO NOT EXCEED VEHICLE MANUFACTURER'S RECOMMENDED TOWING CAPACITY.***

FISHWIRE TECHNIQUE

INSERT COILED END OF FISHWIRE TOOL THROUGH HITCH MOUNTING HOLE IN VEHICLE FRAME RAIL AND OUT THE ACCESS HOLE. PASS COILED END OF FISHWIRE THROUGH SPACER AND THREAD BOLT INTO COIL. KINK WIRE TO KEEP SPACER SEPERATE FROM BOLT AS SHOWN. PULL FISHWIRE, SPACER, AND BOLT THROUGH FRAME AND OUT MOUNTING HOLE. USE FISHWIRE TO GUIDE HITCH DURING MOUNTING AND PREVENT LOSS OF BOLT / SPACER INSIDE FRAME RAIL.

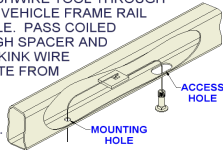

***NOTE: SOME VEHICLES MAY FISHWIRE THROUGH END OF FRAME**

TOOLS REQUIRED

SOCKET WRENCH

TORQUE WRENCH

8 in. SOCKET EXTENSION

13/16" & 7/8" SOCKET

INSTALLATION STEPS

1. Raise hitch into position by aligning holes in hitch side plates with holes in frame rails. **Note:** Hole alignment will depend on vehicle bed length. Long bed vehicles will use front most hole and short bed vehicles will use the middle hole on hitch side plates. **Note:** If equipped with factory hitch, you may need to loosen the hitch/bumper beam and push it towards the rear of vehicle to create additional space for the CURT hitch.
2. Slide CM-SP74 spacers through ends of frame rails and align holes in spacers with front mounting holes. **Note:** Hole alignment will depend on vehicle bed length. Long bed vehicles will use front most hole and short bed vehicles will use the middle hole on hitch side plates.
3. Slide CM-SP68 spacers through ends of frame rails and align holes in spacers with rear mounting holes.
4. Fishwire 9/16" carriage bolts through access holes in side of frame rails and through CM-SP74 spacers from Step 2, as shown. (See FISHWIRE TECHNIQUE diagram.)
5. Fishwire 9/16" carriage bolts through bumper beam and through CM-SP68 spacers from Step 3, as shown. (See FISHWIRE TECHNIQUE diagram.)
6. Secure hitch with 9/16" hex flange nuts onto carriage bolts.
7. Align slots in hitch side plates with slots in vehicle tow loops. Then torque previously installed carriage bolts to 150 lb-ft. (Note: 1500 models will use the bottom slot and 2500/3500 models will use the top slot in hitch side plate.)
8. Install 9/16" hex bolts and flat washers through hitch side plates and tow loops, as shown.
9. Install enough CM-SP8 spacers between tow loops and hitch side plates to prevent the tow loops from pulling into hitch when the hex bolts are tightened.
10. Secure hex bolts with CM-SP8 spacers and 9/16" hex flange nuts, as shown.
11. Torque remaining 9/16" hardware to 150 lb-ft.

PERIODICALLY CHECK THIS RECEIVER HITCH TO ENSURE THAT ALL FASTENERS ARE TIGHT AND THAT ALL STRUCTURAL COMPONENTS ARE SOUND.