

14211

## CHEVROLET / GMC HD TRUCKS

GROSS LOAD CAPACITY WHEN USED AS A WEIGHT CARRYING HITCH: 10,000 LBS. TRAILER WEIGHT & 1,000 LBS. TONGUE WEIGHT.  
 GROSS LOAD CAPACITY WHEN USED AS A WEIGHT DISTRIBUTION HITCH: 12,000 LBS. TRAILER WEIGHT & 1,200 LBS. TONGUE WEIGHT.

\*\*\*DO NOT EXCEED VEHICLE MANUFACTURER'S RECOMMENDED TOWING CAPACITY.\*\*\*

Parts List				
ITEM	QTY	PART NUMBER	DESCRIPTION	
1	4	HFN 1213	HEX FLANGE NUT	
2	4	9/16	LOCK WASHER	
3	4	1/2-13 x 1 3/4	HEX BOLT	
4	2	CM-SP22	.250 x 1.50 x 1.50" ROUND HOLE SPACER	
5	4	CM-SP16	.250 x 1.50 x 2.00" ROUND HOLE SPACER	
6	4	M14-2 x 40mm LG.	HEX BOLT	
7	2	9_16 WASHER	FLAT WASHER	



TOOLS REQUIRED	
RATCHET	
21mm SOCKET	
10" EXTENSION	
21mm BOXED END WRENCH	
TORQUE WRENCH	
DRILL W/ 17/32" DRILL BIT	

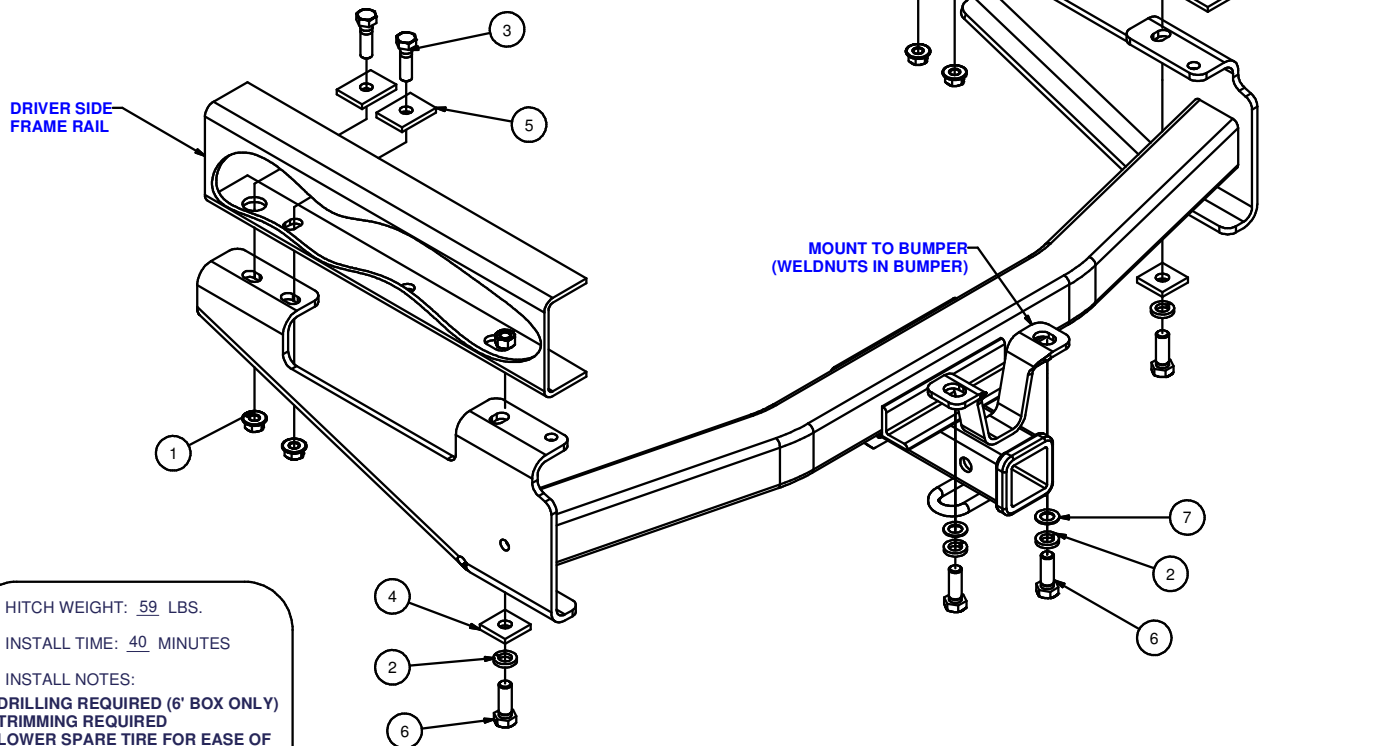
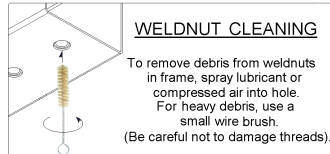

HITCH WEIGHT: 59 LBS.

INSTALL TIME: 40 MINUTES

INSTALL NOTES:

- DRILLING REQUIRED (6' BOX ONLY)
- TRIMMING REQUIRED
- LOWER SPARE TIRE FOR EASE OF INSTALLATION

## INSTALLATION STEPS

- 1) Remove existing M14 fasteners from end of each frame rail if present and return to customer.
- 2) Trim bumper fascia for access to weldnuts in bumper and clearance for bumper mount.
- 3) Lift receiver into position, locating slots in hitch over weldnuts in vehicle frame.
- 4) Install M14 fasteners through hitch into weldnuts in vehicle frame and bumper.
- 5) On 6' short box, use hitch as a template to drill for center attachment on both sides as shown above.
- 6) Torque all M14 fasteners to 126 lb-ft, and all 1/2" fasteners to 110 lb-ft.

**PERIODICALLY CHECK THIS RECEIVER HITCH TO ENSURE THAT ALL FASTENERS ARE TIGHT AND THAT ALL STRUCTURAL COMPONENTS ARE SOUND.**