

13535

2002-2006 HONDA CRV

Will not fit Hybrid

GROSS LOAD CAPACITY WHEN USED AS A WEIGHT CARRYING HITCH: 3500 LBS. TRAILER WEIGHT & 350 LBS. TONGUE WEIGHT.

DO NOT EXCEED VEHICLE MANUFACTURER'S RECOMMENDED TOWING CAPACITY.

WARNING: ALL NON-TRAILER LOADS APPLIED TO THIS PRODUCT MUST BE SUPPORTED BY AUXILIARY STABILIZING STRAPS.

** FAILURE TO PROPERLY SUPPORT NON-TRAILER LOADS WILL VOID PRODUCT WARRANTY**

Parts List			
ITEM	QTY	PART NUMBER	DESCRIPTION
1	2	CM-438-FW	7/16" FISHWIRE TOOL
2	2	HFN3816	HEX FLANGE NUT
3	4	7/16-14 x 1 1/4	CARRIAGE BOLT
4	4	CM-SP2	.250 x .88 x 2.25" SQUARE HOLE SPACER
5	4	7/16-14	LARGE HEX FLANGE NUT
6	1	CM-3805-UBR	3/8-16 x 1.938 x .875" U-BOLT

**RUBBER ISOLATOR
REMOVAL DIAGRAM**

This technique can be used if and Exhaust Hanger Removal Pliers is not available.

Using a 5/8" open end wrench, slide the wrench up to the rubber isolator, cradling the hanger rod as shown. Next place the flat edge of a pry bar between the wrench and the hanger stop or hanger rod. Then simply rotate the pry bar toward the wrench to remove the rubber isolator.

Note: Using a spray lubricant or soapy water on the hanger rod and the rubber isolator helps removal.

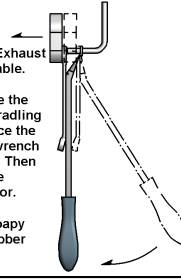
**FISHWIRE TECHNIQUE**

INSERT COILED END OF FISHWIRE TOOL THROUGH HITCH MOUNTING HOLE IN VEHICLE FRAME RAIL AND OUT THE ACCESS HOLE. PASS COILED END OF FISHWIRE THROUGH SPACER AND THREAD BOLT INTO COIL. KINK WIRE TO KEEP SPACER SEPERATE FROM BOLT AS SHOWN. PULL FISHWIRE, SPACER, AND BOLT THROUGH FRAME AND OUT MOUNTING HOLE. USE FISHWIRE TO GUIDE HITCH DURING MOUNTING AND PREVENT LOSS OF BOLT / SPACER INSIDE FRAME RAIL.

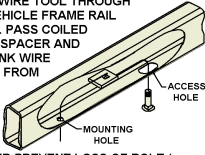

NOTE: SOME VEHICLES MAY FISHWIRE THROUGH END OF FRAME

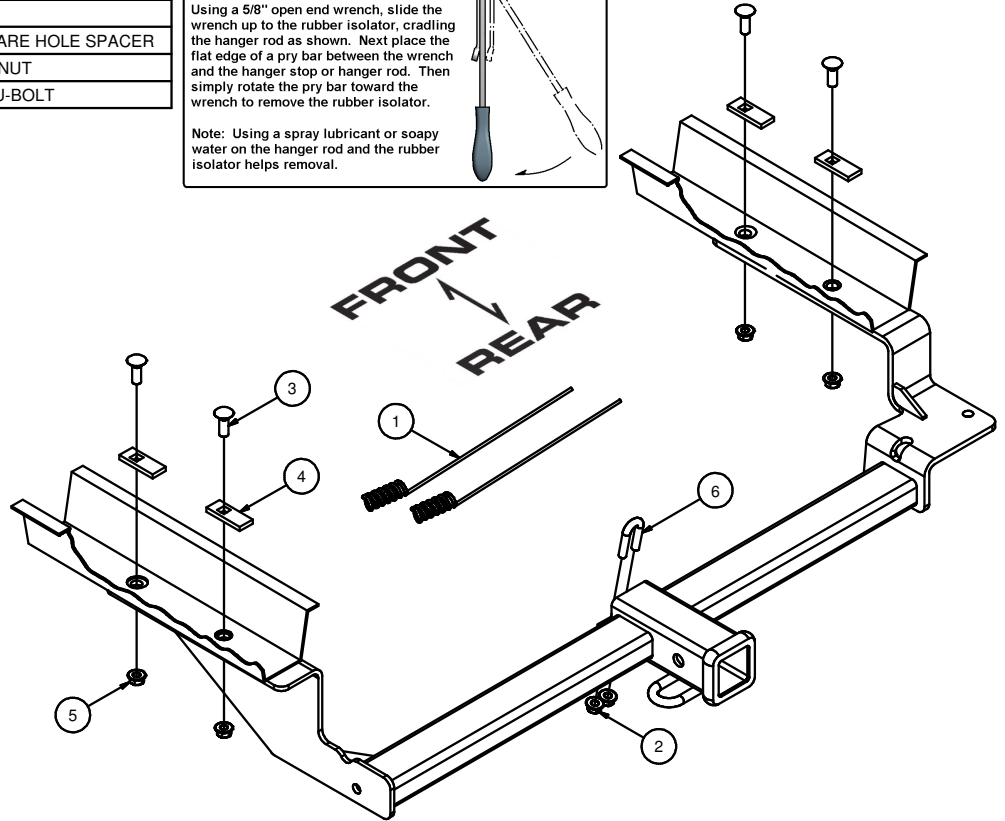

HITCH WEIGHT: 32 LBS.

INSTALL TIME

PROFESSIONAL: 30 MINUTES

NOVICE (DIY): 65 MINUTES

INSTALL NOTES:

- NO DRILLING REQUIRED
- FISHWIRING REQUIRED
- TEMPORARILY LOWER EXHAUST

INSTALLATION STEPS

1. Lower the exhaust by removing the two rear exhaust hangers and one in front of the axle.
2. After the exhaust has been lowered, fishwire a 7/16" carriage bolt and spacer through the large frame hole and out the small front hole in the frame.
3. Remove the fishwire from the front bolt and fishwire a carriage bolt and spacer into the rear frame hole. Repeat the process for the drivers side frame rail.
4. Place the U-bolt over the tow hook in the middle of the vehicle.
5. After all hardware has been properly installed raise the hitch into position and secure with U-bolt and flange nuts first, then attach the remaining 7/16" hardware.
6. Torque all 7/16" hardware to 70 ft-lbs and all 3/8" hardware to 45 ft-lbs.
7. Reattach the three exhaust hangers removed in Step 1.

NOTE: Modify exhaust hangers if muffler interferes with hitch.

PERIODICALLY CHECK THIS RECEIVER HITCH TO ENSURE THAT ALL FASTENERS ARE TIGHT AND THAT ALL STRUCTURAL COMPONENTS ARE SOUND.