

12339**TOYOTA CAMRY (97-06) / SOLARA (99-03) / AVALON (95-04)
LEXUS ES300 (97-01) / ES330 (02-06)****GROSS LOAD CAPACITY WHEN USED AS A WEIGHT CARRYING HITCH: 3500 LBS. TRAILER WEIGHT & 350 LBS. TONGUE WEIGHT.*******DO NOT EXCEED VEHICLE MANUFACTURER'S RECOMMENDED TOWING CAPACITY.*******WARNING: ALL NON-TRAILER LOADS APPLIED TO THIS PRODUCT MUST BE SUPPORTED BY AUXILIARY STABILIZING STRAPS.****** FAILURE TO PROPERLY SUPPORT NON-TRAILER LOADS WILL VOID PRODUCT WARRANTY****

Parts List			
ITEM	QTY	PART NUMBER	DESCRIPTION
1	6	M10 - 1.25 x 30	HEX BOLT
2	2	HFN3816	HEX FLANGE NUT
3	1	CM-3809-UBS	3/8-16 x 1.000 x 2.50 SQ U-BOLT
4	6	3/8"	CONICAL TOOTHED WASHER

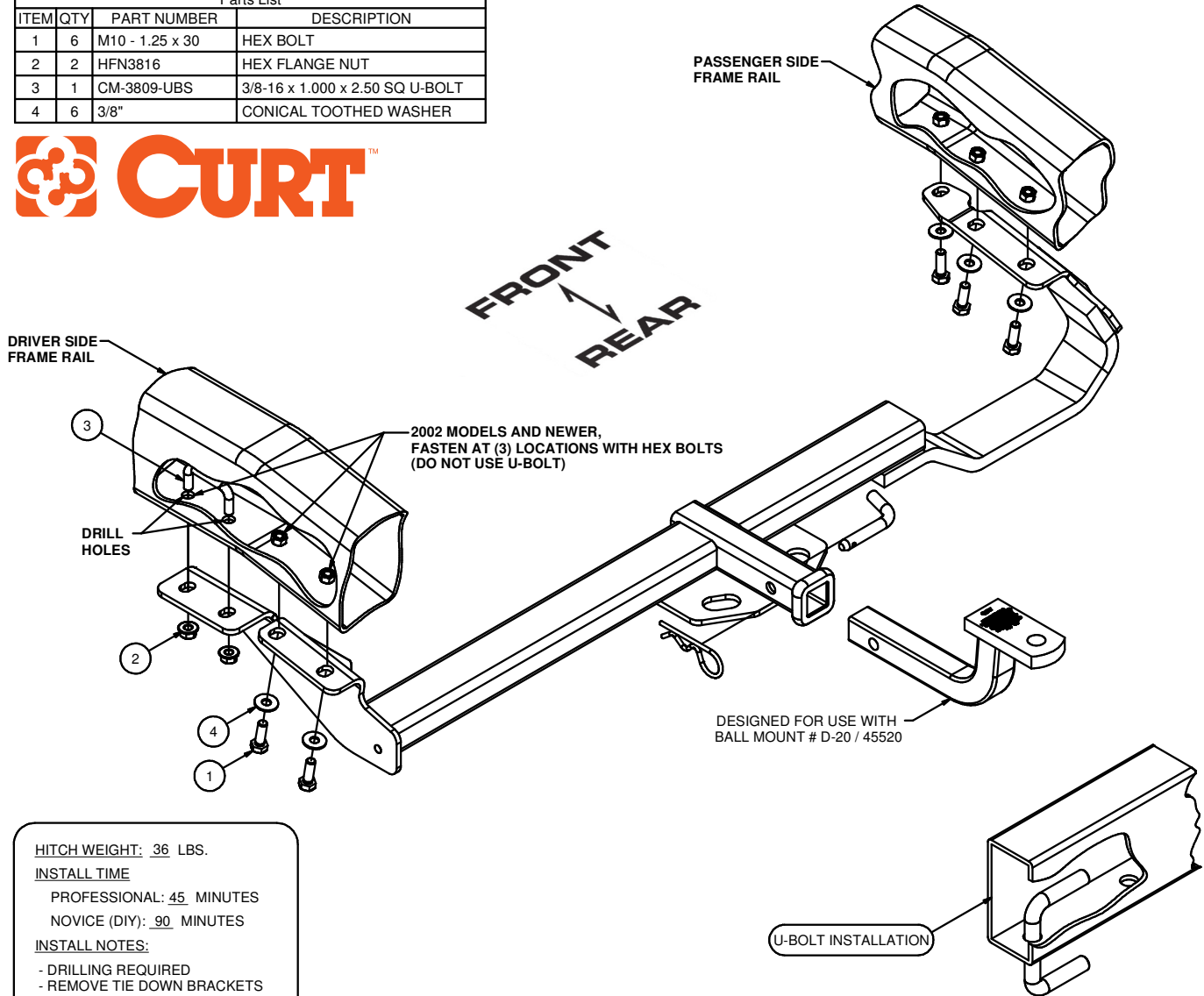

HITCH WEIGHT: .36 LBS.

INSTALL TIME

PROFESSIONAL: .45 MINUTES

NOVICE (DIY): .90 MINUTES

INSTALL NOTES:

- DRILLING REQUIRED
- REMOVE TIE DOWN BRACKETS
- REMOVE 1 HEAT SHIELD BOLT

INSTALLATION STEPS

- 1) Remove tie down brackets from both sides. (Return to customer) On passenger side remove rearmost heat shield bolt. (discard)
- 2) Raise hitch into position, loosely install 3/8" fasteners into existing weldnuts as shown.
- 3) Using hitch as a template, drill 2 holes for 3/8" U-bolt. Install U-bolt and secure with flange nuts as shown. (Note: Camry '02-up and solara 02-'03' use weldnut on driver side instead of U-bolt)
- 4) Torque all 3/8" fasteners to 45 ft-lbs and all M10 fasteners to 48 ft-lbs.

PERIODICALLY CHECK THIS RECEIVER HITCH TO ENSURE THAT ALL FASTENERS ARE TIGHT AND THAT ALL STRUCTURAL COMPONENTS ARE SOUND.