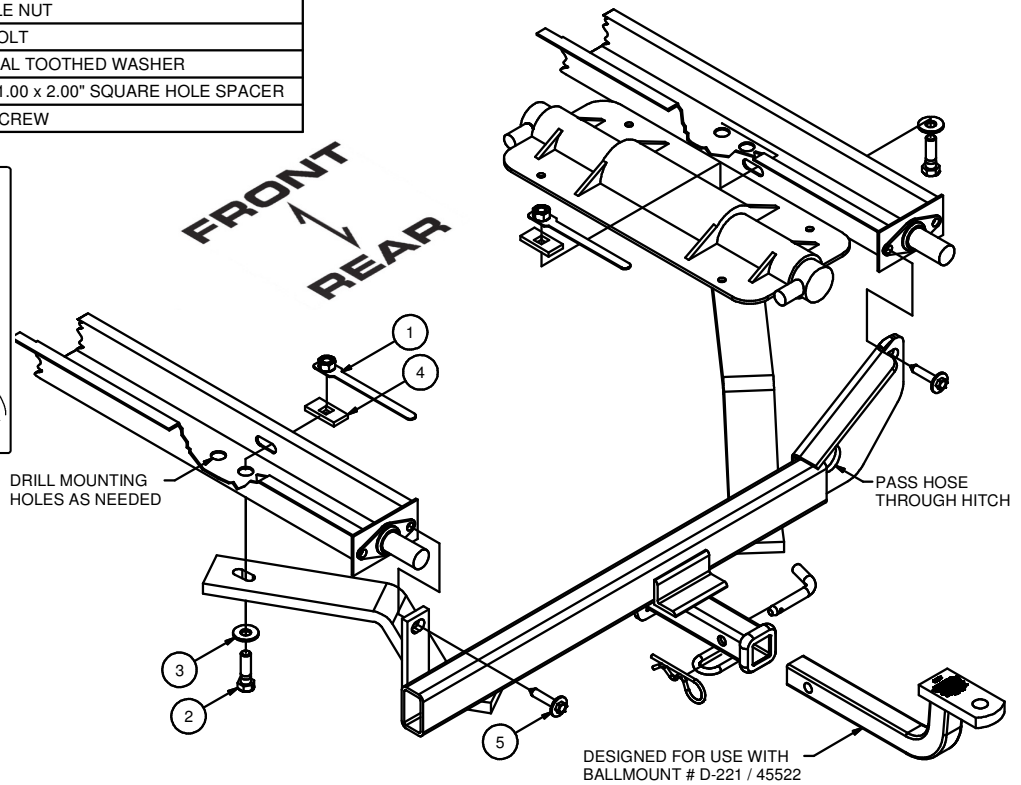
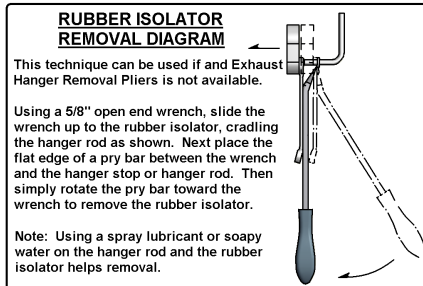

12232**86-07 FORD TAURUS & 86-07 MERCURY SABLE & 88-94 LINCOLN CONTINENTAL****GROSS LOAD CAPACITY WHEN USED AS A WEIGHT CARRYING HITCH: 3500 LBS. TRAILER WEIGHT & 300 LBS. TONGUE WEIGHT.*******DO NOT EXCEED VEHICLE MANUFACTURER'S RECOMMENDED TOWING CAPACITY.*******WARNING: ALL NON-TRAILER LOADS APPLIED TO THIS PRODUCT MUST BE SUPPORTED BY AUXILIARY STABILIZING STRAPS.****** FAILURE TO PROPERLY SUPPORT NON-TRAILER LOADS WILL VOID PRODUCT WARRANTY****

Parts List			
ITEM	QTY	PART NUMBER	DESCRIPTION
1	2	1/2-13	HANDLE NUT
2	2	1/2-13 x 1 3/4	HEX BOLT
3	2	1/2"	CONICAL TOOTHED WASHER
4	2	CM-SP12	.250 x 1.00 x 2.00" SQUARE HOLE SPACER
5	2	M10 - 1.50 x 45 SEM SCREW	SEM SCREW

**HITCH WEIGHT: 45 LBS.****INSTALL TIME**PROFESSIONAL: **30** MINUTESNOVICE (DIY): **60** MINUTES**INSTALL NOTES:**

- DRILLING ON SOME MODELS
- LOWER EXHAUST
- REMOVE CARBON CANISTER

NOTES:***SOME VEHICLES MAY NOT BE EQUIPPED WITH A CARBON CANISTER.******DRILLING MAY BE REQUIRED ON SOME MODELS.****INSTALLATION STEPS**

- 1) Remove the tie downs if present and return to owner.
- 2) Detach the rubber isolator from exhaust hanger bracket. Disconnect the electrical connectors from the carbon canister. Disconnect the hose by pinching the release button on the collar and pulling the hose off.
- 3) Lower the carbon canister by removing the two bolts located on the spare tire well along with two nuts near the center of the canister. **Canister can not be completely removed!**
- 4) Remove the inboard E.A. bolts from the frame end caps and discard bolts.
- 5) Position hitch on vehicle and attach to inboard side of E.A. units with M10 bolts provided. Insert a support block and handle nut through each frame access slot and fasten hitch mounting arms to vehicle frame using a 1/2" hex bolts and conical washers. (Drill mounting holes if needed.)
- 6) Torque all M10 fasteners to 45 LB/FT . Torque all 1/2" fasteners to 110 LB/FT.
- 7) Reattach rubber isolator to exhaust hanger bracket. Pass canister hose through access hole in hitch mounting plate and reconnect hose. Slide canister back into position and reinstall hardware.

PERIODICALLY CHECK THIS RECEIVER HITCH TO ENSURE THAT ALL FASTENERS ARE TIGHT AND THAT ALL STRUCTURAL COMPONENTS ARE SOUND.