



11424 INSTALLATION INSTRUCTIONS



Safety glasses should be worn at all times while installing this product.

YEARS: 2017-CURRENT

MAKE: HYUNDAI

MODEL: ELANTRA

STYLE: SEDAN

WARNING: NEVER EXCEED YOUR VEHICLE MANUFACTURER'S RECOMMENDED TOWING CAPACITY

WEIGHT CARRYING:
TRAILER WEIGHT: 2,000 LBS.
TONGUE WEIGHT: 200 LBS.

PRO INSTALL TIME: 45 MIN.
NOVICE INSTALL TIME: 90 MIN.

IF YOU ARE HESITANT TO UNDERTAKE THIS TASK ON YOUR OWN, CONTACT AN AUTHORIZED CURT INSTALLER FOR ADDITIONAL ASSISTANCE.



INSTALLATION REQUIRES:

 SCREW DRIVER	 10mm 15mm 17mm 9/16" SOCKET	 6" SOCKET EXTENSION
 RATCHET	 TORQUE WRENCH	 MASKING TAPE
 DIE GRINDER	 TAPE MEASURE	

INSTALLATION TIPS:

- BEFORE YOU BEGIN INSTALLATION, READ ALL INSTRUCTIONS THOROUGHLY.
- TO EASE INSTALLATION, 2 PEOPLE MAY BE REQUIRED.
- USING PROPER TOOLS WILL GREATLY IMPROVE THE QUALITY OF THE INSTALL AND REDUCE THE TIME REQUIRED.

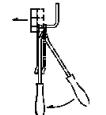
LEVEL OF DIFFICULTY: MODERATE

EASY	MODERATE	CHALLENGING
	NO DRILLING REQUIRED	
	LOWER EXHAUST	
	TRIM UNDERBODY PANEL	

VEHICLE PHOTO:



REPRESENTATIVE PHOTO

HITCH ILLUSTRATION:

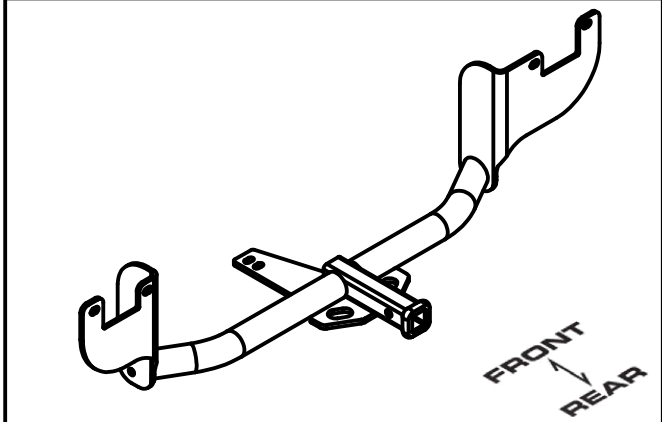

MAKE SURE YOUR HITCH MATCHES

INSTALLATION WALKTHROUGH:

Parts List			
ITEM	QTY	PART NUMBER	DESCRIPTION
1	1	CM-3805-UBR	3/8-16 x 1.938 x .875" U-BOLT
2	4	M10-1.25 x 35	HEX BOLT
3	4	7/16"	CONICAL TOOTHED WASHER
4	2	3/8 - 16	HEX NUT
5	2	3/8"	LOCK WASHER
6	2	5/16"	WASHER

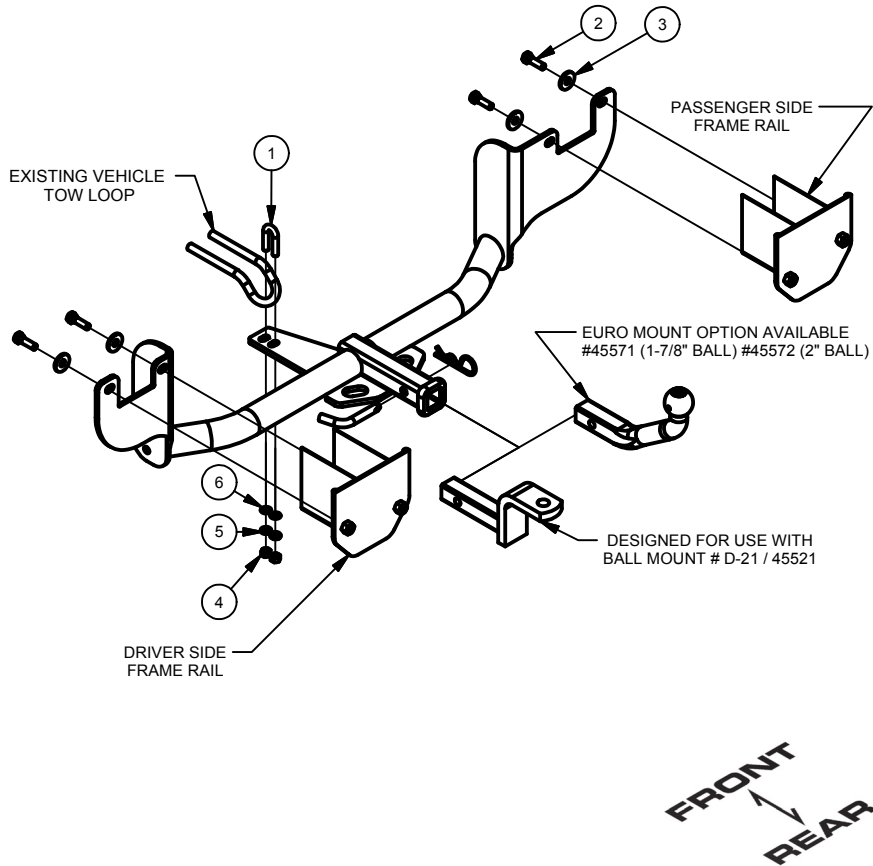

1. Lower exhaust by detaching (2) rubber isolators towards rear of vehicle.
(See RUBBER ISOLATOR REMOVAL DIAGRAM)



2. Temporarily remove driver side underbody panel by removing (3) clips using a flat head screwdriver and (4) nuts using a 10mm socket.



INSTALLATION WALKTHROUGH:

3. Remove (2) bolts using a 15mm socket on driver and passenger sides of vehicle on front facing section that attaches to the bumper beam. Place 3/8" u-bolt over vehicle tow loop.



4. Raise hitch into position and slide u-bolt through holes in hitch. Secure hitch to vehicle with M10 bolts and 7/16" conical toothed washers into locations where bolts were removed in step 3. Install 5/16" flat washers, 3/8" lock washers and 3/8" hex nuts onto u-bolt.

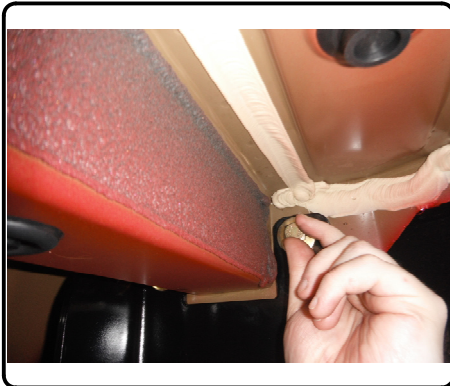

5. Torque M10 hardware to 86 lb-ft and 3/8" hardware to 26 lb-ft.



6. Mark cut location of underbody panel. (See UNDERBODY PANEL TRIM DIAGRAM) Cut out marked location using cutoff wheel.

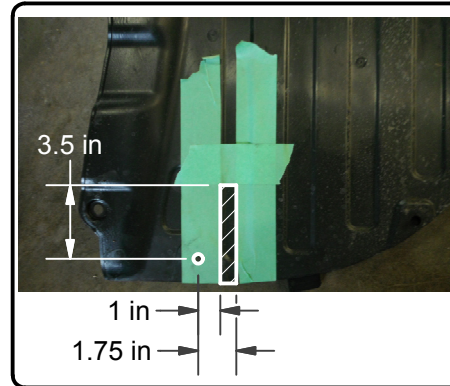

INSTALLATION WALKTHROUGH:

7. Reinstall underbody panel in reverse order of step 2.
Raise exhaust into position and reattach exhaust isolators.



TOWING SAFETY INFORMATION

Gross Trailer Weight / GTW

The Gross Trailer Weight is the weight of the trailer & cargo. Measure this by putting the fully loaded trailer on a vehicle scale.

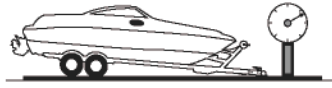

Tongue Weight / TW

The downward force that is exerted on the hitch ball by the coupler. The tongue weight will vary depending on where the load is positioned in relationship to the trailer axle(s). To measure the tongue weight, use either a commercial scale or a bathroom scale with the coupler at towing height. When using a bathroom scale with heavier tongue weights, use the method shown and multiply the scale reading by 3.

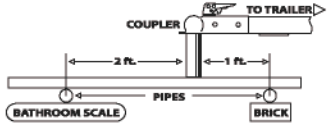

Weight Carrying / WC

The total weight of both the trailer and the cargo inside. Never exceed the weight capacity of your trailer hitch.

Weight Distribution / WD

Used to balance the weight of the cargo between the front and rear wheels throughout the trailer, allowing for better steering, braking, and level riding.



Sway Control

A device used to reduce the lateral movements of the trailer that are caused by the wind. This works in conjunction with a weight distribution hitch. Do not use this on a class 1 or 2 hitch, or with surge brakes.

How Much Can You Safely Tow?

TONGUE WEIGHT lbs	1000	2000	3000	4000	5000	6000	7000	8000	10,000	12,000
Tongue weight should be about 10 to 15 percent of the gross trailer weight.										
CLASS 1										
CLASS 2										
CLASS 3										
CLASS 4										
CLASS 5										
Camper	11'	12'	13'	14'	15'	16'				
lbs	1100	1200	1300	1400	1500	1600				
Vacation	14'	16'	18'	20'	22'	24'	26'	28'	30'	32'
lbs	2100	2400	2700	3000	3300	3600	3900	4200	4500	4800
Vacation	14'	16'	18'	20'	22'	24'	26'	28'	30'	32'
lbs	2800	3200	3600	4000	4400	4800	5200	5600	6000	6400
5th Wheel										

Refer to owner's manual for towing capabilities and limitations.

Ball Mount

The ball mount is placed inside the opening of the receiver hitch which is mounted to the vehicle. Make sure a hitch pin and clip is properly securing the ball mount to the receiver hitch before you begin towing.

- A: Rise. B: Drop. C: Hole Size. D: Length.

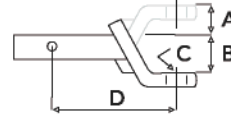

Trailer Ball

The connection from the hitch to the trailer. There are many factors that determine the correct hitch ball:

- Number one is the hitch ball's gross trailer weight rating.
- The mounting platform must be at least 3/8" thick.
- The hole diameter must not be more than 1/16" larger than the threaded shank.
- Every time you tow, check the nut and lock washer to make sure they are fastened securely.
- A: Ball Dia. B: Shank Dia. C: Shank Length. D: Shank Rise.

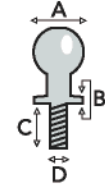

Coupler

The component that is placed over the trailer ball to connect the vehicle to the trailer. Be sure that the coupler size matches the size of the hitch ball and that the coupler handle is securely fastened. To determine what size hitch ball you need for your application you will need to know the size of coupler that is on the trailer. Be sure your coupler is properly adjusted to the ball you are using.

NOTE: For added security the use of safety devices such as Coupler Safety Pins and Locks is strongly recommended.

Safety Chains

Safety chains are a requirement and should be crossed under the tongue of the trailer so that the tongue will not drop to the road if it becomes separated from the hitch. Always leave enough slack so you can turn. Never allow the safety chains to drag on the ground and never attach the chains to the bumper.

Trailer Classification: Safety Chain Breaking Force - Minimum

- Class 1: 2,000 lbs. (8.9 kN)
- Class 2: 3,500 lbs. (15.6 kN)
- Class 3: 5,000 lbs. (22.2 kN)

The strength rating of each length of safety chain or its equivalent and its attachments shall be equal to or exceed in minimum breaking force the GVWR (Gross Vehicle Weight Rating) of the trailer.

Electrical

Trailer lights, Electric Brakes, Break-away systems - Every time you tow, be sure to check that all components are working properly.

Wiring identification by color:

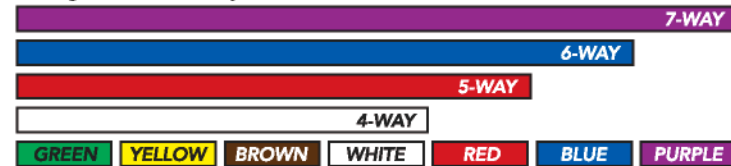

GREEN YELLOW BROWN WHITE RED BLUE PURPLE

11424

HYUNDAI ELANTRA

GROSS LOAD CAPACITY WHEN USED AS A WEIGHT CARRYING HITCH: 2,000 LBS. TRAILER WEIGHT & 200 LBS. TONGUE WEIGHT.
 WARNING: ALL NON-TRAILER LOADS APPLIED TO THIS PRODUCT MUST BE SUPPORTED BY 18050 STABILIZING STRAPS.



WARNING: ** FAILURE TO PROPERLY SUPPORT NON-TRAILER LOADS WILL VOID PRODUCT WARRANTY **

WARNING: * DO NOT EXCEED VEHICLE MANUFACTURER'S RECOMMENDED TOWING CAPACITY *****



Parts List			
ITEM	QTY	PART NUMBER	DESCRIPTION
1	1	CM-3805-UBR	3/8-16 x 1.938 x .875" U-BOLT
2	2	3/8 - 16	HEX NUT
3	2	3/8"	LOCK WASHER
4	2	5/16"	WASHER
5	4	M10-1.25 x 35	HEX BOLT
6	4	7/16"	CONICAL TOOTHED WASHER

TOOLS REQUIRED
FLAT HEAD SCREWDRIVER
10mm,15mm,17mm SOCKET
9/16" SOCKET
6" SOCKET EXTENSION
SOCKET WRENCH
TORQUE WRENCH
TAPE
CUTOFF WHEEL
TAPE MEASURE

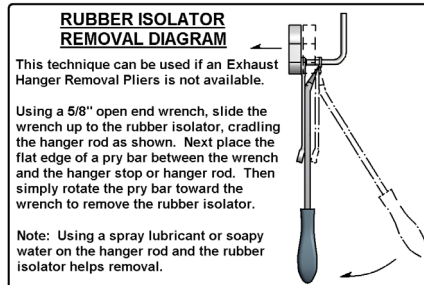
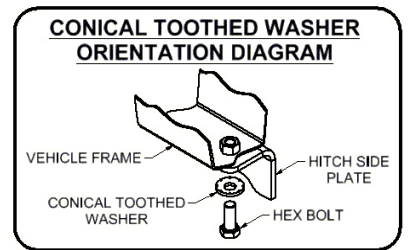
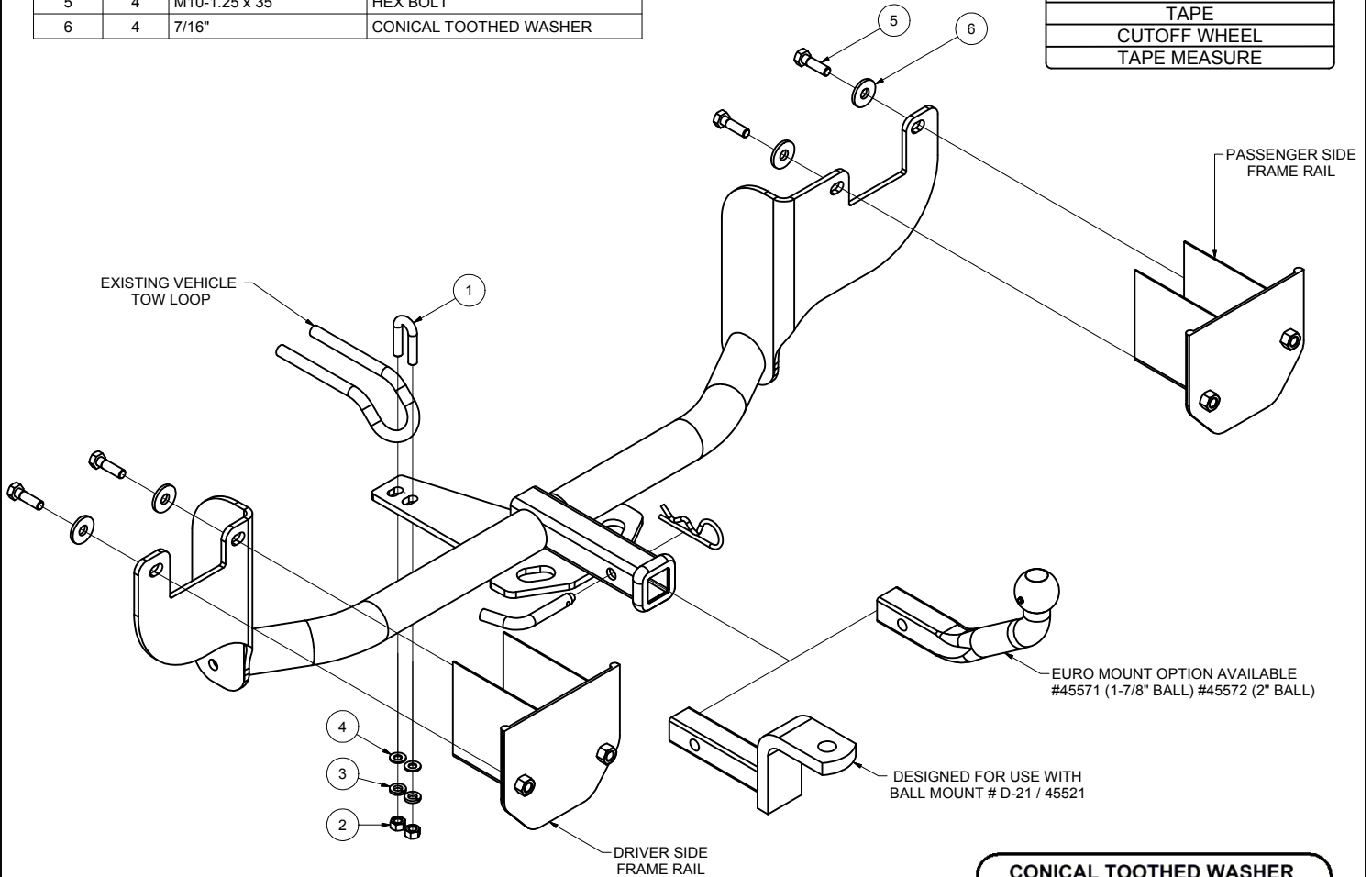

HITCH WEIGHT: 24 LBS.
 INSTALL TIME
 PROFESSIONAL: 45 MINUTES
 NOVICE (DIY): 90 MINUTES
 INSTALL NOTES:
 - NO DRILLING REQUIRED
 - LOWER EXHAUST
 - TRIM UNDERBODY PANEL

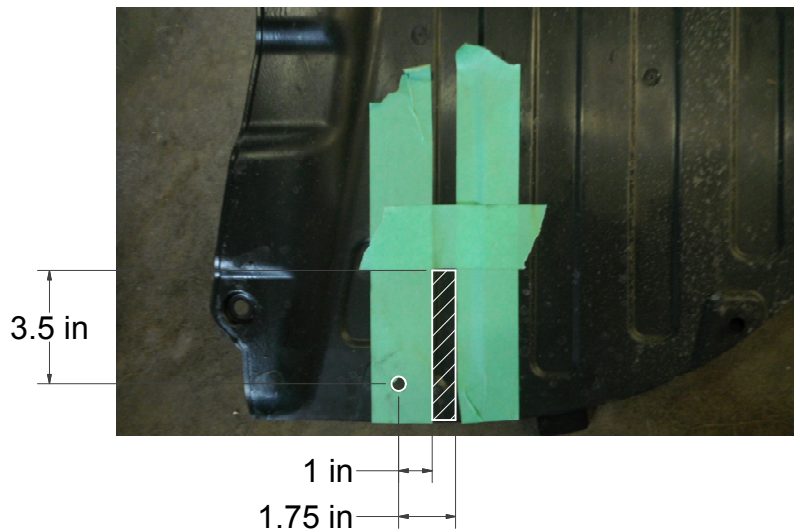

PERIODICALLY CHECK THIS RECEIVER HITCH TO ENSURE THAT ALL FASTENERS ARE TIGHT AND THAT ALL STRUCTURAL COMPONENTS ARE SOUND.

UNDERBODY PANEL TRIM DIAGRAM**INSTALLATION STEPS**

1. Lower exhaust by detaching (2) rubber isolators towards rear of vehicle. (See RUBBER ISOLATOR REMOVAL DIAGRAM)
2. Temporarily remove driver side underbody panel by removing (3) clips using a flat head screwdriver and (4) nuts using a 10mm socket.
3. Remove (2) bolts using a 15mm socket on driver and passenger sides of vehicle on front facing section that attaches to the bumper beam.
4. Place 3/8" u-bolt over vehicle tow loop.
5. Raise hitch into position and slide u-bolt through holes in hitch. Secure hitch to vehicle using supplied M10 bolts and 7/16" conical toothed washers. Fasten to vehicle into locations where bolts were removed in step 3. (See CONICAL TOOTHED WASHER ORIENTATION DIAGRAM)
6. Install 5/16" flat washers, 3/8" lock washers and 3/8" hex nuts onto u-bolt.
7. Torque M10 hardware to 48 lb-ft and 3/8" hardware to 26 lb-ft.
8. Mark cut location of underbody panel. (See UNDERBODY PANEL TRIM DIAGRAM)
9. Cut out marked location using cutoff wheel.
10. Reinstall underbody panel in reverse order of step 2.
11. Raise exhaust into position and reattach exhaust isolators.

PERIODICALLY CHECK THIS RECEIVER HITCH TO ENSURE THAT ALL FASTENERS ARE TIGHT AND THAT ALL STRUCTURAL COMPONENTS ARE SOUND.