

12362

1996-2007 CHRYSLER TOWN & COUNTRY, DODGE CARAVAN AND 96-04 PLYMOUTH VOYAGER (EXCEPT STOW & GO, AND SPORT MODELS)

GROSS LOAD CAPACITY WHEN USED AS A WEIGHT CARRYING HITCH: 3,500 LBS. TRAILER WEIGHT & 350 LBS. TONGUE WEIGHT.

DO NOT EXCEED VEHICLE MANUFACTURER'S RECOMMENDED TOWING CAPACITY.

WARNING: ALL NON-TRAILER LOADS APPLIED TO THIS PRODUCT MUST BE SUPPORTED BY AUXILIARY STABILIZING STRAPS.

** FAILURE TO PROPERLY SUPPORT NON-TRAILER LOADS WILL VOID PRODUCT WARRANTY**

		Parts List	
ITEM	QTY	PART NUMBER	DESCRIPTION
1	4	1/2-13 x 1 1/2	CARRIAGE BOLT
2	4	CM-SP12	.250 x 1.00 x 2.00" SQUARE HOLE SPACER
3	4	HFN 1213	HEX FLANGE NUT
4	2	1/2"	CONICAL TOOTHED WASHER
5	2	M12-1.75 x 35mm	HEX BOLT
6	2	1/2"	FISHWIRE TOOL

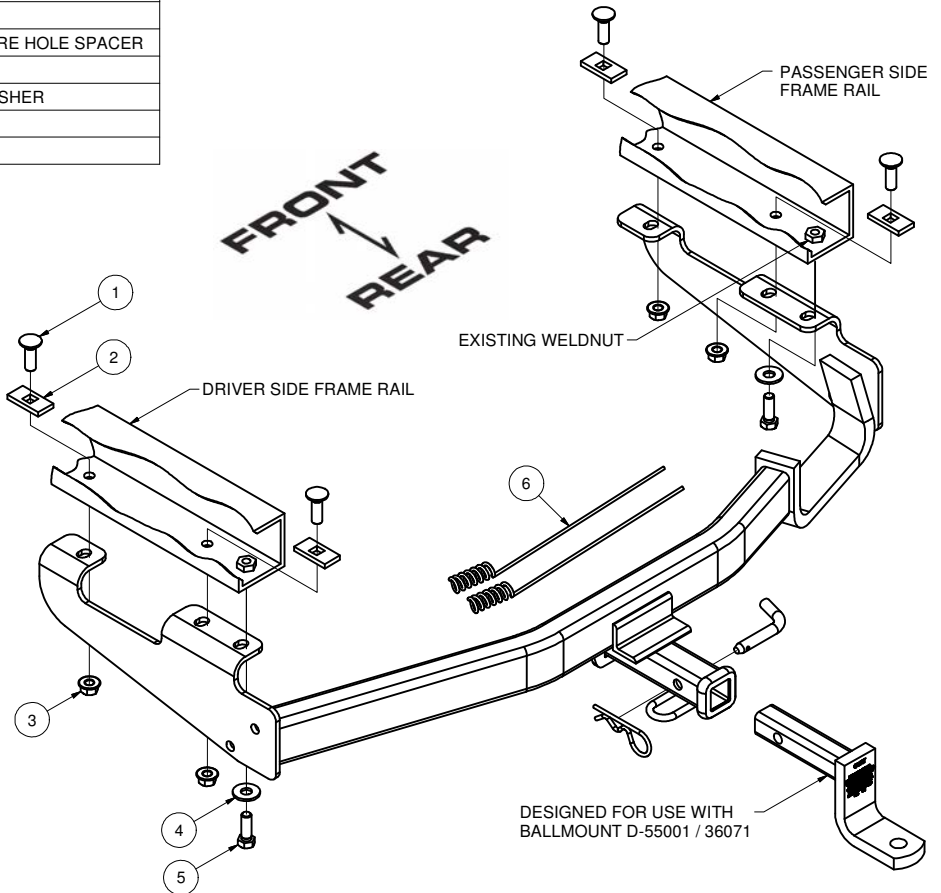
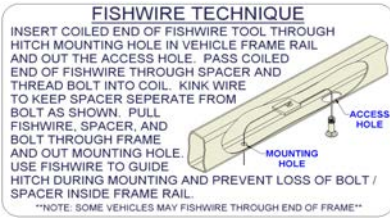

HITCH WEIGHT: 36 LBS.
 INSTALL TIME: 20 MINUTES
 INSTALL NOTES:
 - FISHWIRE HARDWARE
 - DRILLING MAY BE REQUIRED

INSTALLATION STEPS

- 1) Remove the rear most bumper bracket bolt from the underside of the frame on both sides. This bolt will be replaced with a new bolt later in the installation.
- 2) Locate the remaining mounting hole locations. There should be three per side. On some vehicles one or more of the mounting holes may need to be drilled. If drilling is required use the hitch as a template to mark the hole locations. Drill the holes using a 17/32" drill bit.
- 3) When all of the required mounting holes are present, use the provided fishwire tools to insert the carriage bolts and spacer through the frame access slot and out the proper mounting holes. If the access hole is not available, enlarge the square hole in the frame, or fishwire through the end of the frame rail behind the bumper.

NOTE: THERE IS A PLASTIC FLAP THE HARDWARE MUST PASS BY.

The rearmost carriage bolt should be installed in the available frame slot located between the bumper bracket bolts.

- 4) Raise the hitch into position and attach it to the frame using 1/2" hex flange nuts as shown.
- 5) Install the M12 hex bolt and 1/2" conical toothed washer through the hitch and into the bumper bracket.
- 6) Torque all 1/2" hardware to 110 ft-lbs. Torque all M12 hardware to 79 ft-lbs.

PERIODICALLY CHECK THIS RECEIVER HITCH TO ENSURE THAT ALL FASTENERS ARE TIGHT AND THAT ALL STRUCTURAL COMPONENTS ARE SOUND.



The **FIRST** Name in Towing Products™

Trailer Hitches