

12333

PONTIAC G6 & GT

GROSS LOAD CAPACITY WHEN USED AS A WEIGHT CARRYING HITCH: 3500 LBS. TRAILER WEIGHT & 350 LBS. TONGUE WEIGHT.

DO NOT EXCEED VEHICLE MANUFACTURER'S RECOMMENDED TOWING CAPACITY.

WARNING: ALL NON-TRAILER LOADS APPLIED TO THIS PRODUCT MUST BE SUPPORTED BY AUXILIARY STABILIZING STRAPS.

** FAILURE TO PROPERLY SUPPORT NON-TRAILER LOADS WILL VOID PRODUCT WARRANTY**

Parts List			
ITEM	QTY	PART NUMBER	DESCRIPTION
1	6	1/2-13 x 1 1/2	CARRIAGE BOLT
2	1	1/2"	FISHWIRE TOOL
3	6	CM-SP10	.250 x 1.00 x 2.50" SQUARE HOLE SPACER
4	6	HFN 1213	HEX FLANGE NUT
5	1	M6 - 1.00 X 25 HEX BOLT	HEX BOLT

FISHWIRE TECHNIQUE

INSERT COILED END OF FISHWIRE TOOL THROUGH HITCH MOUNTING HOLE IN VEHICLE FRAME RAIL AND OUT THE ACCESS HOLE. PASS COILED END OF FISHWIRE THROUGH SPACER AND THREAD BOLT INTO COIL. KINK WIRE TO KEEP SPACER SEPARATE FROM BOLT AS SHOWN. PULL FISHWIRE, SPACER, AND BOLT THROUGH FRAME AND OUT MOUNTING HOLE. USE FISHWIRE TO GUIDE HITCH DURING MOUNTING AND PREVENT LOSS OF BOLT / SPACER INSIDE FRAME RAIL.

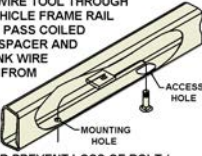

NOTE: SOME VEHICLES MAY FISHWIRE THROUGH END OF FRAME

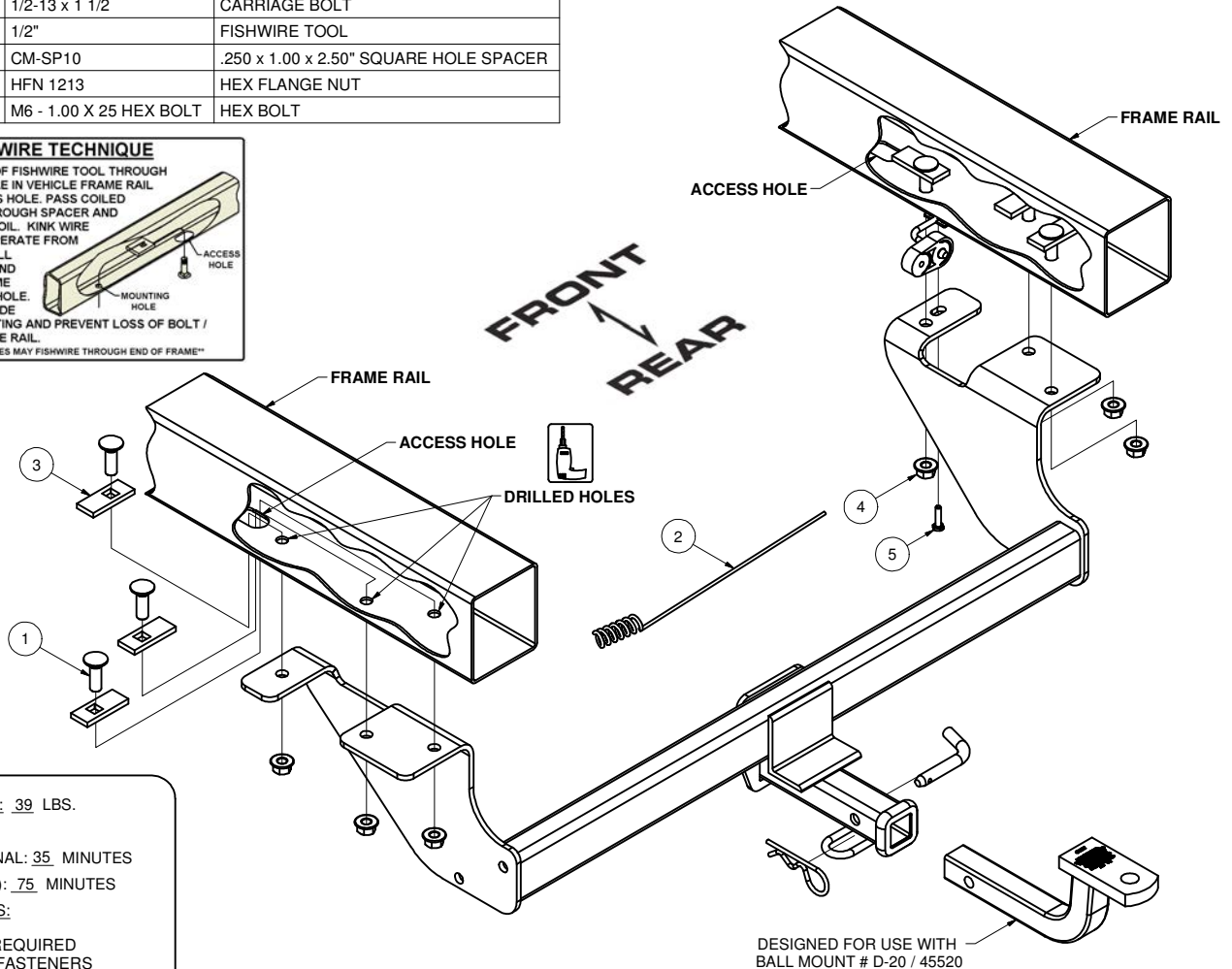

HITCH WEIGHT: .39 LBS.

INSTALL TIME

PROFESSIONAL: .35 MINUTES

NOVICE (DIY): .75 MINUTES

INSTALL NOTES:

- DRILLING REQUIRED
- FISHWIRE FASTENERS

INSTALLATION STEPS

- 1) Remove wire mounting strap from passengers side frame rail. (Reuse later)
- 2) Locate and mark the center of the vehicle.
- 3) Raise hitch into position, with hitch centered and square to vehicle mark and center punch (6) mounting holes. (Note: rear slot on passenger side will match up with existing strap mounting hole on vehicle.)
- 4) Drill (6) mounting holes using a 17/32" drill.
- 5) Fishwire 1/2" carriage bolts and spacers through existing access holes in frame and out drilled holes as shown. (See FISHWIRE TECHNIQUE) (Note: passenger side access hole is under strap.)
- 6) Raise hitch into position over carriage bolts and under wire mounting strap, secure with flange nuts as shown.
- 7) Reattach strap removed in step 1 using M6 bolt through slot in hitch.
- 8) Torque all 1/2" fasteners to 110 lb-ft and M6 bolt to 9 lb-ft.

PERIODICALLY CHECK THIS RECEIVER HITCH TO ENSURE THAT ALL FASTENERS ARE TIGHT AND THAT ALL STRUCTURAL COMPONENTS ARE SOUND.



The **FIRST** Name
in Towing Products™

Trailer Hitches