

12290

SUBARU OUTBACK WAGON AND LEGACY SEDAN

GROSS LOAD CAPACITY WHEN USED AS A WEIGHT CARRYING HITCH: 3,500 LBS. TRAILER WEIGHT & 350 LBS. TONGUE WEIGHT.

DO NOT EXCEED VEHICLE MANUFACTURER'S RECOMMENDED TOWING CAPACITY.

WARNING: ALL NON-TRAILER LOADS APPLIED TO THIS PRODUCT MUST BE SUPPORTED BY AUXILIARY STABILIZING STRAPS.

** FAILURE TO PROPERLY SUPPORT NON-TRAILER LOADS WILL VOID PRODUCT WARRANTY**

Parts List			
ITEM	QTY	PART NUMBER	DESCRIPTION
1	4	1/2-13 x 1 1/2	CARRIAGE BOLT
2	4	CM-SP6	.250 x 1.00 x 3.00" SQ. HOLE SPACER
3	4	HFN 1213	HEX FLANGE NUT
4	2	1_2 FISHWIRE	1/2" FISHWIRE

TOOLS REQUIRED
10 AND 19mm SOCKETS
8" EXTENSION
RATCHET
TORQUE WRENCH
DRILL AND 17/32" BIT
ROTARY TOOL / CARBIDE BIT
TIN SNIPS / FILE

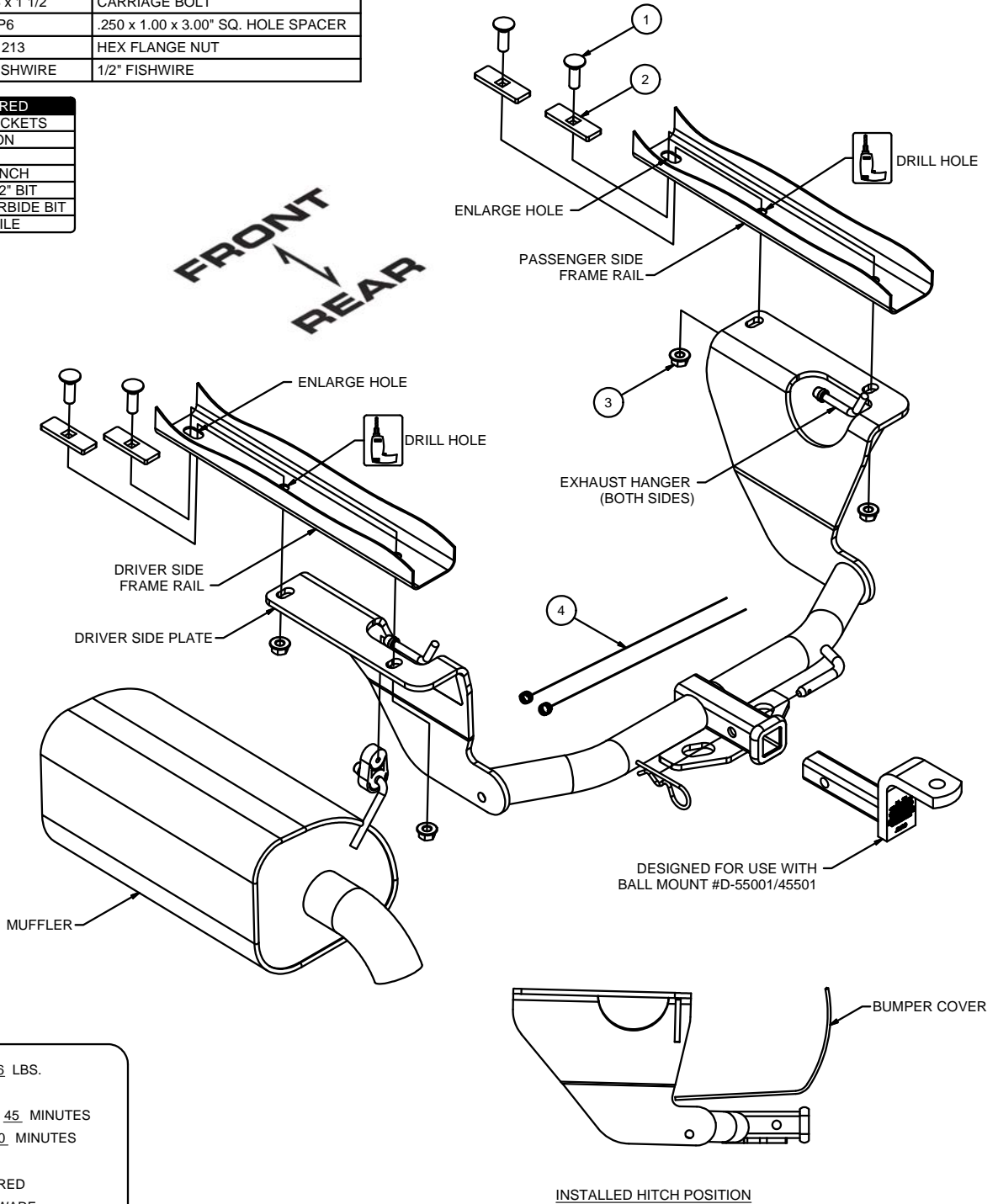

HITCH WEIGHT: .36 LBS.
 INSTALL TIME
 PROFESSIONAL: .45 MINUTES
 NOVICE (DIY): .90 MINUTES
 INSTALL NOTES:
 - DRILLING REQUIRED
 - FISHWIRE HARDWARE

PERIODICALLY CHECK THIS RECEIVER HITCH TO ENSURE THAT ALL FASTENERS ARE TIGHT AND THAT ALL STRUCTURAL COMPONENTS ARE SOUND.



The **FIRST** Name in Towing Products™

Trailer Hitches

FISHWIRE TECHNIQUE

INSERT COILED END OF FISHWIRE TOOL THROUGH HITCH MOUNTING HOLE IN VEHICLE FRAME RAIL AND OUT THE ACCESS HOLE. PASS COILED END OF FISHWIRE THROUGH SPACER AND THREAD BOLT INTO COIL. KINK WIRE TO KEEP SPACER SEPERATE FROM BOLT AS SHOWN. PULL FISHWIRE, SPACER, AND BOLT THROUGH FRAME AND OUT MOUNTING HOLE. USE FISHWIRE TO GUIDE HITCH DURING MOUNTING AND PREVENT LOSS OF BOLT / SPACER INSIDE FRAME RAIL.

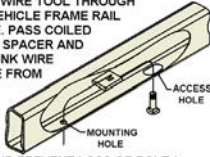

NOTE: SOME VEHICLES MAY FISHWIRE THROUGH END OF FRAME

RUBBER ISOLATOR REMOVAL DIAGRAM

This technique can be used if and Exhaust Hanger Removal Pliers is not available.

Using a 5/8" open end wrench, slide the wrench up to the rubber isolator, cradling the hanger rod as shown. Next place the flat edge of a pry bar between the wrench and the hanger stop or hanger rod. Then simply rotate the pry bar toward the wrench to remove the rubber isolator.

Note: Using a spray lubricant or soapy water on the hanger rod and the rubber isolator helps removal.

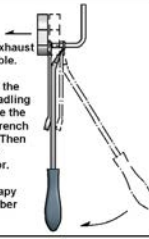

TRIM ALONG BEND LINE

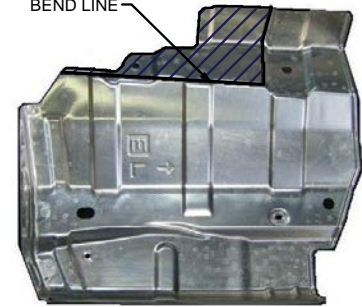

HEAT SHIELD TRIM DIAGRAM

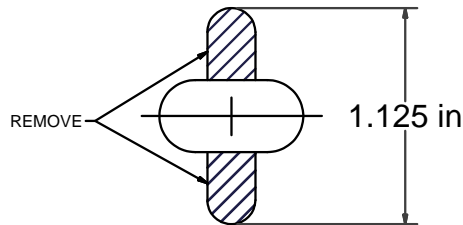

HOLE ENLARGEMENT DIAGRAM

INSTALLATION STEPS

1. Lower the exhaust by removing the (3) rearmost rubber exhaust isolators from the frame mounted hangers. Note: Support the exhaust during installation to prevent damage. (See Rubber Isolator Removal Diagram.)
2. Remove the muffler heat shield and trim to clear the mounting plate. (See Heat Shield Trim Diagram.)
3. Remove the (2) rubber plugs in each frame rail. Enlarge the forwardmost hole on each frame rail to allow the carriage bolt and spacer to be inserted into the frame rail. (See Hole Enlargement Diagram.)
4. Fishwire a carriage bolt and spacer into the rearmost hole in each frame rail as shown. (See Fishwire Hardware Technique.)
5. Raise the hitch into position, taking care not to push the fishwired hardware into the frame rails. Center the hitch on the vehicle and loosely secure the hitch to the vehicle with hex flange nuts as shown.
6. Mark and drill the forwardmost holes in the frame rail using the hitch as your template.
7. Fishwire a carriage bolt and spacer into each drilled hole and secure the hitch with a hex flange nuts as shown.
8. Torque all hardware to 110 ft-lbs.
9. Reinstall the heat shield, raise the exhaust and reinstall the rubber isolators.

PERIODICALLY CHECK THIS RECEIVER HITCH TO ENSURE THAT ALL FASTENERS ARE TIGHT AND THAT ALL STRUCTURAL COMPONENTS ARE SOUND.