

**12264****DODGE GRAND CARAVAN SXT / CHRYSLER TOWN AND COUNTRY TOURING ALL STO & GO MODELS / VOLKSWAGEN ROUTAN S, SE, SEL / RAM CARGO VAN****GROSS LOAD CAPACITY WHEN USED AS A WEIGHT CARRYING HITCH: 3,500 LBS. TRAILER WEIGHT & 350 LBS. TONGUE WEIGHT.**

\*\*\*DO NOT EXCEED VEHICLE MANUFACTURER'S RECOMMENDED TOWING CAPACITY.\*\*\*

**WARNING: ALL NON-TRAILER LOADS APPLIED TO THIS PRODUCT MUST BE SUPPORTED BY 18050 STABILIZING STRAPS.**

\*\* FAILURE TO PROPERLY SUPPORT NON-TRAILER LOADS WILL VOID PRODUCT WARRANTY\*\*

**TOOLS REQUIRED**

3/8" DRIVE RATCHET
18mm - 3/8 DRIVE SOCKET
15mm - 3/8" DRIVE SOCKET
13mm - 3/8" DRIVE SOCKET
TORQUE WRENCH
SCREW DRIVER / PUNCH
UTILITY KNIFE

**\*\*CAUTION\*\***

DO NOT PINCH OR CRUSH  
AC LINES (IF PRESENT)  
WHEN INSTALLING HITCH

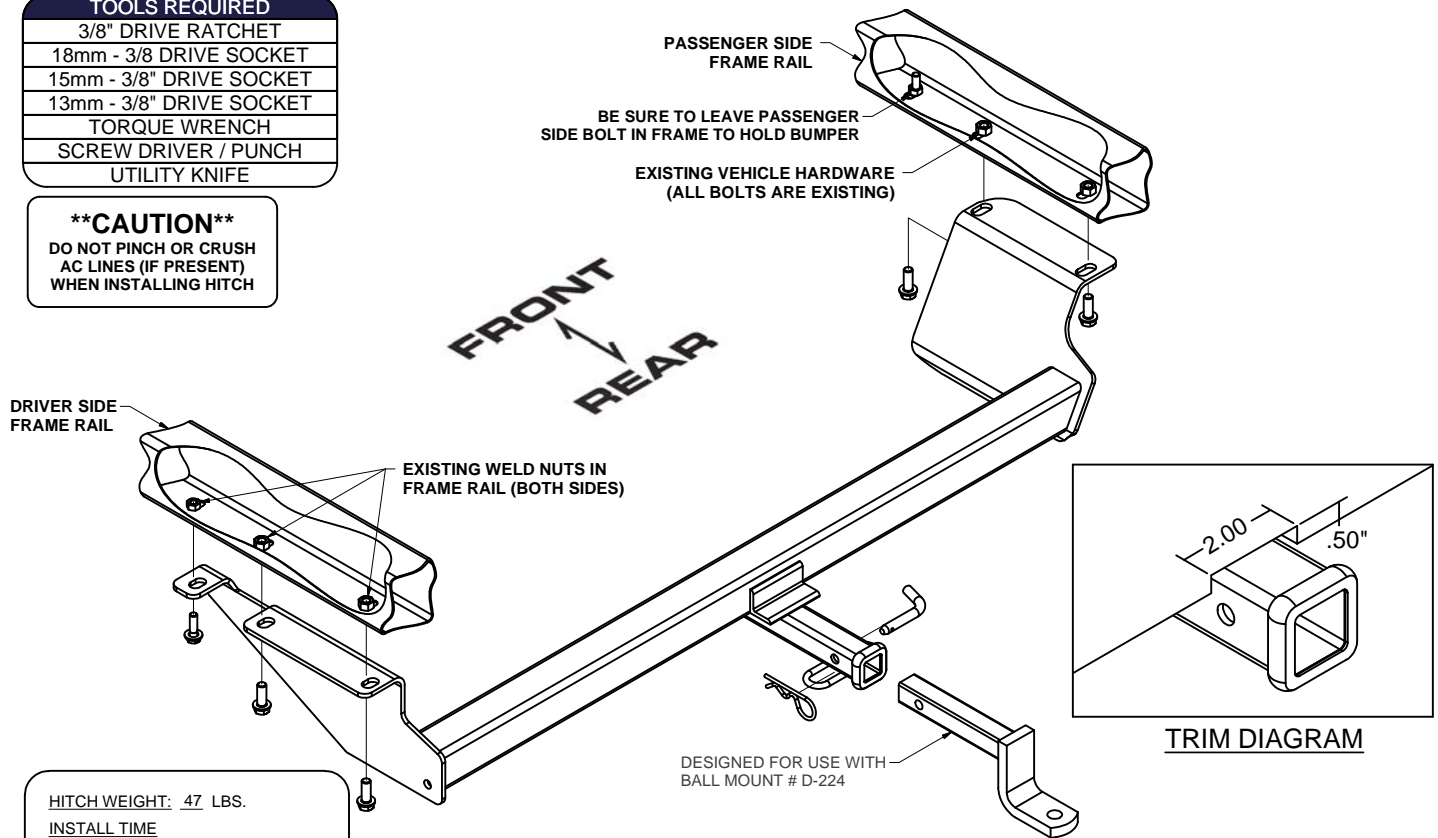

HITCH WEIGHT: 47 LBS.

**INSTALL TIME**

PROFESSIONAL: 10 MINUTES

NOVICE (DIY): 25 MINUTES

**INSTALL NOTES:**

- NO DRILLING REQUIRED
- USE EXISTING FASTENERS
- LOWER EXHAUST
- TRIMMING MAY BE REQUIRED

**\*\*\* USE EXISTING VEHICLE HARDWARE \*\*\*****\*\*\* BE SURE LEAVE BOLT ON PASSENGER SIDE TO HOLD BUMPER BEAM IN POSITION \*\*\*****INSTALLATION STEPS**

- 1) Locate and remove the (2) bolts using a 15mm socket and (3) bolts using a 18mm socket bolts as shown above. Leave (1) 12mm bolt on passenger side of vehicle frame toward the front of vehicle that holds the bumper bracket to vehicle frame. Remove the bolt(s) holding the exhaust and muffler hanger(s). This will allow exhaust to drop down out of the way for hitch installation.
- 2) Raise hitch into position against the bottom of vehicle frame and align holes in hitch frame brackets with the holes in vehicle frame. Be sure air conditioning (AC) lines are not pinched between hitch and frame rail (if AC lines are present). (Fascia trimming may be required on Town and Country van, refer to trim diagram).
- 3) Mount hitch using existing 10mm and 12mm bolts, may need a punch or screw driver to align holes.
- 4) Torque all 10mm fasteners to 48 lb-ft, and all 12mm fasteners to 83 lb-ft.
- 5) Raise the muffler and reinstall any other exhaust bolts removed earlier in Step 1.

**NOTE:** Rotating exhaust hanger bracket before tightening will add clearance between side bracket and exhaust.

PERIODICALLY CHECK THIS RECEIVER HITCH TO ENSURE THAT ALL FASTENERS  
ARE TIGHT AND THAT ALL STRUCTURAL COMPONENTS ARE SOUND.



The **FIRST** Name  
in Towing Products™

Trailer Hitches