

12157

97-04 BUICK PARK AVENUE

GROSS LOAD CAPACITY WHEN USED AS A WEIGHT CARRYING HITCH: 3,500 LBS. TRAILER WEIGHT &amp; 350 LBS. TONGUE WEIGHT.

**\*\*\*DO NOT EXCEED VEHICLE MANUFACTURER'S RECOMMENDED TOWING CAPACITY.\*\*\*****WARNING: ALL NON-TRAILER LOADS APPLIED TO THIS PRODUCT MUST BE SUPPORTED BY AUXILIARY STABILIZING STRAPS.****\*\* FAILURE TO PROPERLY SUPPORT NON-TRAILER LOADS WILL VOID PRODUCT WARRANTY\*\***

Parts List				
ITEM	QTY	PART NUMBER	DESCRIPTION	
1	2	CM-SP6	.250 x 1.00 x 3.00" SQUARE HOLE SPACER	
2	4	1/2"	NYLON WASHER	
3	1	M10 - 1.5 x 45mm	HEX BOLT	
4	2	CM-SP9	.250 x 1.25 x 2.50" SQUARE HOLE SPACER	
5	1	7/16"	CONICAL TOOTHED WASHER	
6	4	HFN 1213	HEX FLANGE NUT	
7	2	7/16 WASHER	WASHER	
8	2	7/16-14	HEX FLANGE NUT	
9	2	7/16-14 x 1 1/2	HEX BOLT	
10	6	CM-SP33	.250 x 1.50 x 2.00" SQUARE HOLE SPACER	
11	4	1/2 - 13 x 2"	CARRIAGE BOLT	
12	1	1/2"	FISHWIRE TOOL	

**FISHWIRE TECHNIQUE**

INSERT COILED END OF FISHWIRE TOOL THROUGH HITCH MOUNTING HOLE IN VEHICLE FRAME RAIL AND OUT THE ACCESS HOLE. PASS COILED END OF FISHWIRE THROUGH SPACER AND THREAD BOLT INTO COIL. KINK WIRE TO KEEP SPACER SEPARATE FROM BOLT AS SHOWN. PULL FISHWIRE, SPACER, AND BOLT THROUGH FRAME AND OUT MOUNTING HOLE. USE FISHWIRE TO GUIDE HITCH DURING MOUNTING AND PREVENT LOSS OF BOLT / SPACER INSIDE FRAME RAIL.

\*\*NOTE: SOME VEHICLES MAY FISHWIRE THROUGH END OF FRAME\*\*

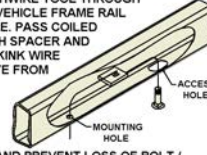
**RUBBER ISOLATOR REMOVAL DIAGRAM**

This technique can be used if an Exhaust Hanger Removal Pliers is not available.

Using a 5/8" open end wrench, slide the wrench up to the rubber isolator, cradling the hanger rod as shown. Next place the flat end of a pry bar between the wrench and the hanger stop or hanger rod. Then simply rotate the pry bar toward the wrench to remove the rubber isolator.

Note: Using a spray lubricant or soapy water on the hanger rod and the rubber isolator helps removal.

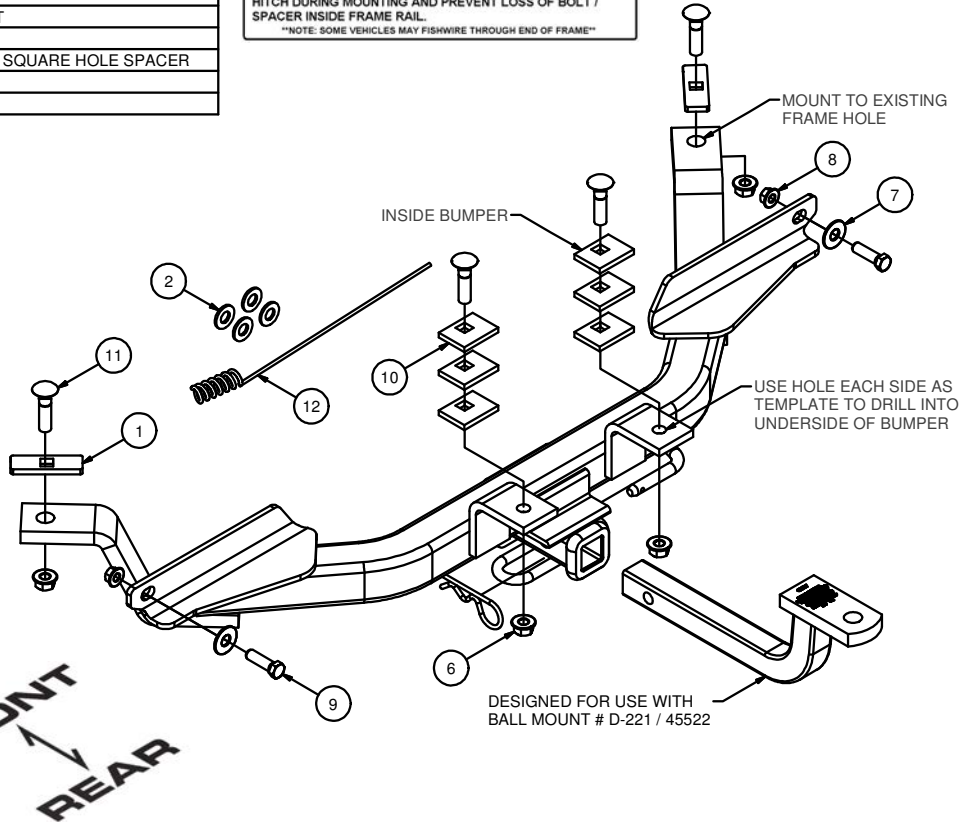
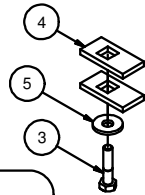
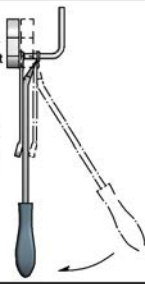

HITCH WEIGHT: .39 LBS.

**INSTALL TIME**

PROFESSIONAL: .45 MINUTES

NOVICE (DIY): .90 MINUTES

**INSTALL NOTES:**

- DRILLING REQUIRED
- LOWER EXHAUST

**INSTALLATION STEPS**

- 1) Support the exhaust and remove the bolt holding the exhaust hanger bracket to the bottom of the frame.
- 2) Loosen the top nuts and remove the bottom nut from the bolt strap which attaches the bumper to the vehicle frame. Bend the bottom of the "T" shaped strap out of the way or cut the tab if needed.
- 3) Raise hitch into position, lining up holes in hitch with existing holes in vehicle frame. Note: The existing attachment holes may need to be enlarged.
- 4) Using the hitch as a template, drill 1/2" holes in the bumper where the bolt strap was removed.
- 5) Place nylon washer (galvanic isolator) between the blocks which will be in contact with the bumper. Fishwire the 1/2" carriage bolts, spacer, and nylon washer through the end of the bumper and into the holes drilled in Step 4.
- 6) Fishwire the remaining fasteners to the proper locations. A reinforcement inside the frame may require the existing hole to be enlarged.
- 7) Add at least two spacers between the frame and the exhaust hanger bracket. Reinstall the exhaust hanger bracket with the M10 bolts provided.
- 8) Torque M10 fasteners to 45 LB-FT. Torque 1/2" fasteners to 110 LB-FT. Torque 7/16" fasteners to 70 LB-FT

**PERIODICALLY CHECK THIS RECEIVER HITCH TO ENSURE THAT ALL FASTENERS ARE TIGHT AND THAT ALL STRUCTURAL COMPONENTS ARE SOUND.**



The **FIRST** Name  
in Towing Products™

Trailer Hitches