



12115 INSTALLATION INSTRUCTIONS



Safety glasses should be worn at all times while installing this product.

YEARS:

MAKE: CHEVROLET, BUICK, CADILLAC

MODEL: IMPALA, MALIBU, REGAL, LACROSSE, XTS

STYLE: SEDAN

WARNING: NEVER EXCEED YOUR VEHICLE MANUFACTURER'S RECOMMENDED TOWING CAPACITY

WEIGHT CARRYING:
TRAILER WEIGHT: 3500 LBS.
TONGUE WEIGHT: 350 LBS.

PRO INSTALL TIME: 25 MIN.
NOVICE INSTALL TIME: 50 MIN.

IF YOU ARE HESITANT TO UNDERTAKE THIS TASK ON YOUR OWN, CONTACT AN AUTHORIZED CURT INSTALLER FOR ADDITIONAL ASSISTANCE.



INSTALLATION REQUIRES:

 RATCHET	 TORQUE WRENCH	 10mm 19mm SOCKET
 WIRE PIPE BRUSH	 AVIATION SHEARS	 DRILL BIT 1/2"
 POWER DRILL	 SAFETY GLASSES	

INSTALLATION TIPS:

- BEFORE YOU BEGIN INSTALLATION, READ ALL INSTRUCTIONS THOROUGHLY.
- TO EASE INSTALLATION, 2 PEOPLE MAY BE REQUIRED.
- USING PROPER TOOLS WILL GREATLY IMPROVE THE QUALITY OF THE INSTALL AND REDUCE THE TIME REQUIRED.

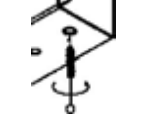
LEVEL OF DIFFICULTY: MODERATE

EASY	MODERATE	CHALLENGING
	-HOLE ENLARGEMENT REQUIRED ON SELECT MODELS	
	-USE EXISTING WELDNUTS	
	-TRIM REQUIRED ON SELECT MODELS	

VEHICLE PHOTO:



REPRESENTATIVE PHOTO

TRAILER HITCH ILLUSTRATION:

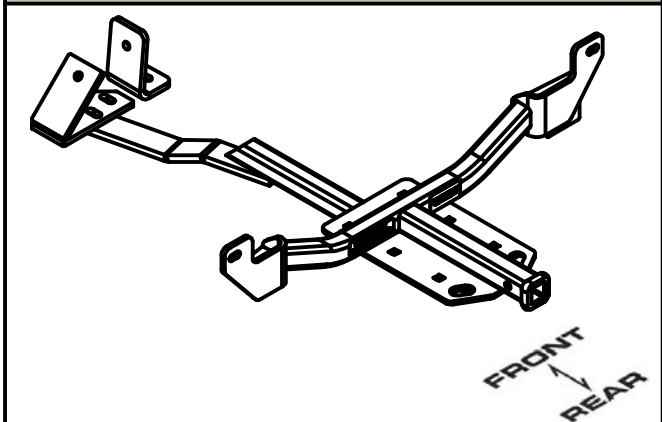

MAKE SURE YOUR HITCH MATCHES

PERIODICALLY CHECK THIS RECEIVER HITCH TO ENSURE ALL FASTENERS ARE TIGHT AND ALL STRUCTURAL COMPONENTS ARE SOUND
CURT Manufacturing LLC. warrants this product to be free of defects in material and/or workmanship at the time of retail purchase by the original purchaser. If the product is found to be defective, Curt Manufacturing LLC. may repair or replace the product at their option, when the product is returned, prepaid, with proof of purchase. Alteration to, misuse of, or improper installation of this product voids the warranty. Curt Manufacturing LLC.'s liability is limited to repair or replacement of products found to be defective, and specifically excludes liability for incidental or consequential loss or damage.

INSTALLATION WALKTHROUGH:

Parts List			
ITEM	QTY	PART NUMBER	DESCRIPTION
1	5	HFN 1213, GR8	HEX FLANGE NUT
2	4	1/2-13 x 1 1/2, GR8	CARRIAGE BOLT
3	2	1_2 - 13 x 1 1_2 HEX, GR8	HEX BOLT
4	2	M8 - 1.25 x 30 HEX BOLT	HEX HEAD BOLT
5	1	1/2-13	HANDLE NUT
6	2	1/2"	LOCK WASHER
7	2	3/8"	CONICAL TOOTHED WASHER
8	2	M8-1.25	HEX NUT
9	1	CM-SP38	1/2" WEDGE SPACER

WEDGE SPACER USED ON ALL APPLICATIONS BEFORE MID YEAR 2013 (FWD) MODELS

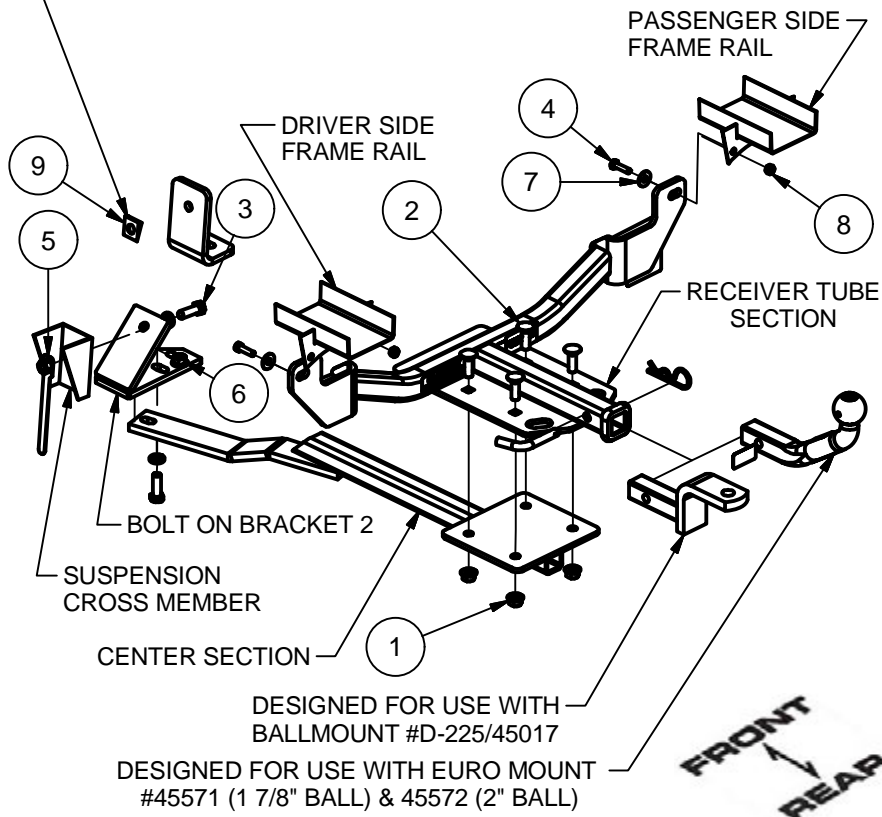

1. Remove (1) 8mm bolt from the exhaust hanger bracket on each side of the vehicle, and clean weldnut using a wire brush or spray lubricant. On Impala models only trim approximately a 1 1/4 inch deep notch from each side of the bottom bumper fascia (As shown).

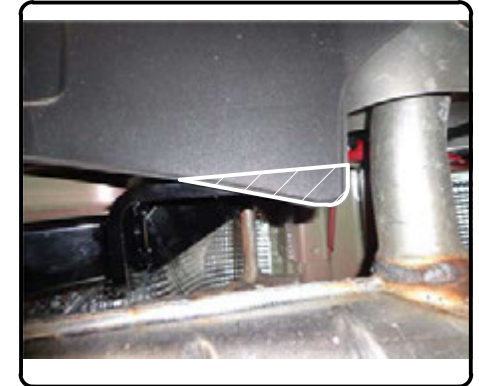
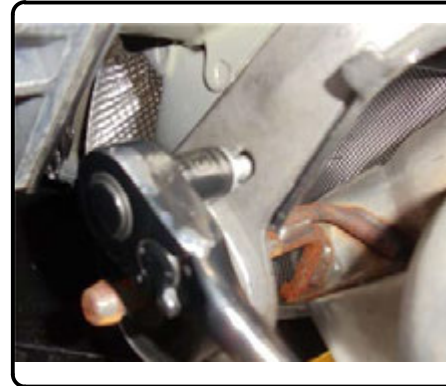

2. Raise receiver tube section of hitch into place and use the 8mm bolts and conical toothed washers provided to secure into place. Secure the 8mm nut to the back side of the frame bracket on each side to hold the exhaust bracket in place.

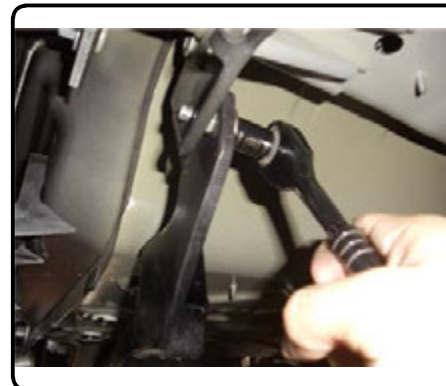

INSTALLATION WALKTHROUGH:

3. On Buick Lacrosse (AWD) and Cadillac XTS models enlarge the rearward hole in the suspension cross member to 1/2" (as shown).

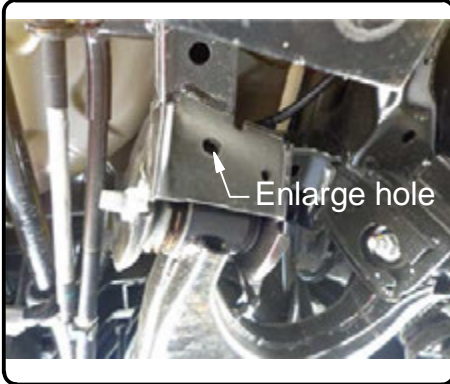

4. Assemble the bolt on bracket as shown by placing the handle nut in the suspension housing and securing with a 1/2" bolt and lock washer. (Shown below is the bolt on bracket (1) used on (FWD) vehicles built before mid year, 2013. The bolt on bracket (2) is used on all (AWD) and (FWD) models built 2013 mid year to present.)

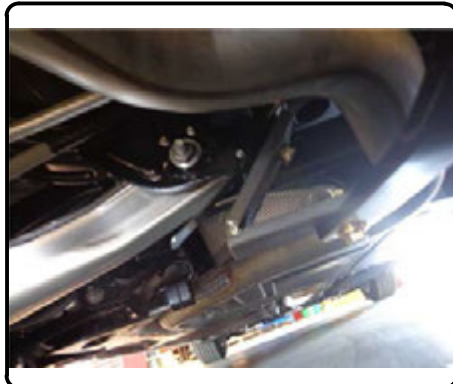

5. Raise the center section of the hitch into place and loosely secure the (5) 1/2" hardware components that hold it into place. Torque 1/2" bolt with handle nut to 75 lb-ft, all other 1/2" hardware to 110 lb-ft, and torque 8mm hardware to 23 lb-ft.



6. Installation is complete.



12115

CHEVROLET IMPALA AND MALIBU BUICK REGAL AND LACROSSE CADILLAC XTS

GROSS LOAD CAPACITY WHEN USED AS A WEIGHT CARRYING HITCH: 3500 LBS. TRAILER WEIGHT & 350 LBS. TONGUE WEIGHT.

DO NOT EXCEED VEHICLE MANUFACTURER'S RECOMMENDED TOWING CAPACITY.

WARNING: ALL NON-TRAILER LOADS APPLIED TO THIS PRODUCT MUST BE SUPPORTED BY 18050 STABILIZING STRAPS.

** FAILURE TO PROPERLY SUPPORT NON-TRAILER LOADS WILL VOID PRODUCT WARRANTY**

Parts List			
ITEM	QTY	PART NUMBER	DESCRIPTION
1	5	HFN 1213, GR8	HEX FLANGE NUT
2	4	1/2-13 x 1 1/2, GR8	CARRIAGE BOLT
3	2	1_2 - 13 x 1 1_2 HEX, GR8	HEX BOLT
4	2	M8 - 1.25 x 30 HEX BOLT	HEX HEAD BOLT
5	1	1/2-13	HANDLE NUT
6	2	1/2"	LOCK WASHER
7	2	3/8"	CONICAL TOOTHED WASHER
8	2	M8-1.25	HEX NUT
9	1	CM-SP38	1/2" WEDGE SPACER

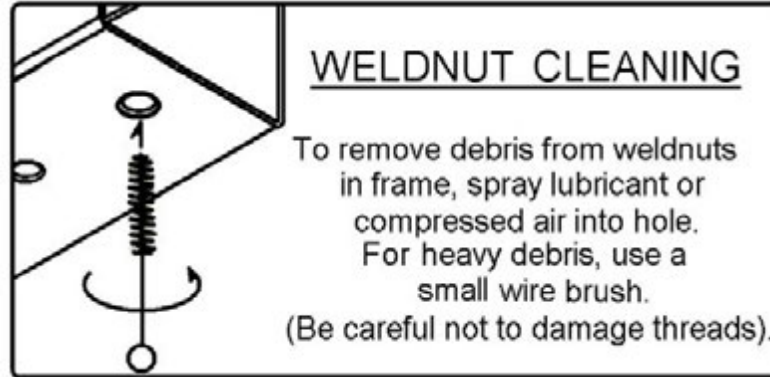

TOOLS REQUIRED
RATCHET
TORQUE WRENCH
10mm & 19 mm SOCKET
WIRE PIPE BRUSH
AVIATION SHEARS
1/2" DRILL BIT
POWER DRILL

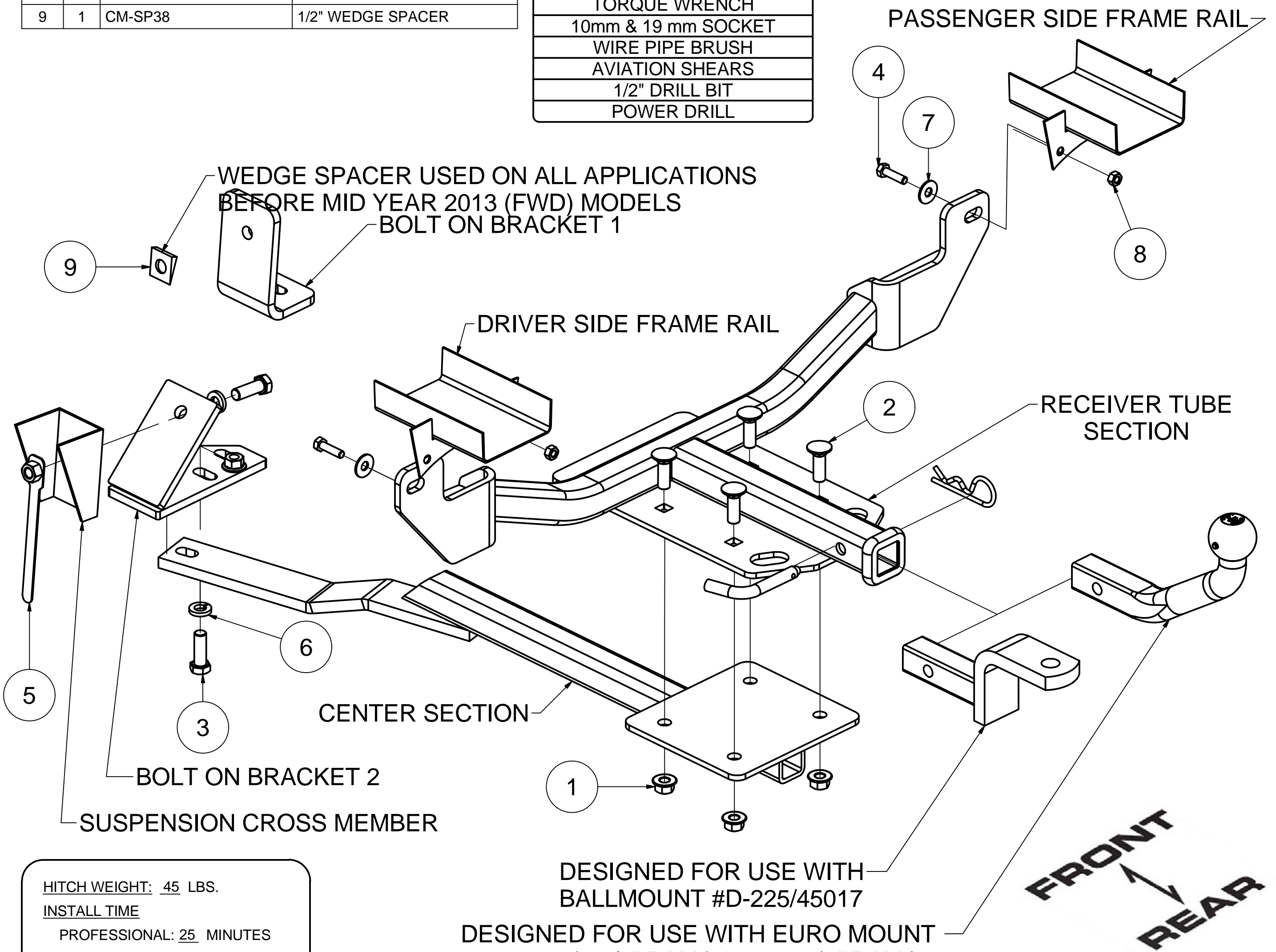
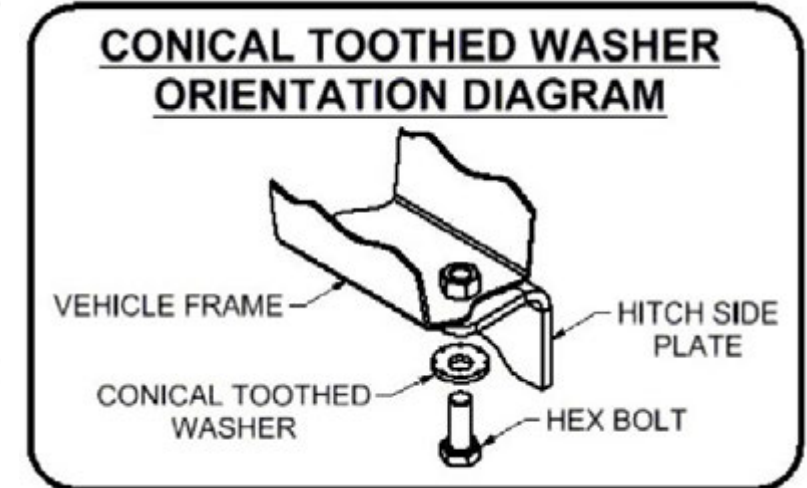

DESIGNED FOR USE WITH BALLMOUNT #D-225/45017
DESIGNED FOR USE WITH EURO MOUNT #45571 (1 7/8" BALL) & 45572 (2" BALL)

HITCH WEIGHT: 45 LBS.

INSTALL TIME

PROFESSIONAL: 25 MINUTES

NOVICE (DIY): 50 MINUTES

INSTALL NOTES:

- HOLE ENLARGEMENT REQUIRED ON SELECT MODELS
- USE EXISTING WELDNUTS
- TRIM REQUIRED ON SELECT MODELS

PERIODICALLY CHECK THIS RECEIVER HITCH TO ENSURE THAT ALL FASTENERS ARE TIGHT AND THAT ALL STRUCTURAL COMPONENTS ARE SOUND.

Curt Manufacturing LLC., warrants this product to be free of defects in material and/or workmanship at the time of retail purchase by the original purchaser. If the product is found to be defective, Curt Manufacturing LLC., may repair or replace the product, at their option, when the product is returned, prepaid, with proof of purchase. Alteration to, misuse of, or improper installation of this product voids the warranty. Curt Manufacturing LLC.'s liability is limited to repair or replacement of products found to be defective, and specifically excludes liability for incidental or consequential loss or damage.

12115

**CHEVROLET IMPALA AND MALIBU
BUICK REGAL AND LACROSSE
CADILLAC XTS**



TRIM DIAGRAM

REAR OF VEHICLE ← → FRONT OF VEHICLE
ENLARGE THIS HOLE
(STEP 3) IF REQUIRED

INSTALLATION STEPS

1. Remove (1) 8mm bolt from the exhaust hanger bracket on each side of the vehicle, and clean weldnut using a wire brush or spray lubricant. On Impala models only trim approximately a 1 1/4 inch deep notch from each side of the bumper fascia (As shown).
2. Raise receiver tube section of hitch into place and use the 8mm bolts and conical toothed washers provided to secure into place. Secure the 8mm nut to the back side of the frame bracket on each side to hold the exhaust bracket in place.
3. On Buick Lacrosse (AWD) and Cadillac XTS models enlarge the hole in the suspension cross member to 1/2" (as shown).
4. Assemble the bolt on bracket as shown by placing the handle nut in the suspension housing and securing with a 1/2" bolt and lock washer. (Shown above is the bolt on bracket (1) used on (FWD) vehicles built before mid year, 2013. The bolt on bracket (2) is used on all (AWD) and (FWD) models built 2013 mid year to present.)
5. Raise the center section of the hitch into place and secure the (5) 1/2" hardware components that hold it into place. Torque 1/2" bolt with handle nut to 75 lb-ft, all other 1/2" hardware to 110 lb-ft, and torque 8mm hardware to 23 lb-ft.

PERIODICALLY CHECK THIS RECEIVER HITCH TO ENSURE THAT ALL FASTENERS
ARE TIGHT AND THAT ALL STRUCTURAL COMPONENTS ARE SOUND.

Curt Manufacturing LLC., warrants this product to be free of defects in material and/or workmanship at the time of retail purchase by the original purchaser. If the product is found to be defective, Curt Manufacturing LLC., may repair or replace the product, at their option, when the product is returned, prepaid, with proof of purchase. Alteration to, misuse of, or improper installation of this product voids the warranty. Curt Manufacturing LLC.'s liability is limited to repair or replacement of products found to be defective, and specifically excludes liability for incidental or consequential loss or damage.