

12086

HYUNDAI GENESIS

GROSS LOAD CAPACITY WHEN USED AS A WEIGHT CARRYING HITCH: 3,500 LBS. TRAILER WEIGHT & 350 LBS. TONGUE WEIGHT.
*****DO NOT EXCEED VEHICLE MANUFACTURER'S RECOMMENDED TOWING CAPACITY.*****

Parts List			
ITEM	QTY	PART NUMBER	DESCRIPTION
1	4	1/2-13 x 1 3/4	CARRIAGE BOLT
2	4	CM-SP6	.250 x 1.00 x 3.00" SQUARE HOLE SPACER
3	4	HFN 1213	HEX FLANGE NUT
4	2	1_2 FISHWIRE	1/2" FISHWIRE

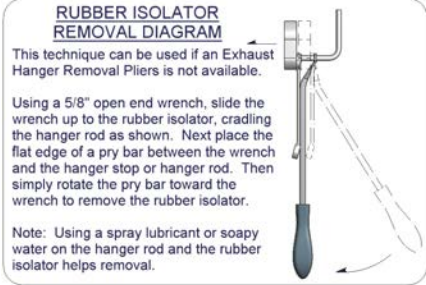
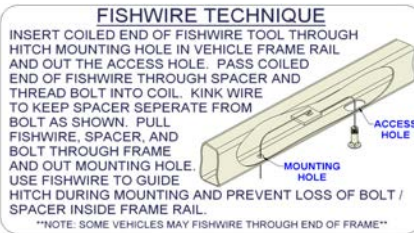

TOOLS REQUIRED

DRILL W/ 17/32" DRILL BIT
RATCHET
10mm, 19mm SOCKET
3/4" SOCKET
TORQUE WRENCH
AVIATOR SHEARS
PENCIL / MARKER

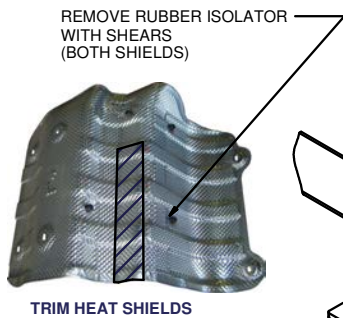
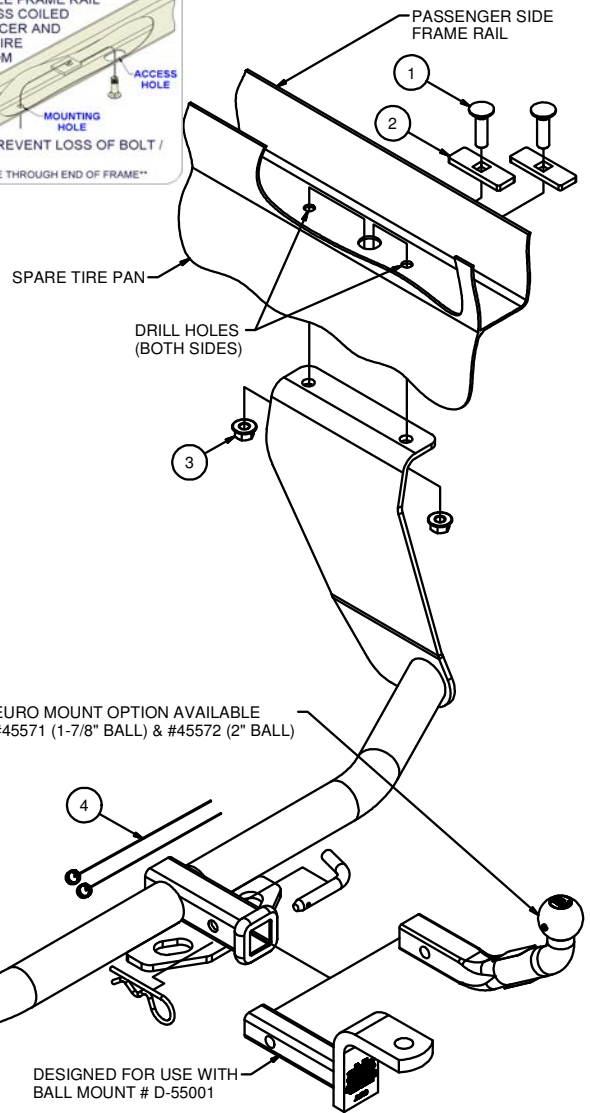

HITCH WEIGHT: 31 LBS.
 INSTALL TIME: 90 MINUTES
 INSTALL NOTES:
 - LOWER EXHAUST
 - DRILLING REQUIRED
 - FISHWIRE HARDWARE
 - TRIM HEAT SHIELD
 - 2 PERSON INSTALL RECOMENDED

INSTALLATION STEPS

- 1) On 2012 models remove (2) nuts with a 19mm socket in front of mufflers each side. Remove (4) rear rubber exhaust isolators, and gently lower exhaust. Remove heat shields by removing (6) screws with a 10mm socket, both sides.
 - 2) Raise hitch into position, center and square to frame rails and vehicle, just after the frame angles downward. Mark and drill (4) holes with 17/32" drill bit for 1/2" fasteners.
 - 3) Lower hitch and fishwire bolts and spacers into position as shown in the diagrams above.
 - 4) Raise hitch back into position and install supplied hex flange nuts. Torque all 1/2" fasteners to 110 lb-ft.
 - 5) Modify heat shields as shown above and reinstall with original fasteners. Raise exhaust and reinstall (4) rubber exhaust isolators removed in step (1). On 2012 models bolt exhaust back together with original fasteners.
- PERIODICALLY CHECK THIS RECEIVER HITCH TO ENSURE THAT ALL FASTENERS ARE TIGHT AND THAT ALL STRUCTURAL COMPONENTS ARE SOUND.**



The **FIRST** Name in Towing Products™

Trailer Hitches